

**PHILIPS**

Data handbook



Electronic  
components  
and materials

# Electron tubes

Part 3 February 1983

**Klystrons**

**Travelling-wave tubes**

**Microwave diodes**



# ELECTRON TUBES

PART 3 - FEBRUARY 1983

## KLYSTRONS, TWTs, MICROWAVE DIODES

GENERAL SECTION A

HIGH-POWER KLYSTRONS B

REFLEX KLYSTRONS C

TRAVELLING-WAVE TUBES D

DIODES E

T-R SWITCHES F

INDEX G



# RATING SYSTEM

(in accordance with IEC Publication 134)

## ABSOLUTE MAXIMUM RATING SYSTEM

Absolute maximum ratings are limiting values of operating and environmental conditions applicable to any electronic device of a specified type as defined by its published data, which should not be exceeded under the worst probable conditions.

These values are chosen by the device manufacturer to provide acceptable serviceability of the device, taking no responsibility for equipment variations, environmental variations, and the effects of changes in operating conditions due to variations in the characteristics of the device under consideration and of all other electronic devices in the equipment.

The equipment manufacturer should design so that, initially and throughout life, no absolute maximum value for the intended service is exceeded with any device under the worst probable operating conditions with respect to supply variation, equipment component variation, equipment control adjustment, load variations, signal variation, environmental conditions, and variations in characteristics of the device under consideration and of all other electronic devices in the equipment.

## CLASSIFICATION

The devices are classified as follows:

**N = New type.** Recommended for new equipment design. Data is derived from development samples, made available for evaluation. It does not necessarily imply that the device will go into regular production.

**D = Design type.** Recommended for equipment design; production quantities available at date of publication.

**C = Current type.** No longer recommended for equipment design; available for equipment production and for use in existing equipment.

**M = Maintenance type.** No longer recommended for equipment production; available for maintenance of existing equipment.

**O = Obsolescent type.** Available until present stocks are exhausted.

Obsolescent types of which all stocks are exhausted are called **obsolete**; any data still published on these types is for reference purposes only.

The status of all types is given in a type survey at the end of the general section, together with data in condensed form.

## DATA HANDBOOK SYSTEM

Our Data Handbook System is a comprehensive source of information on electronic components, sub-assemblies and materials; it is made up of four series of handbooks each comprising several parts.

ELECTRON TUBES	BLUE
SEMICONDUCTORS	RED
INTEGRATED CIRCUITS	PURPLE
COMPONENTS AND MATERIALS	GREEN

The several parts contain all pertinent data available at the time of publication, and each is revised and reissued periodically.

Where ratings or specifications differ from those published in the preceding edition they are pointed out by arrows. Where application information is given it is advisory and does not form part of the product specification.

If you need confirmation that the published data about any of our products are the latest available, please contact our representative. He is at your service and will be glad to answer your inquiries.

This information is furnished for guidance, and with no guarantee as to its accuracy or completeness; its publication conveys no licence under any patent or other right, nor does the publisher assume liability for any consequence of its use; specifications and availability of goods mentioned in it are subject to change without notice; it is not to be reproduced in any way, in whole or in part without the written consent of the publisher.

## ELECTRON TUBES (BLUE SERIES)

The blue series of data handbooks is comprised of the following parts:

- T1** Tubes for r.f. heating
- T2** Transmitting tubes for communications
- T3** Klystrons, travelling-wave tubes, microwave diodes
- ET3** Special Quality tubes, miscellaneous devices (will not be reprinted)
- T4** Magnetrons
- T5** Cathode-ray tubes  
Instrument tubes, monitor and display tubes, C.R. tubes for special applications
- T6** Geiger-Müller tubes
- T7** Gas-filled tubes  
Segment indicator tubes, indicator tubes, dry reed contact units, thyratrons, industrial rectifying tubes, ignitrons, high-voltage rectifying tubes, associated accessories
- T8** Picture tubes and components  
Colour TV picture tubes, black and white TV picture tubes, colour monitor tubes for data graphic display, monochrome monitor tubes for data graphic display, components for colour television, components for black and white television and monochrome data graphic display
- T9** Photo and electron multipliers  
Photomultiplier tubes, phototubes, single channel electron multipliers, channel electron multiplier plates
- T10** Camera tubes and accessories, image intensifiers
- T11** Microwave components and assemblies

## SEMICONDUCTORS (RED SERIES)

The red series of data handbooks is comprised of the following parts:

- S1 Diodes**  
Small-signal germanium diodes, small-signal silicon diodes, voltage regulator diodes (< 1,5 W), voltage reference diodes, tuner diodes, rectifier diodes
- S2 Power diodes, thyristors, triacs**  
Rectifier diodes, voltage regulator diodes (> 1,5 W), rectifier stacks, thyristors, triacs
- S3 Small-signal transistors**
- S4 Low-frequency power transistors and hybrid IC modules**
- S5 Field-effect transistors**
- S6 R.F. power transistors and modules**
- S7 Microminiature semiconductors for hybrid circuits**
- S8 Devices for optoelectronics**  
Photosensitive diodes and transistors, light-emitting diodes, displays, photocouplers, infrared sensitive devices, photocorductive devices.
- S9 Taken into handbook T11 of the blue series**
- S10 Wideband transistors and wideband hybrid IC modules**

## INTEGRATED CIRCUITS (PURPLE SERIES)

The purple series of data handbooks is comprised of the following parts:

- IC1** Bipolar ICs for radio and audio equipment
- IC2** Bipolar ICs for video equipment
- IC3** ICs for digital systems in radio, audio and video equipment
- IC4** Digital integrated circuits  
LOC MOS HE4000B family
- IC5** Digital integrated circuits – ECL  
ECL10 000 (GX family), ECL100 000 (HX family), dedicated designs
- IC6\*** Professional analogue integrated circuits
- IC7** Signetics bipolar memories
- IC8** Signetics analogue circuits
- IC9** Signetics TTL logic

\* This handbook will be available later this year.



## COMPONENTS AND MATERIALS (GREEN SERIES)

The green series of data handbooks is comprised of the following parts:

- C1 Assemblies for industrial use**  
PLC modules, PC20 modules, HNIL FZ/30 series, NORbits 60-, 61-, 90-series, input devices, hybrid ICs, peripheral devices
- C2 Television tuners, video modulators, surface acoustic wave filters**
- C3 Loudspeakers**
- C4 Ferroxcube potcores, square cores and cross cores**
- C5 Ferroxcube for power, audio/video and accelerators**
- C6 Electric motors and accessories**  
Permanent magnet synchronous motors, stepping motors, direct current motors
- C7 Variable capacitors**
- C8 Variable mains transformers**
- C9 Piezoelectric quartz devices**  
Quartz crystal units, temperature compensated crystal oscillators, compact integrated oscillators, quartz crystal cuts for temperature measurements
- C10 Connectors**
- C11 Non-linear resistors**  
Voltage dependent resistors (VDR), light dependent resistors (LDR), negative temperature coefficient thermistors (NTC), positive temperature coefficient thermistors (PTC)
- C12 Variable resistors and test switches**
- C13 Fixed resistors**
- C14 Electrolytic and solid capacitors**
- C15 Film capacitors, ceramic capacitors**
- C16 Piezoelectric ceramics, permanent magnet materials**



GENERAL SECTION

A



**List of symbols**

**Definitions**

**Waveguides**

**Flanges**



TUBES FOR MICROWAVE EQUIPMENT  
LIST OF SYMBOLS

**1. Symbols denoting electrodes and electrode connections**

Anode	a
Accelerator electrode	acc
Collector electrode	coll
Anode of a detection diode	d
Filament or heater	f
Filament or heater tap	f <sub>c</sub>
Grid	g
Tube pin which must not be connected externally	i.c.
Cathode	k
Reflector electrode	refl
Resonator	res
Helical electrode	x

**2. Symbols denoting voltages**

**Remarks**

- a. In the case of indirectly heated tubes the voltages on the various electrodes are with respect to the cathode; in the case of directly heated, d.c. fed tubes, with respect to the negative side of the filament; and in the case of directly heated, a.c. fed tubes, with respect to the electrical centre of the filament, unless otherwise stated.
- b. The symbols quoted below represent the average values of the voltages concerned, unless otherwise stated.

Anode voltage	$V_a$
Anode voltage in cut-off or in cold condition	$V_{ao}$
Accelerator voltage	$V_{acc}$
Supply voltage of tube electrodes	$V_b$
Collector voltage	$V_{coll}$
Anode voltage of a detection diode	$V_d$

# LIST OF SYMBOLS

## 2. Symbols denoting voltages (continued)

Filament or heater voltage	$V_f$
Filament or heater starting voltage	$V_{fo}$
Grid voltage	$V_g$
A.C. input voltage	$V_i$
Ignition voltage (voltage necessary for breakdown to the electrode concerned)	$V_{ign}$
Inverse voltage	$V_{inv}$
Voltage between cathode and heater	$V_{kf}$
A.C. output voltage	$V_o$
Peak value of a voltage	$V_p$
Reflector voltage	$V_{refl}$
Resonator voltage	$V_{res}$
Voltage on helical electrode	$V_x$

## 3. Symbols denoting currents

### Remarks

- The positive electrical current is directed opposite to the direction of the electron current.
- The symbols quoted below represent the average values of the currents concerned, unless otherwise stated.

Anode current	$I_a$
Accelerator current	$I_{acc}$
Collector current	$I_{coll}$
Current of a detection diode	$I_d$
Filament or heater current	$I_f$
Filament or heater starting current	$I_{fo}$
Peak filament or heater starting current	$I_{fp}, I_{fsurge}$
Grid current	$I_g$
Cathode current	$I_k$
Peak value of a current	$I_p$
Resonator current	$I_{res}$
Current to helical electrode	$I_x$

**4. Symbols denoting powers**

Anode dissipation	$W_a$
Collector dissipation	$W_{coll}$
A.C. driving power	$W_{dr}$
Grid dissipation	$W_g$
Input power	$W_i$
D.C. anode supply power	$W_{ia}$
Peak input power	$W_{ip}$
Output power	$W_o$
Peak output power	$W_{op}$
Resonator dissipation	$W_{res}$

**5. Symbols denoting capacitances**

Measured on the cold tubes.

Capacitance between anode and all other elements except control grid	$C_a$
Capacitance between anode and grid (all other elements being earthed)	$C_{ag}$
Capacitance between anode and cathode (all other elements being earthed)	$C_{ak}$
Capacitance between anode of a detection diode and all other elements of diode	$C_d$
Capacitance between a grid and all other elements except anode	$C_g$
Capacitance between a grid and cathode (all other elements being earthed)	$C_{gk}$

**6. Symbols denoting resistances**

External a.c. resistance in anode lead or matching resistance	$R_a$
Filament or heater resistance in cold condition	$R_{fo}$
External resistance in a grid lead	$R_g$
Internal resistance of a tube	$R_i$
External resistance in a cathode lead	$R_k$
External resistance between cathode and heater	$R_{kf}$

# LIST OF SYMBOLS

## 7. Symbols denoting various quantities

Bandwidth	B
Noise factor	F
Frequency	f
Pulse repetition rate	$f_{imp}$
Pushing figure of a magnetron	$\frac{\Delta f}{\Delta I_a}$
Frequency temperature coefficient	$\frac{\Delta f}{\Delta t}$
Pulling figure of a magnetron	$\Delta f_p$
Power gain	G
Magnetic field strength	H
Height above sea level	h
Pressure drop of cooling air or cooling water	$P_i$
Required air flow or water flow for cooling	q
Transconductance	S
Temperature of anode or anode block	$t_a$
Ambient temperature	$t_{amb}$
Averaging time of current or voltage	$T_{av}$
Inlet temperature of cooling air or cooling water	$t_i$
Pulse duration	$T_{imp}$
Outlet temperature of cooling air or cooling water	$t_o$
Time of rise of voltage	$T_{rv}$
Cathode preheating time, also called waiting time; the minimum period of time during which the heater or filament voltage should be applied before the application of electrode voltages	$T_w$
Rate of rise of voltage	$\frac{dV_a}{dT}, \frac{\Delta V}{\Delta T_{rv}}$
Voltage standing-wave ratio	VSWR
Reflection coefficient	$\sigma$
Duty factor	$\delta$
Efficiency	$\eta$
Wavelength	$\lambda$
Amplification factor	$\mu$



## TUBES FOR MICROWAVE EQUIPMENT

### DEFINITIONS

- B** Bandwidth
- $\Delta f/\Delta t$  The temperature coefficient  $\Delta f/\Delta t$  is the change of frequency with temperature.
- $f_{imp}$  Pulse repetition rate.
- $\Delta f_p$  The pulling figure  $\Delta f_p$  is the difference between the maximum and minimum frequencies, reached when the phase angle of the load with a VSWR of 1,5 is varied from  $0^\circ$  to  $360^\circ$ .
- H** Magnetic field strength.
- $T_{imp}$  The pulse duration  $T_{imp}$  is defined as the time interval between the two points on the current pulse at which the current is 50% of the smooth peak current (see Fig. 1).

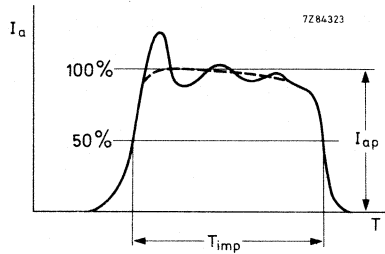

Fig. 1 Current pulse.

The smooth peak is the maximum value of a smooth curve through the average of the fluctuation over the top portion of the pulse.

- $T_{rv}$  The time of rise of voltage  $T_{rv}$  is defined as the time interval between points of 20 and 85 per cent of the smooth peak value measured on the leading edge of the voltage pulse.
- $t_a$  Temperature of anode or anode block.
- VSWR The voltage standing-wave ratio in a waveguide is the ratio of the amplitude in the electrical field at a voltage maximum to that at an adjacent minimum.

# DEFINITIONS

$dV_a/dT$   
or  
 $\Delta V_a/\Delta T_{rv}$  Unless otherwise stated the rate of rise of voltage  $dV_a/dT$  is defined by the steepest tangent to the leading edge of the voltage pulse above 80% of the smooth peak value (see Fig. 2).

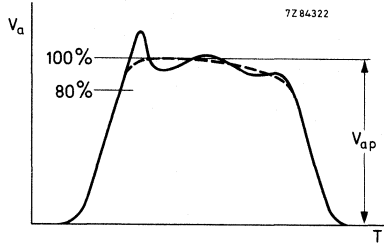

Fig. 2 Voltage pulse.

$V_{fo}$  Heater voltage before switching on of anode voltage. When the magnetron oscillates, not all electrons reach the anode. These off-phase electrons are driven back to the cathode. This back bombardment contributes to the heating power of the cathode. In order to maintain the total power to the cathode at the rated value, it is therefore necessary in some cases to reduce or even to switch off the heater voltage after application of high voltage.

$\delta$  The duty factor  $\delta$  is the ratio of the pulse duration to the time between corresponding points of two successive pulses.

$$\delta = T_{imp} (s) \times f_{imp} (Hz).$$

# RECTANGULAR WAVEGUIDE DATA AND DESIGNATIONS

FREQUENCY RANGE TE <sub>10</sub> mode 153-IEC* GHz	WAVEGUIDE DESIGNATION				WAVEGUIDE Inner cross-section 153-IEC*			WAVEGUIDE Outer cross-section 153-IEC*			ATTENUATION in dB/m for copper waveguide 153-IEC*		Theoretical C. W. power rating** lowest to highest frequency MW				
	153-IEC*	BRITISH STAND.	REIMA brass	JAN RC-7U alum.	BAND PREFIX	Width mm	Height mm	Tolerance on width and height ±	Width mm	Height mm	Tolerance on width and height ±	Frequency GHz		Theoretical value	Maximum value		
1.14 — 1.73	R 14	WG 6	WR650	69	103	L	165.10	82.55	0.33	169.16	86.61	0.20	1.36	0.00522	0.007	12.0	-17.0
1.45 — 2.20	R 18	WG 7	WR510	—	—	D	129.54	64.77	0.26	133.60	68.83	0.20	1.74	0.00749	0.010	7.5	-11.0
1.72 — 2.61	R 22	WG 8	WR430	104	105	—	109.22	54.61	0.22	113.28	58.67	0.20	2.06	0.00970	0.013	5.2	-7.5
2.17 — 3.30	R 26	WG 9A	WR340	112	113	—	86.36	43.18	0.17	90.42	47.24	0.17	2.61	0.0138	0.018	3.4	-4.8
2.60 — 3.95	R 32	WG 10	WR284	48	75	S	72.14	34.04	0.14	76.20	38.10	0.14	3.12	0.0189	0.025	2.2	-3.2
3.22 — 4.90	R 40	WG 11A	WR229	—	—	A	56.17	29.083	0.12	61.42	32.33	0.12	3.87	0.0249	0.032	1.6	-2.2
3.94 — 5.99	R 48	WG 12	WR187	49	95	G	47.55	22.149	0.095	50.80	25.40	0.095	4.73	0.0355	0.046	0.94	-1.32
4.64 — 7.05	R 58	WG 13	WR159	—	—	C	40.39	20.193	0.081	43.64	23.44	0.081	5.57	0.0431	0.056	0.79	-1.0
5.38 — 8.17	R 70	WG 14	WR137	50	106	J	34.85	15.799	0.070	38.10	19.05	0.070	6.46	0.0576	0.075	0.56	-0.71
6.57 — 9.99	R 84	WG 15	WR112	51	68	H	28.499	12.624	0.057	31.75	15.88	0.057	7.89	0.0794	0.103	0.35	-0.46
7.00 — 11.00	—	—	WR102	—	320	T	25.90	12.95	0.125	29.16	16.21	0.125	—	—	—	0.33	-0.43
8.2 — 12.5	R 100	WG 16	WR 90	52	67	X	22.850	10.160	0.046	25.40	12.70	0.05	9.84	0.110	0.143	0.20	-0.29
9.84 — 15.0	R 120	WG 17	WR 75	—	—	M	19.050	9.525	0.038	21.59	12.06	0.05	11.8	0.133	—	0.17	-0.23
11.9 — 18.0	R 140	WG 18	WR 62	91	—	P	15.799	7.699	0.031	17.83	9.93	0.05	14.2	0.176	—	0.12	-0.16
14.5 — 22.0	R 180	WG 19	WR 51	—	—	—	12.954	6.477	0.026	14.99	8.51	0.05	17.4	0.238	—	0.080	-0.107
17.6 — 26.7	R 220	WG 20	WR 42	53	121	—	10.668	4.318	0.021	12.70	6.35	0.05	21.1	0.370	—	0.043	-0.058
21.7 — 33.0	R 260	WG 21	WR 34	—	—	—	8.636	4.318	0.020	10.67	6.35	0.05	26.1	0.435	—	0.034	-0.048
26.4 — 40.0	R 320	WG 22	WR 28	—	—	—	7.112	3.556	0.020	9.14	5.59	0.05	31.6	0.583	—	0.022	-0.031
32.9 — 50.1	R 400	WG 23	WR 22	—	—	—	5.690	2.845	0.020	7.72	4.88	0.05	39.5	0.815	—	0.014	-0.020
39.2 — 59.6	R 500	WG 24	WR 19	—	—	—	4.775	2.388	0.020	6.81	4.42	0.05	47.1	1.060	—	0.011	-0.015
49.8 — 75.8	R 620	WG 25	WR 15	—	—	—	3.759	1.880	0.020	5.79	3.91	0.05	59.9	1.52	—	0.0063	-0.0090
60.5 — 91.9	R 740	WG 26	WR 12	—	—	—	3.099	1.549	0.020	5.13	3.58	0.05	72.6	2.03	—	0.0042	-0.0061
73.8 — 112.0	R 900	WG 27	WR 10	—	—	—	2.540	1.270	0.020	4.57	3.30	0.05	88.6	2.74	—	0.0030	-0.0041
92.2 — 140.0	R 1200	WG 28	WR 8	—	—	—	2.032	1.016	0.020	4.06	3.05	0.05	111.0	3.82	—	0.0018	-0.0026
114.0 — 173.0	R 1400	WG 29	WR 7	—	—	—	1.651	0.826	—	—	—	—	136.3	5.21	—	0.0012	-0.0017

\* IEC Recommendations are obtainable from :  
 Central Office of the International Electrotechnical Commission  
 1, rue de Varembe  
 GENEVA, Switzerland

\*\* based on breakdown of air of 15,000 volts per cm  
 (safety factor of approx. 2 at sea level)



# FLANGE DESIGNATIONS

## FLANGE DESIGNATIONS











FOR WAVEGUIDE 153 - IEC*	FLANGE DESIGNATION					
	PLAIN FLANGE			CHOKE FLANGE		
	154 - IEC	JAN UG /U		154 - IEC	JAN UG /U	
		Brass	Aluminium		Brass	Aluminium
R 14	PDR 14	417A	418A			
R 18	PDR 18					
R 22	PDR 22	435A	437A			
R 26	PDR 26	553	554			
R 32	UER 32 PDR 32 PAR 32 UAR 32	53	584	CAR 32	54A	585A
R 40	UER 40 PDR 40					
R 48	PAR 48 PDR 48 UAR 48 UER 48	149A	407	CAR 48	148C	406B
R 58	PAR 58 PDR 58 UAR 58 UER 58			CAR 58		
R 70	PAR 70 PDR 70 UAR 70 UER 70	344	441	CAR 70	343B	440B
R 84	PBR 84 PDR 84 UBR 84 UER 84	51	138	CBR 84	52B	137B
R 100	PBR 100 PDR 100 UBR 100 UER 100	39	135	CBR 100	40B	136B
R 120						
R 140	PBR 140 UBR 140	419		CBR 140	541A	
R 180						
R 220	PBR 220 UBR 220 PCR 220	595	597	CBR 220	596A	598A
R 260	PCR 260					
R 320	PBR 320 PCR 320 UBR 320	599		CBR 320	600A	
R 400	PCR 400	383				
R 500	PCR 500 PAR 500					
R 620	PCR 620 PFR 620	385				
R 740	PCR 740 PFR 740	387				
R 900	PCR 900 PFR 900					
R 1200	PCR1200 PFR 1200					

# FLANGE DESIGNATIONS

## IEC

Waveguide flanges covered by IEC recommendation shall be indicated by a reference number comprising the following information:

- the number of the present IEC publication.
- the letters "IEC".
- a dash.
- a letter relating to the basic construction of the flange
  - P = pressurable
  - C = choke, pressurizable
  - U = unpressurizable
- a letter for the type according to the drawing. Flanges with the same letter and of the same waveguide size can be mated.
- the letter and number of the waveguide for which the flange is designed.

UNPRESSURABLE		PRESSURABLE		CHOKE			
 Type E	14	 Type A	 Type D	14	 Type A	 Type A	
	32			32			
	70			70			
	84 100			84 100			
 Type B	120	 Type C	 Type B	220	 Type B		
	320			320		320	
				500		500	500
						620	
		 Type F		1200			

\* IEC Recommendations are obtainable from :  
 Central Office of the  
 International Electrotechnical Commission  
 1, rue de Varembe  
 GENEVA, Switzerland

SURVEY

High-power klystrons

|||||

type	status	cooling	$W_o$ kW	gain dB	frequency range MHz
YK1000	M	W/FA	11	30	400 to 620
YK1001	M	FA	11	30	470 to 860
YK1002	M	W/FA/V	11	30	470 to 860
YK1004	M	W/FA	11	30	610 to 790
YK1005	M	FA	11	40	470 to 860
YK1110	C	W	6000	30	2998 ± 5
YK1151	M	FA	25	40	470 to 860
YK1190	D	V/W	45		470 to 610
YK1191	D	V/W	45		590 to 720
YK1192	D	V/W	45		710 to 860
YK1195	D	V/W	58		470 to 610
YK1196	D	V/W	58		590 to 720
YK1197	D	V/W	58		710 to 860
YK1198	D	V/W	58		800
YK1210	D	FA	1,15	50	11800 to 12200
YK1220	D	V/W	16,5		470 to 860
→ YK1223	N	V/W	16,5		470 to 860
→ YK1230	D	V/W	27		470 to 860
→ YK1233	N	V/W	27		470 to 860
→ YK1290	N	V/W	58		470 to 610
→ YK1291	N	V/W	58		590 to 720
→ YK1292	N	V/W	58		710 to 860
→ YK1295	N	V/W	58		470 to 610
→ YK1296	N	V/W	58		590 to 720
→ YK1297	N	V/W	58		710 to 860
YK1300	D	W	600		499,7

Reflex klystrons

type	status	cooling	$W_o$ mW	output	frequency range MHz
→ YK1090	O	N/FA	400	waveguide	10,5 to 12,2
→ YK1091	O	N/FA	400	waveguide	10,5 to 12,2

COOLING: FA = forced air    W = water    V = vapour  
 N = natural    WH = water (helix)    H = heatsink

SURVEY

Travelling-wave tubes

type	status	cooling	$W_o$ W	gain dB	frequency range GHz
LB6-25	M	N/FA	25	38	5,925 to 6,425
YH1090	O	N	25	42	3,4 to 4,2
YH1170	O	H	20	45	5,8 to 8,5
YH1172	O	H	22	45	7,0 to 8,0
	O	H	17	42	8,0 to 8,5
7537	O	N	6	36	4,4 to 5,0
55340	O	N	8	39	3,8 to 4,2

Diodes

type	status	$I_c$ mA	$V_f$ V	$I_f$ mA	frequency MHz
EA52/53	O		6,3	300	1000 ←
K50A	O	150	2	2000	
K51A	O	300	2	3500	
8020	O	100	5	6000	←

T-R switches

type	status				frequency range GHz
56032	O				8,490 to 9,580 ←

COOLING: FA = forced air    W = water    V = vapour  
 N = natural    WH = water (helix)    H = heatsink





HIGH-POWER KLYSTRONS

B





## GENERAL OPERATIONAL RECOMMENDATIONS

### KLYSTRONS

#### 1. GENERAL

##### 1.1 Data

The characteristic data, operational data, capacitance values and curves apply to an average tube which is characteristic of the type of tube in question.

##### 1.2 Reference point of the electrode voltages

If not otherwise stated the electrode voltages are given with respect to the cathode.

##### 1.3 Operational data

The operational data stated in the data sheets do not relate to any fixed setting instructions. They should rather be regarded as recommendations for the effective use of the tube. On account of the tolerances prevailing, deviations from the settings stated may occur.

It is also possible to use other settings, for which purpose the graphs can be used for finding the operational data, or for which purpose interpolation between the settings stated can be performed. If one wishes to deviate from the settings recommended in the data sheets, one should take great care not to exceed the permissible limiting values. If appreciable deviations occur, the manufacturer should be consulted.

A general rule for multi-cavity klystrons is that the focusing voltage must be adjusted so that the cathode current stated will flow.

##### 1.4 D.C. connections

At all times there should be a d.c. connection between each electrode and the cathode. If necessary, limiting values have been stated for the resistance of these connections.

##### 1.5 Mounting and removal

Large klystrons must be mounted in a vertical position, the cathode terminals pointing upwards. Reflex klystrons may as a rule be mounted in any desired position. The instructions relating to each type of tube can be found in the data sheets and the "Instructions for operation and maintenance".

The mounting and removal should be effected with extreme care to avoid damage to the tube. This also applies to rejected tubes, where claims are made under guarantee.

Ferromagnetic parts must not be used in the vicinity of klystrons equipped with a permanent magnet, as this might have a detrimental effect on the operation of the klystron. If necessary, the ceramic insulators and windows must be carefully cleaned, as dirt may damage the klystron on account of local overheating. Naturally the flange of the output cavity must also be thoroughly cleaned so as to prevent arcing.

The "Instructions for operation and maintenance" should in all cases be followed.

##### 1.6 Accessories

Perfect operation of the tubes can only be guaranteed if use is made of the accessories which the manufacturer designed for the tube.



## 1.7 Supply leads

The supply leads to the connections and terminals must be of such a quality that no mechanical stresses, due to differences in temperature or other causes, can occur.

## 1.8 Danger of radiation

In general the absorption in the tissues of the body, and hence the danger, is the greater the shorter the wavelength of the h.f. radiation for equal output. The output of klystrons may be so high that injuries (in particular of the eye) can be inflicted.

Klystrons operated at a high voltage (exceeding 16 kV) may, moreover, emit X-rays of appreciable intensity, which call for protection of the operators.

## 2. LIMITING VALUES

### 2.1 Absolute limiting values

In all cases the limiting values stated are absolute maximum or minimum values. They apply either to all settings or to the various modes of operation. The values stated should in no case be exceeded, neither on account of mains voltage fluctuations and load variations, nor on account of production tolerances in the various building elements (resistors, capacitors, etc.) and tubes, or as a result of meter tolerances when setting the voltages and currents.

Every limiting value should be regarded as the permissible absolute maximum independent of other values. It is not permitted to exceed one limiting value because another is not reached. For instance, one should not allow the limiting value of the collector current to be surpassed while reducing the collector voltage below the permissible limiting value.

If in special cases it should be necessary to exceed a specific limiting value, it is advisable to consult the tube manufacturer, as otherwise no claims can be made.

### 2.2 Protective circuit

To prevent the limiting values of voltages, currents, outputs and temperatures from being exceeded, fast-operating protective circuits must be provided.

### 2.3 Drift current

The limiting value indicated for the drift current is an arithmetical mean value.

## 3. NOTES ON OPERATION

### 3.1 Operational data and variations

When developing electrical equipment the spread in the tube data must be taken into account; if necessary, the tube tolerances can be applied for.

With respect to the spread in the operational data and the average values stated in the data sheets it is recommended that a certain margin be allowed for in the output and input powers when designing equipment intended for series production.

### 3.2 Input power, required driving power

In the data sheets the power stated is the input power  $W_{dr}$  fed to the input cavity and measured between the circulator and this cavity with a 50-ohm resistor serving as a substitute for the load presented by the cavity.

### 3.3 Output power

As a general principle the effective output power is stated.

### 3.4 Sequence of application of the electrode voltages

With multi-cavity klystrons the electrode voltages must be connected in the order given in the operating instructions.

### 3.5 Drift current

When the klystron is driven by an a.m. signal (for instance a video signal), the drift current fluctuates with the modulation. Consequently, the power-supply unit must be designed so as to be suitable for the peak values occurring, which may be appreciably higher than the arithmetical mean values stated.

## 4. HEATING

### 4.1 Type of current

Klystrons can be heated by means of either standard alternating current or direct current. At other frequencies the tube manufacturer should be consulted.

### 4.2 Adjusting the heater voltage

The heater voltage generally governs the adjustment of the heating, while the heater current may deviate from its nominal value within fixed tolerances. The heater voltage should be maintained as accurately as possible. For measuring the heater voltage an r.m.s. voltmeter is required. This meter must be directly connected to the filament terminals of the tube and have an inaccuracy  $< 1,5\%$  in the voltage range concerned. The indicated measuring value should lie in the uppermost third of the scale.

### 4.3 Switching on the heater current

If the data sheet does not contain special data concerning the heater current during switch-on, the tube may be switched on at full heater voltage.

If maximum values are stated for the heater current during switch-on, they relate to the absolute maximum instantaneous value under unfavourable conditions. In the case of a.c. supply this value will occur if the tube is switched on at the maximum amplitude of the highest mains voltage. It is possible to calculate the maximum current during switch-on if the cold resistance and the relationship between the heater current and the heater voltage is known. In practice a heater transformer more or less acting as a leakage transformer is mostly used for limiting the starting current, or a choke coil or resistor is connected in series with the primary of the heater transformer. This choke coil or resistor can be short-circuited by a relay whose action is delayed by about 15 seconds. By means of a calibrated oscilloscope it can be checked whether the starting current remains within the permissible limits; the supply lead may, if necessary, be used as precision resistance.

## 5. COOLING

### 5.1 Forced-air cooling

It is essential that the faces of tubes that are to be cooled by an air-blast should be hit as evenly as possible by the air stream, so as to prevent large differences in temperature which may give rise to mechanical stresses. In many cases (in particular with the large types of tubes) an additional air stream must be directed to the metal-to-glass or metal-to-ceramic seals. The cooling air is usually supplied from a fan via an insulating duct. This air should be filtered, so that all impurities and moisture are removed; in addition to this the radiator must be cleaned at regular intervals. The data concerning the cooling can be found in the data sheets. The cooling must be switched on together with the heating. After the klystron has been switched off cooling air must be supplied for some time; this period depends on the size of the tube and the load. If the cooling of whatever part of the tube is interrupted or if the quantity of cooling air is too small, the collector voltage and the heating must be switched off automatically.

## 5.2 Water cooling

With water-cooled klystrons the cooling equipment is rigidly attached to the tube. If the equipment should be live, the cooling water must be supplied through insulating pipes, of sufficient length.

The water cooling and air cooling for other parts of the tube must be switched on together with the heating. The cooling-water circuit must be arranged so that the water always enters at the bottom, no matter how the tube is mounted. If the pumps should be out of operation, the water jacket(s) of the tube must always be full. In that case after-cooling may in general be done away with.

In many cases the metal-to-glass or metal-to-ceramic seals require additional cooling by a low-velocity air flow. If the cooling-water supply or additional aircooling should fail, the collector voltage and heating must immediately be switched off. Further cooling data can be found in the data sheets.

The specific resistance of the cooling water must be minimum 20 k $\Omega$ -cm, the temporary hardness must be maximum 6 German degrees of hardness. In principle distilled water should be used in the circulation cooler; to reduce the corrosive effect of the distilled water about 700 mg of 24% dyamide hydrate and 700 mg sodium silicate must be added per litre. The pH-value should range from 7 to 9.

If frost is to be expected, a suitable anti-freezing mixture should be added.

## 6. STORAGE

Klystrons may only be stored in their original packing and according to the instructions, so as to avoid damage. For fitting, the tubes must be removed from the packing and directly inserted into the support. In all cases the "Instructions for operation and maintenance" must be adhered to.

In the case of prolonged storage the vacuum of high-power klystrons should be checked at intervals of about three months and improved if necessary, both being possible with the aid of the built-in getter ion pump and a suitable power supply/test unit. During this operation the heater supply should preferably be turned on slowly.

## U.H.F. POWER KLYSTRONS

Power amplifier klystrons in metal-ceramic construction designed for four external resonant cavities, magnetic beam focusing, continuous operating getter-ion pump. The tubes are intended for use as u.h.f. power amplifier in TV transmitters.

## QUICK REFERENCE DATA

Frequency range	
YK1000	400 to 620 MHz
YK1004	610 to 790 MHz
Power output	11 kW
Power gain	30 dB
Cooling	water and air

**HEATING:** indirect by a.c. or d.c.

Cathode	dispenser type
Heater voltage	$V_f$ 7,5 to 8 V
During operation the applied heater voltage should not fluctuate more than $\pm 3\%$ .	
Heater current	$I_f$ 32 ( $\leq 36$ ) A
The heater current should never exceed a peak value of 80 A when applying an a.c. heater voltage or 65 A when applying a d.c. heater voltage.	
Cold heater resistance	$R_{fo}$ 28 m $\Omega$
Waiting time	$t_w$ unit 180 s

## GETTER-ION PUMP POWER SUPPLY

Pump voltage,	
unloaded (cathode reference)	3,9 kV
loaded ( $\approx 3$ mA)	3,0 kV
Internal resistance	approx. 300 k $\Omega$

## FOCUSING COILS POWER SUPPLY

Focusing coil	
voltage	35 to 50 V
current	1,0 to 1,5 A
Focusing coils for drift tubes (connected in series)	
voltage	250 to 500 V
current	1,8 to 2,8 A

**COOLING**

Cathode base	low velocity air flow
Accelerating electrode	low velocity air flow
Drift tubes	water or glycol solution (30%) q = 2 ℓ/min, T <sub>i</sub> = max. 60 °C
Output resonator	forced air q = 2 m <sup>3</sup> /min at T <sub>i</sub> = 20 °C
Collector	water or glycol solution (30%) See cooling curves, Figs 4 and 5

**MOUNTING**

Vertical, cathode up. All connections should be free from strain.

**ACCESSORIES**

Heater connector	type 40649
Heater/cathode connector	type 40649
Focusing electrode connector	type 40634
Accelerating electrode connector	type TE1052
Ion pump connector	type 55351
Magnet unit for ion pump	type TE1053
Collector connector for YK1004 only	type 40634

**MASS (net)**

YK1000	approx. 30 kg
YK1004	approx. 40 kg

**LIMITING VALUES (Absolute maximum rating system)**

Unless otherwise mentioned all voltages are specified with respect to ground.

Cathode voltage	max.	-20 kV
Cathode voltage at zero current	max.	-21 kV
Cathode current	max.	2,1 A
Total drift tube current	max.	100 mA
Focusing electrode to cathode voltage	max.	-500 V
Pump voltage (cathode reference)	max.	4 kV
Pump current	max.	15 mA
Temperature limits		
cathode base	max.	125 °C
accelerating electrode	max.	125 °C
Collector dissipation	max.	50 kW



**OPERATING CONDITIONS**

As a 10 kW TV vision amplifier in the band 470 MHz to 790 MHz according to the CCIR system with negative modulation. Unless otherwise mentioned all voltages are specified with respect to ground.

Cathode voltage	19,0	18,0 kV
Focusing electrode to cathode voltage	-250	-200 V
Cathode current	2,05	2,0 A
Drift tube current,		
static	40	40 mA
dynamic	50	50 mA

For optimum operating conditions the electron beam should be focused for minimum drift tube current.

Driving power, sync	see Fig. 1	
Output power, sync	11	11 kW
Power gain	30	30 dB

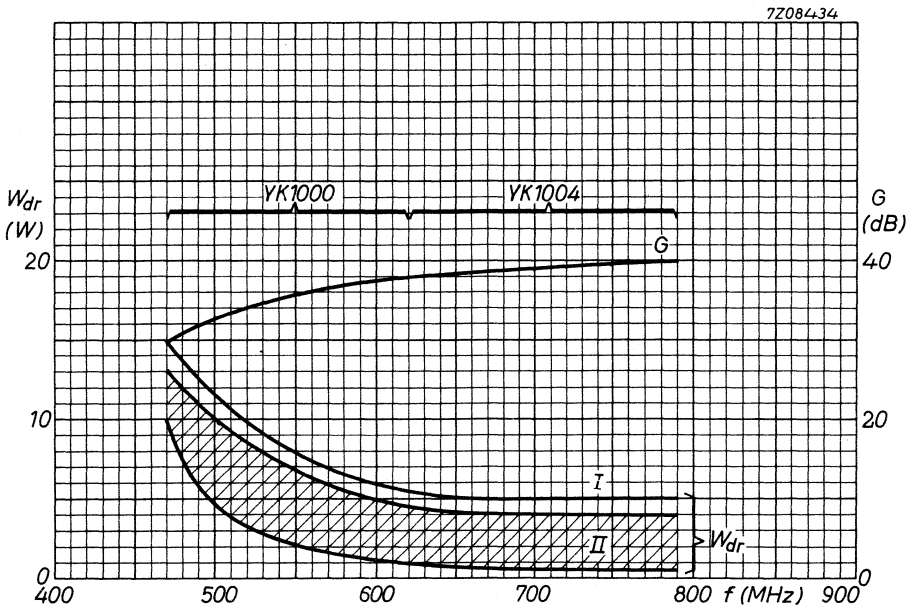

Fig. 1.

- I. Maximum driving power with circulator between driver and first resonator, measured at circulator point.
- II. Driving power with circulator between driver and first resonator, measured between circulator and first resonator.

MECHANICAL DATA YK1000

Dimensions in mm

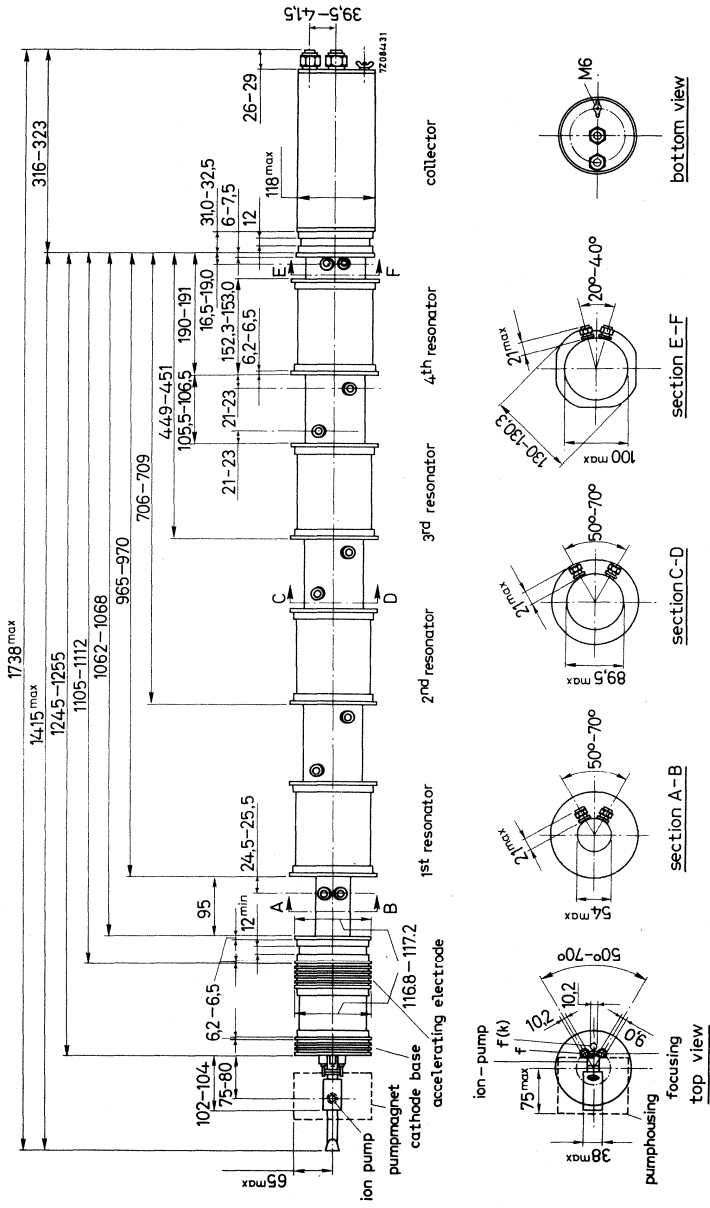

Fig. 2.

YK1004

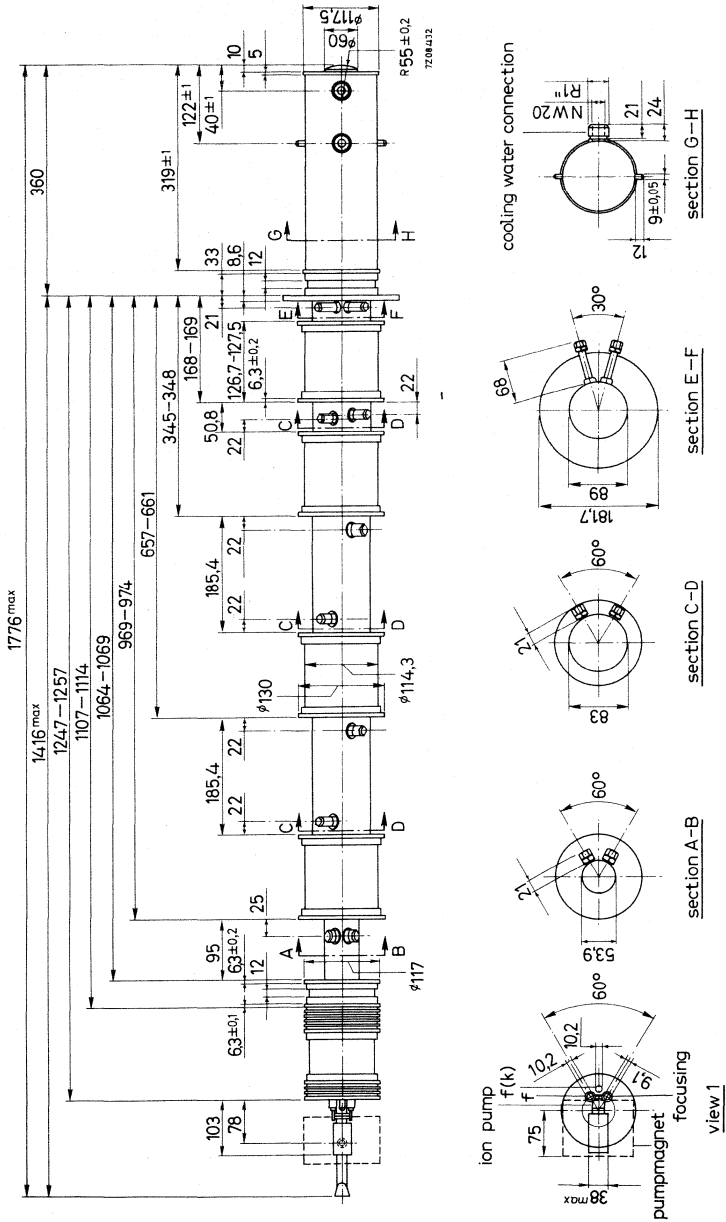

Fig. 3.

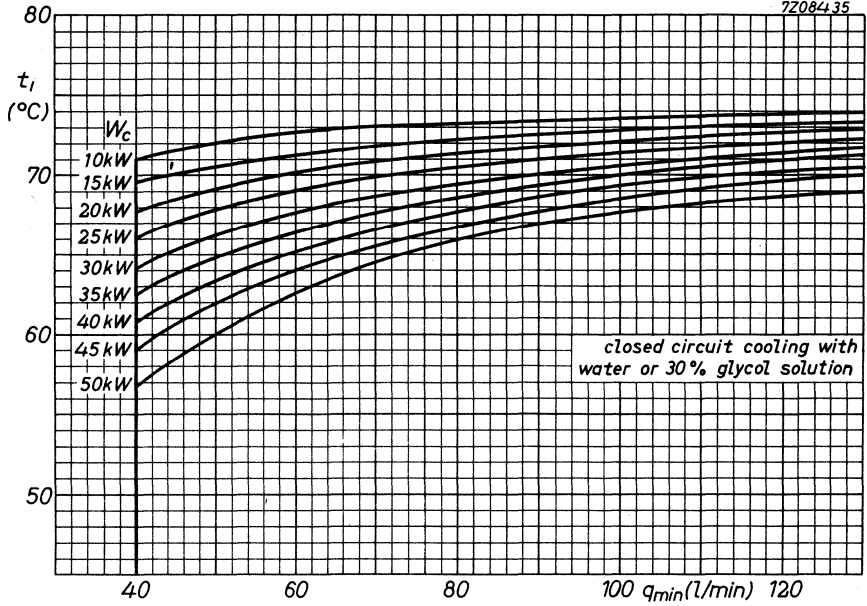

Fig. 4.

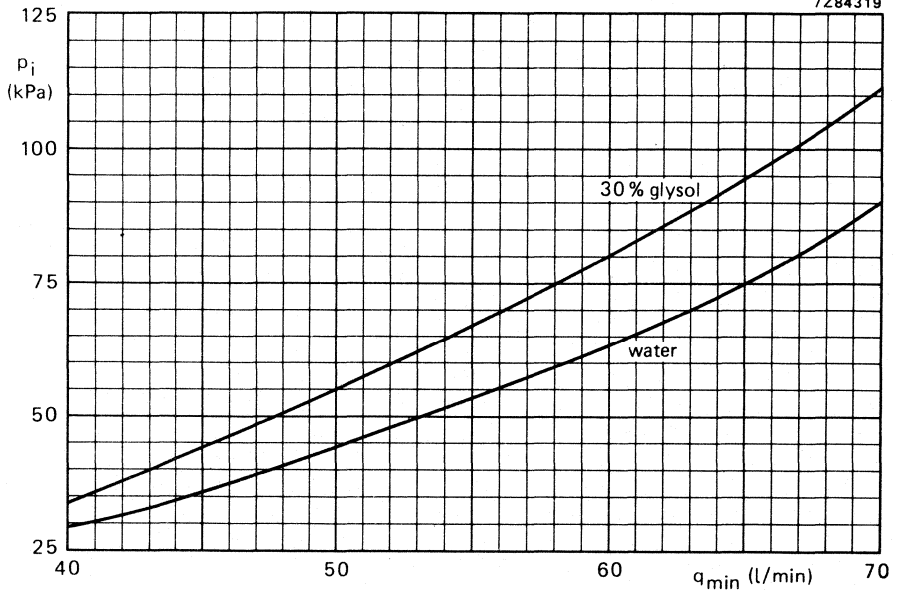

Fig. 5.

## U.H.F. POWER KLYSTRONS

Power amplifier klystrons in metal-ceramic construction for the frequency band 470 MHz to 860 MHz designed for four external resonant cavities, beam focusing by means of permanent magnets, continuously operating getter-ion pump and operation with a depressed collector potential. These klystrons are intended for use as u.h.f. power amplifier in vision and/or sound transmitters for the TV bands IV and V.

## QUICK REFERENCE DATA

Frequency range	470 to 860 MHz
Power output	11 kW
Power gain	30 dB
Cooling	
YK1001: air-cooled drift tubes and air-cooled collector	
YK1002: air-cooled drift tubes and water-cooled, or, optionally, vapour-cooled collector	

**HEATING:** indirect by a.c. or d.c.

Cathode	dispenser type
Heater voltage	$V_f$ 7,5 to 8,0 V

During operation the applied heater voltage should not fluctuate more than  $\pm 3\%$ . It is advised to operate the klystron at 8 to 8,5 V (including mains fluctuations) during the first 300 hours. The heater voltage should then be reduced to 7,5 to 8,0 V.

Heater current	$I_f$ 32 ( $\leq 36$ ) A
----------------	--------------------------

The heater current should never exceed a peak value of 80 A when applying an a.c. heater voltage or 65 A when applying a d.c. heater voltage.

Cold heater resistance	$R_{fo}$ 28 m $\Omega$
Waiting time	$t_w$ min. 180 s

**GETTER-ION PUMP POWER SUPPLY**

Pump voltage, unloaded (cathode reference)	4,0 kV
Internal resistance	approx. 300 k $\Omega$

### COOLING

Except collector, applicable up to an air-inlet temperature  $T_i$  of 40 °C and an altitude of 3000 m (values refer to air inlet).

Cathode base	air, $q$ = approx. 0,5 m <sup>3</sup> /min
Accelerating electrode	air, $q$ = approx. 0,5 m <sup>3</sup> /min
Drift tubes 1, 2 and 3	air, $q$ = approx. 1,0 m <sup>3</sup> /min each
Drift tube 4	air, $q$ = approx. 1,5 m <sup>3</sup> /min
Drift tube 5	forced air, $q$ = approx. 1,5 m <sup>3</sup> /min ( $p_i = 900 P_a$ )
Resonant cavity D	forced air, $q$ = approx. 2,0 m <sup>3</sup> /min ( $p_i = 900 P_a$ )
Collector YK1001	forced air, see cooling curves Figs 3, 4 and 5
Collector YK1002	water, see cooling curves Figs 6 and 7.

### MOUNTING

Vertical, cathode up, In order to prevent distortion of the magnetic focusing field ferromagnetic material should not be used within a radius of 35 cm from the tube axis. All connections should be free from strain.

### ACCESSORIES

Heater connector	type 40649
Heater/cathode connector	type 40649
Focusing electrode connector	type 40634
Accelerating electrode connector	type 40634
Collector connector	type 40634
Ion pump connector	type 55351
Magnet unit for ion pump	type TE1053
Set of five pairs of focusing magnets	type TE1065 (2xA, 2xB, 2xC, 2xD, 2xE)*
Set of four resonant cavities for 470 MHz to 790 MHz	type TE1066 (3xA, 1xD)
or	
Set of four resonant cavities for 700 MHz to 860 MHz	type TE1067 (3xA, 1xD)
2 magnet field adaptor plates for collector (YK1001 only)**	type TE1073
Circulators, temperature compensated up to 70 °C (optional)	type 2722 162 01061 (470 MHz to 600 MHz) 01071 (590 MHz to 720 MHz) 01081 (710 MHz to 860 MHz) 01101 (608 MHz to 790 MHz)

### MASS (net)

YK1001	approx. 55 kg
YK1002	approx. 45 kg
Total mass of accessories	approx. 125 kg

\* If the klystron is used under TV transposer conditions replace 2xB by 2xE.

\*\* When operating with a collector voltage less than -2kV these plates should be fitted along the collector in order to keep the collector temperatures below the maximum values. See "Instructions for operation and maintenance".

MECHANICAL DATA

Dimensions in mm

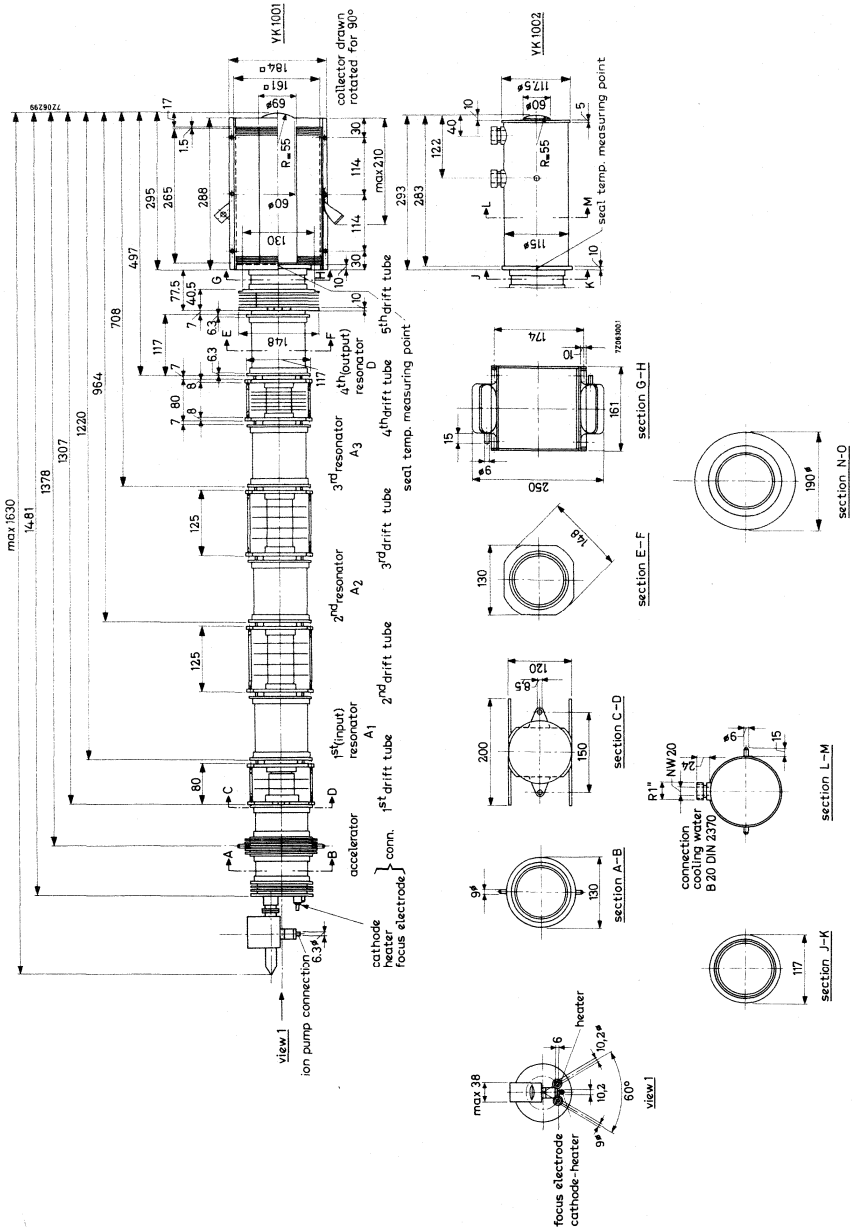

Fig. 1.

MECHANICAL DATA (continued)

Dimensions in mm

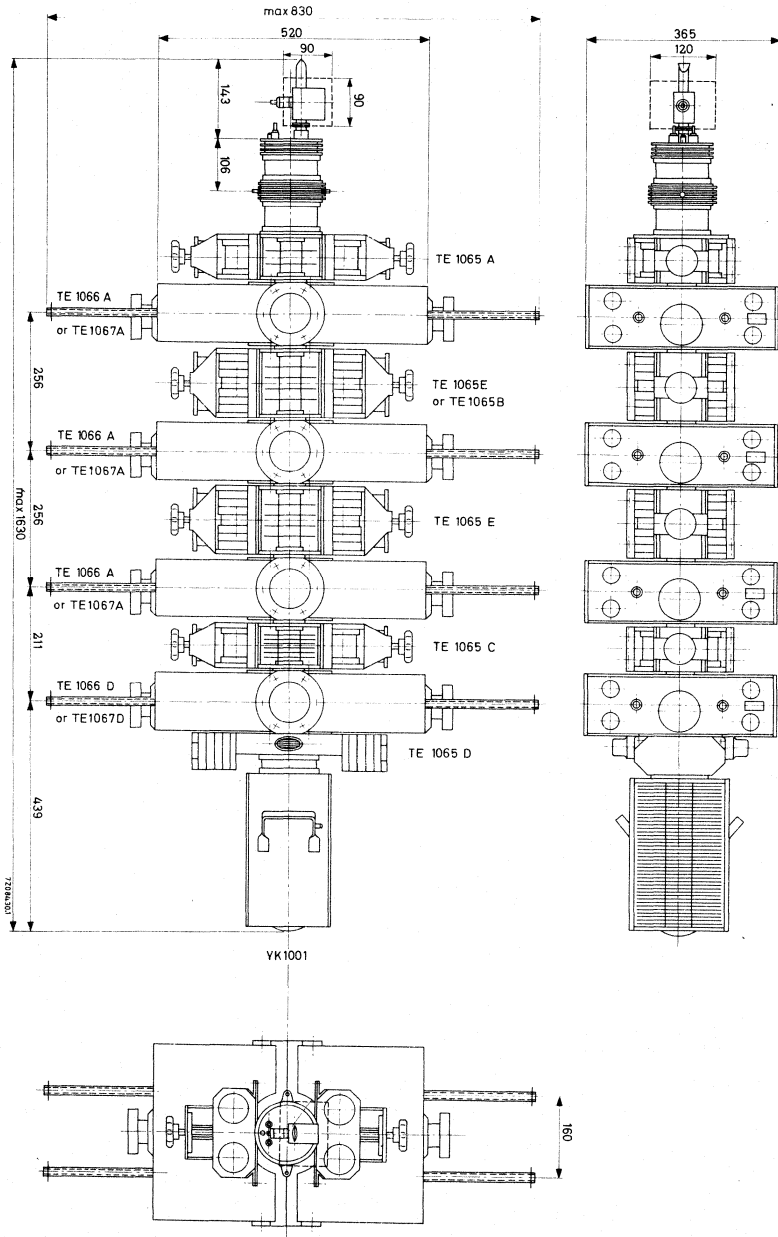

Fig. 2.



**LIMITING VALUES** (Absolute maximum rating system)

Unless otherwise mentioned all voltages are specified with respect to ground.

Heater voltage	max.	8,5 V
Cathode voltage	max.	-22 kV
Cathode voltage at zero current	max.	-25 kV
Accelerating electrode voltage at zero current	max.	-25 kV
Collector voltage	max.	-7 kV
	min.	-0,5 kV
Focusing electrode to cathode voltage	max.	-700 V
	min.	-100 V
Series resistance in accelerating electrode circuit	max.	20 k $\Omega$
	min.	10 k $\Omega$
Cathode current	max.	2,3 A
Drift tube current*	max.	150 mA
Beam power	max.	42 kW
Collector dissipation	max.	40 kW
Voltage standing-wave ratio	max.	1,5
Pump voltage	max.	4,5 kV
Pump current	max.	15 mA
Temperature of		
cathode base and accelerating electrode	max.	125 °C
drift tubes 1, 2 and 3	max.	80 °C
drift tubes 4 and 5	max.	150 °C
resonant cavity D	max.	125 °C
collector seal YK1001	max.	200 °C
collector body YK1001**	max.	300 °C
outlet cooling water YK1002	max.	75 °C



\* The limiting values for various operating conditions are given in Fig. 8.

\*\* For safeguarding this temperature limit it is recommended that the air outlet temperature be measured at least at two places; one at 50 mm and one at 150 mm from the upper collector plate and at a distance of 50 mm from the cooling fins. See also "Instructions for operation and maintenance".

**OPERATING CONDITIONS**

Unless otherwise mentioned all voltages are specified with respect to ground. During operation the applied voltages should not fluctuate more than  $\pm 3\%$ .

**As 5 kW and 10 kW vision amplifier** in the band 470 MHz to 860 MHz in accordance with the CCIR system with negative modulation. notes  
2,3

Bandwidth ( $-1$  dB): 6 MHz.

Output power, peak sync	5,5	5,5	11	11 kW		
Driving power, peak sync	8	8	10	10 W	4,5,6	
Power gain	30	30	30	30 dB	4	
Cathode to collector voltage	-16,0	-11,5	-18	-13,5 kV	7	
Collector voltage	-0,5	-5	-0,5	-5 kV	8	
Accelerating electrode voltage	0	0	0	0 kV	9	
Focusing electrode to cathode voltage	$\approx$ -400	-400	-400	-400 V	16	
Cathode current	1,6	1,6	1,9	1,9 A		
Drift tube current, static		25	30	25	30 mA	10
black level	$\approx$	40	80	40	100 mA	11
Differential gain	$\approx$	80	80	80	80 %	12
Sync compression	$\leq$	45/25	45/25	45/25	45/25	13
V.S.B. suppression	$\leq$	-20	-20	-20	-20 dB	14
Noise with reference to black level	$\leq$	-46	-46	-46	-46 dB	15

Tuning of cavities with respect to carrier frequency

Cavity A1	approx.	+3 MHz
Cavity A2	approx.	-0,5 MHz
Cavity A3	approx.	+4,5 MHz
Cavity D	approx.	0 MHz

External cavity loading at black level for 11 kW sync power output

Cavity A1	max.	5 W
Cavity A2	max.	100 W
Cavity A3	max.	200 W

**As 1 kW, 2 kW and 4 kW TV sound amplifier** in the band 470 to 860 MHz 2,3

Output power		1,1	1,1	2,2	2,2	4,4	4,4 kW	
Driving power	$\leq$	0,5	0,5	0,5	0,5	0,5	0,5 W	4,5
Cathode to collector voltage		-18	-13,5	-18	-13,5	-18	-13,5 kV	7
Collector voltage		-0,5	-5	-0,5	-5	-0,5	-5 kV	
Accelerating electrode voltage		-9	-9	-7,5	-7,5	-5,5	-5,5 kV	
Focusing electrode to cathode voltage	$\approx$	-400	-400	-400	-400	-400	-400 V	
Cathode current		0,5	0,5	0,7	0,7	1,0	1,0 A	
Drift tube current dyn	$\approx$	40	50	40	50	50	70 mA	10

For notes see next page.

## Notes

1. Fluctuations of the beam voltage up to  $\pm 3\%$  will not damage the tube; to meet the signal-transfer quality requirements the nominal beam voltage should not vary more than  $\pm 1\%$ .
2. With the appropriate focusing magnets TE1065, cavities TE1066 and a circulator between the driver and input cavity A1.
3. In case of a failure all electrode voltages for the klystron except the pump and heater voltages should be switched off, and reduced to less than 5% of the nominal value within 500 ms after the failure has occurred.
4. Dependent on operating frequency, see Fig. 9.
5. The driving power  $W_{dr}$  is measured between the circulator and the first cavity at a  $50 \Omega$  resistance and represents the sum of the forward and the reflected power in the first cavity.
6. A pre-correction is to be introduced in the pre-stage to compensate for the level dependency of the bandpass curve caused by non-linearities of the klystron, see "Instructions for operation and maintenance".
7. At frequencies above 790 MHz a higher beam power is required to meet the nominal output requirement. Operating data on request.
8. When operating with a collector voltage less than  $-2$  kV the temperature-compensating plates TE1073 should be fitted along the collector. See "Instructions for operation and maintenance".
9. It is recommended that this voltage be obtained from a voltage divider between cathode and ground, which should carry a quiescent current of minimum 3 mA.
10. To be focused for minimum drift tube current.
11. At black level, to be focused for minimum drift tube current. If necessary to obtain the required signal-transfer quality, a deviation of maximum 10% from this minimum current is permitted. The limiting value, see Fig. 8, may however, not be exceeded.
12. Measured with a sawtooth voltage with amplitude between 17 and 75% of the peak sync value, on which is superimposed a 4,43 MHz sinewave with a 10% peak-to-peak value.
13. A picture/sync ratio of 75/25 for the outgoing signal of the klystron requires a ratio of maximum 55/45 for the incoming signal.
14. Measured with 10 to 70% modulation, without compensation. V.S.B. filter between driver and klystron.
15. Produced by the klystron itself, without hum from power supplies.
16. The power supply should be adjustable from  $-100$  V to  $-700$  V and be preloaded with min. 10 mA at  $-700$  V.



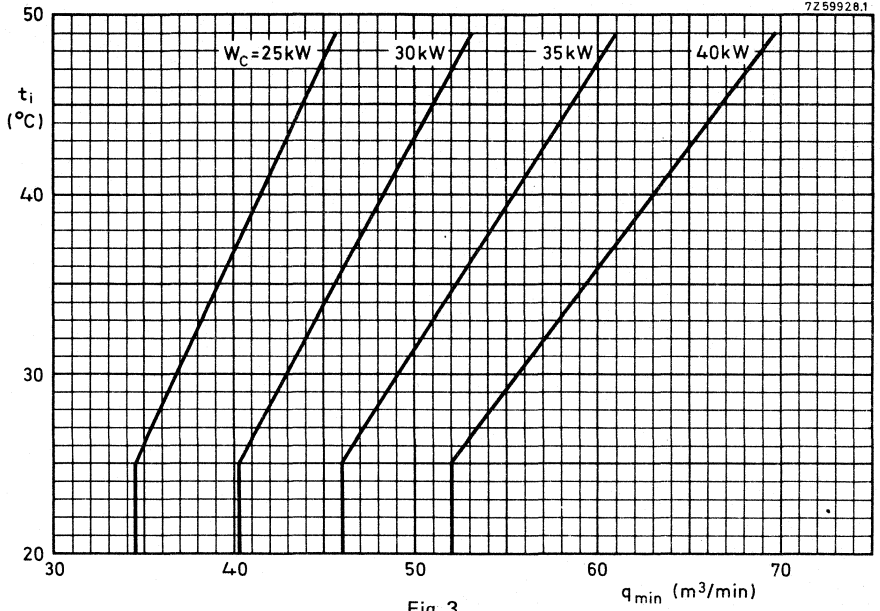

Fig. 3.

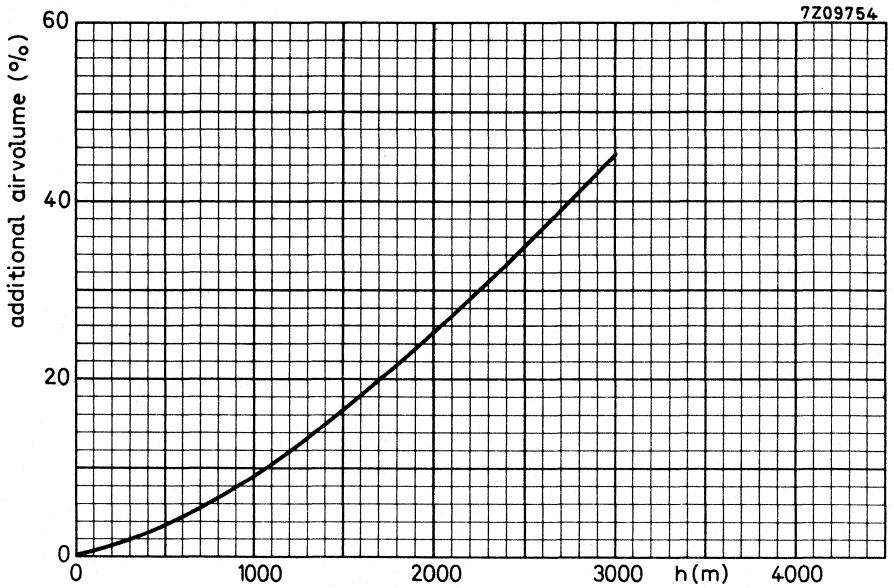

Fig. 4.

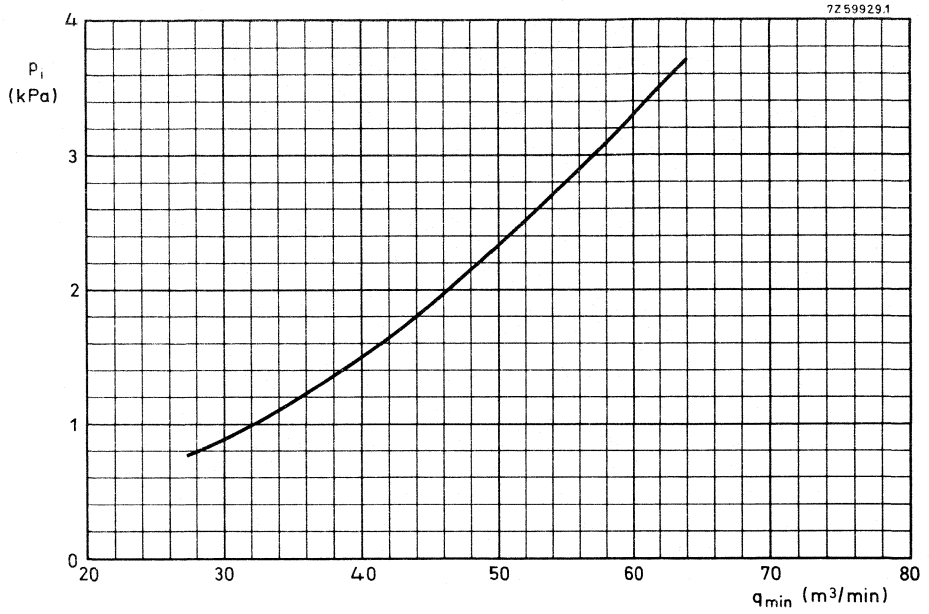

Fig. 5 Ratio of cooling air pressure to cooling air volume of YK1001.

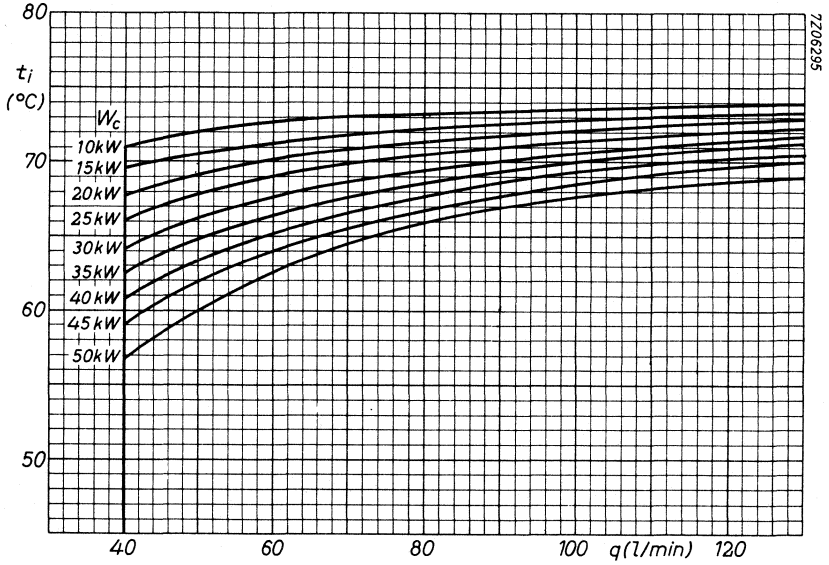

Fig. 6 Cooling curves for top water or closed circuit cooling with 30% glycol solution for YK1002.

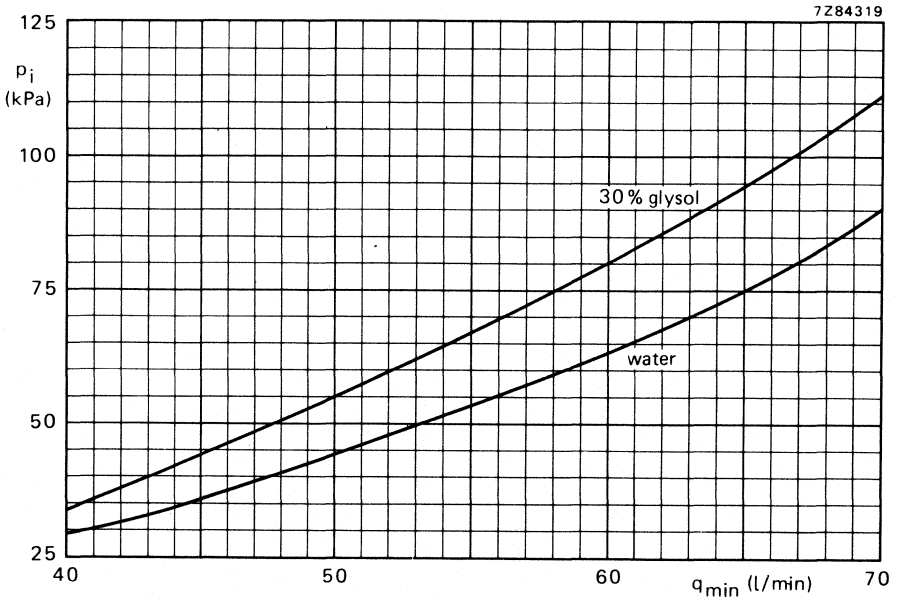

Fig. 7 Ratio of cooling water pressure to cooling water volume for YK1002.

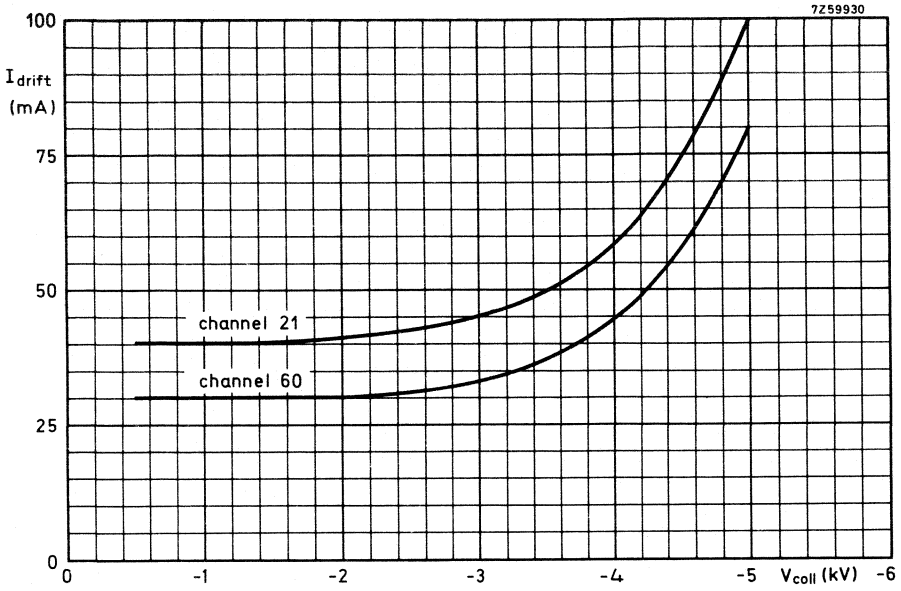

Fig. 8.

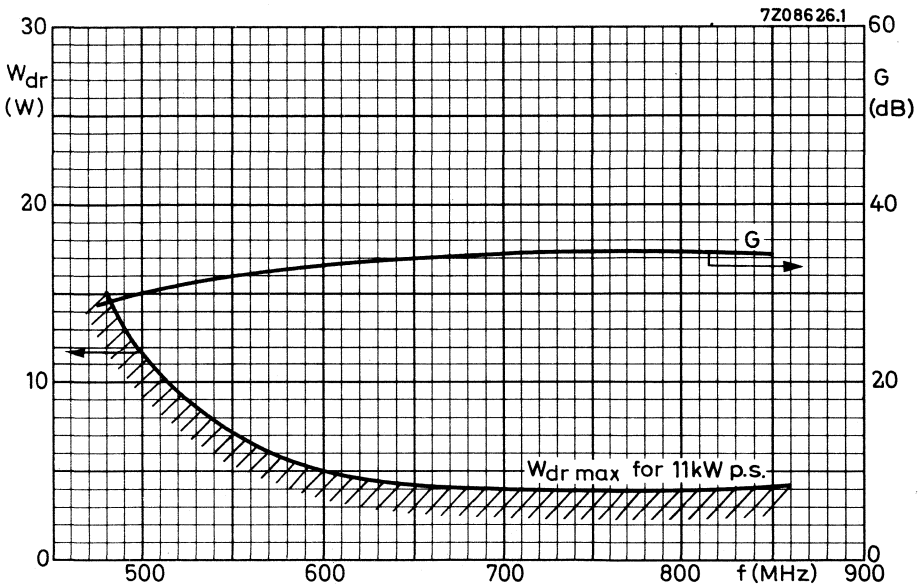

Fig. 9.





## U.H.F. POWER KLYSTRON

Air-cooled power amplifier klystron in metal-ceramic construction for the frequency range 470 to 860 MHz, designed for four external resonant cavities, beam focusing by means of permanent magnets, continuously operating getter-ion pump and operation with depressed collector potential. This klystron is intended for use as u.h.f. power amplifier in vision and/or sound transmitters as well as in translators for the TV bands IV and V.

## QUICK REFERENCE DATA

Frequency range, covered with two sets of resonators	470 to 860 MHz
Power output (vision amplifier)	11 kW
Power gain	≈ 40 dB

**HEATING:** indirect by a.c. or d.c.

Cathode	dispenser type
Heater voltage	$V_f$ 7,5 to 8,0 V

During operation the applied heater voltage should not fluctuate more than  $\pm 3\%$ . It is advised to operate the klystron at 8,0 V (including mains fluctuations) during the first 300 hours. The heater voltage should then be reduced to 7,5 to 8,0 V.

Heater current	$I_f$ 32 ( $\leq 36$ ) A
----------------	--------------------------

The heater current should never exceed a peak value of 80 A when applying an a.c. heater voltage or 65 A when applying a d.c. heater voltage.

Cold heater resistance	$R_{fo}$ 28 m $\Omega$
Waiting time	$t_w$ min. 180 s

## GETTER-ION PUMP POWER SUPPLY

Pump voltage, unloaded (cathode reference)	4,0 kV
Internal resistance	approx. 300 k $\Omega$

**COOLING**

Applicable up to an air-inlet temperature  $T_i$  of 40 °C and an altitude of 3000 m (values refer to air-inlet).

Cathode base	air, $q$ = approx. 0,5 m <sup>3</sup> /min
Accelerating electrode	air, $q$ = approx. 0,5 m <sup>3</sup> /min
Drift tubes 1, 2 and 3	air, $q$ = approx. 1,0 m <sup>3</sup> /min each
Drift tube 4	air, $q$ = approx. 1,5 m <sup>3</sup> /min
Drift tube 5	forced air, $q$ = approx. 1,5 m <sup>3</sup> /min ( $p_i$ = 900 Pa)
Resonant cavity (output)	forced air, $q$ = approx. 2,0 m <sup>3</sup> /min ( $p_i$ = 900 Pa)
Collector	forced air, see cooling curves Figs 3, 4 and 5

**MOUNTING**

Vertical, cathode up. In order to prevent distortion of the magnetic focusing field, ferromagnetic material should not be used within a radius of 35 cm from the tube axis. All connections should be free from strain.

**ACCESSORIES**

Heater connector	type 40649
Heater/cathode connector	type 40649
Focusing electrode connector	type 40634
Accelerating electrode connector	type 40634
Collector connector	type 40634
Ion pump connector	type 55351
Magnet unit for ion pump	type TE1053 (1x)
Set of four resonant cavities for 470 MHz to 650 MHz, or	type TE1056G (3x)
Set of four resonant cavities for 650 MHz to 860 MHz	type TE1056H (1x)
Focusing magnets	type TE1067A (3x)
	type TE1067D (1x)
	type TE1065A (2x)
	type TE1065C (2x)
	type TE1065E (4x)
	type TE1065G (2x)
	type TE1065H (2x)
	type TE1071 (1x)
Air duct	type 2722 162 01061 (470 MHz to 600 MHz)
Circulators, temperature compensated up to 70 °C (optional)	162 01071 (590 MHz to 720 MHz)
	162 01081 (710 MHz to 860 MHz)
	162 01101 (608 MHz to 790 MHz)

**MASS (net)**

YK1005	approx. 60 kg
Total mass of accessories	approx. 130 kg

MECHANICAL DATA

Dimensions in mm

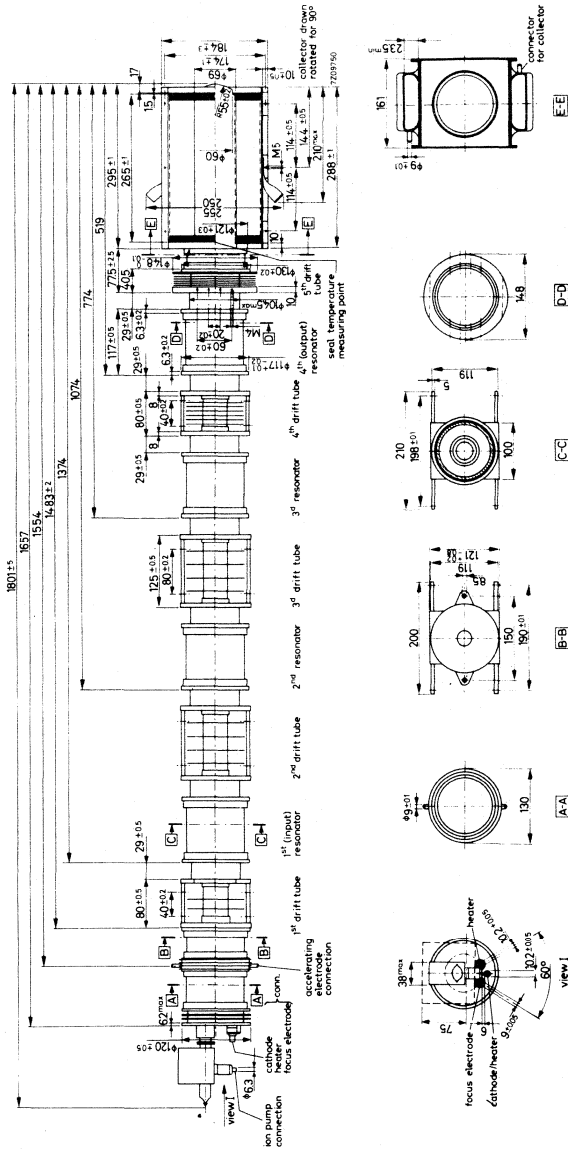

Fig. 1



**LIMITING VALUES** (Absolute maximum system)

Unless otherwise mentioned all voltages are specified with respect to ground.

Heater voltage	max.	8,5 V	
Cathode voltage	max.	-22 kV	
Cathode voltage at zero current	max.	-25 kV	
Accelerating electrode voltage at zero current	max.	-25 kV	
Collector voltage	max.	-7 kV	
	min.	-0,5 kV	
Focusing electrode voltage (cathode reference)	max.	-700 V	
	min.	-100 V	
Series resistance in accelerating electrode circuit	max.	20 k $\Omega$	
	min.	10 k $\Omega$	
Cathode current	max.	2,3 A	
Drift tube current	max.	150 mA	
Collector dissipation	max.	40 kW	
Voltage standing-wave ratio	max.	1,5	
Pump voltage	max.	4,5 kV	
Pump current	max.	15 mA	
Temperature of			
	cathode and accelerating electrode	max.	125 °C
	drift tubes 1, 2 and 3	max.	80 °C
	drift tubes 4 and 5	max.	150 °C
	resonant cavity (output)	max.	125 °C
	collector seal	max.	200 °C
collector body*	max.	300 °C	

\* For safeguarding this temperature limit it is recommended that the air outlet temperature be measured at least at two places; one at 50 mm and one at 150 mm from the upper collector plate and at a distance of 50 mm from the cooling fins.

**OPERATING CONDITIONS** (for depressed collector operation)

Unless otherwise mentioned all voltages are specified with respect to ground. notes  
 During operation the applied voltages should not fluctuate more than  $\pm 3\%$ .  
 Measured with focusing magnets TE1065 and cavities TE1056 or TE1067. 1

**As 10 kW vision amplifier** in the band 470 MHz to 860 MHz in accordance with the CCIR system with negative modulation. Bandwidth ( $-1$  dB): 6 MHz. 2,3

Frequency	470	790 MHz	
Output power, peak sync	11	11 kW	
Driving power, peak sync	2	< 1 W	4,5,6
Power gain	38	> 40 dB	4
Cathode to collector voltage	-13,5	-16 kV	
Collector to body voltage	-4	-4 kV	
Accelerating electrode to body voltage	0	0 kV	7
Focusing electrode to cathode voltage	-240	-600 V	14
Cathode current	2,0	1,85 A	
Body current,			
static	30	30 mA	8
black level	80	60 mA	9
Linearity	80	80 %	10
Sync compression	$\leq 45/25$	$\leq 45/25$	11
V.S.B. suppression	-20	-20 dB	12
Noise with reference to black level	-46	-46 dB	13

**Tuning of cavities with respect to carrier frequency**

Cavity 1	approx.	+3 MHz
Cavity 2	approx.	-0,5 MHz
Cavity 3	approx.	+4,5 MHz
Cavity 4	approx.	0 MHz

**External cavity loading at black level for 11 kW sync power output**

Cavity 1	max.	5
Cavity 2	max.	100
Cavity 3	max.	200

**As 2 or 4 kW sound amplifier** in the band 470 MHz to 860 MHz 2,3

Output power	2,2	4,4 kW
Driving power	$\leq 0,5$	$\leq 0,5$ W
Cathode to collector voltage	-13,5	-13,5 kV
Collector to body voltage	-5	-5 kV
Accelerating electrode to body voltage	-7,5	-5,5 kV
Focusing electrode to cathode voltage	-400	-400 V
Cathode current	0,7	1,0 A
Body current	50	70 mA

For notes see next page.

**Notes**

1. Fluctuations of the beam voltage up to  $\pm 3\%$  will not damage the tube; to obtain a good signal-transfer quality the nominal beam voltage should not vary more than  $\pm 1\%$ .
2. With a circulator between the driver stage and input cavity 1.
3. In case of operating failures all klystron-electrode voltages except the pump and heater voltages should be switched off and made to drop to less than 5% of the nominal value within 500 ms after occurrence of this failure.
4. Dependent on operating frequency, see Fig. 6.
5. The driving power  $W_{dr}$  is measured between the circulator and first cavity at a  $50 \Omega$  resistance and represents the sum of the forward and the reflected power in the first cavity.
6. A pre-correction network is to be incorporated in the pre-stage to compensate for the level dependency of the bandpass characteristic caused by non-linearities of the klystron.
7. It is recommended that this voltage be obtained from a voltage divider between cathode and ground, which should carry a quiescent current of min. 3 mA.
8. To be focused for minimum body current.
9. At black level to be focused for minimum body current. If necessary, to obtain the required signal-transfer quality, a deviation of max. 10% from this minimum current is permitted.
10. Measured with a sawtooth voltage with amplitude between 17% and 75% of the peak sync value, on which is superimposed a 4,43 MHz sinewave with a 10% peak-to-peak value.
11. A picture/sync ratio of 75/25 for the outgoing signal of the klystron requires a ratio of max. 55/45 for the incoming signal.
12. Measured with modulation 10 to 75%, without compensation, V.S.B. filter between driver and klystron.
13. Produced by the klystron itself; excluded hum from power supplies.
14. The power supply should be adjustable from  $-100 \text{ V}$  to  $-700 \text{ V}$  and be pre-loaded with min. 10 mA at  $-700 \text{ V}$ .



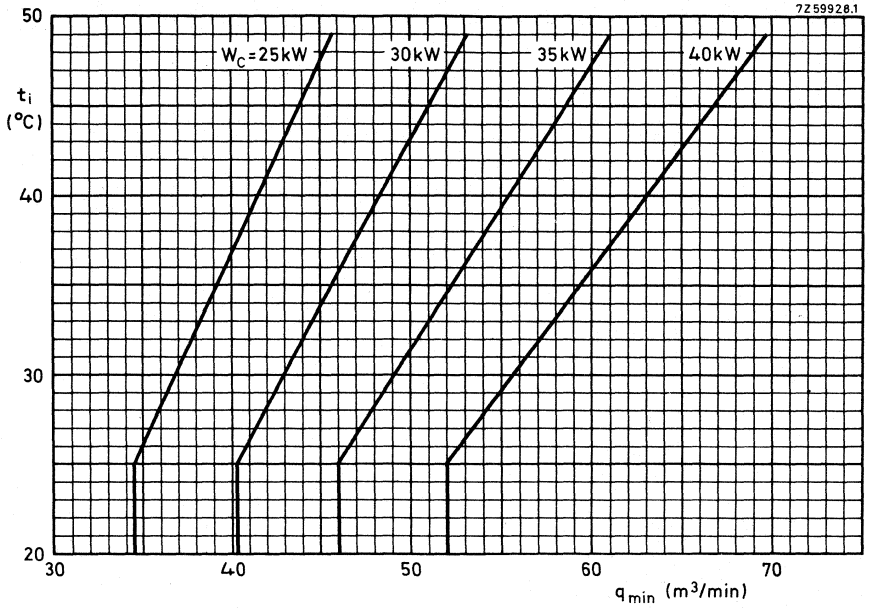

Fig. 3.

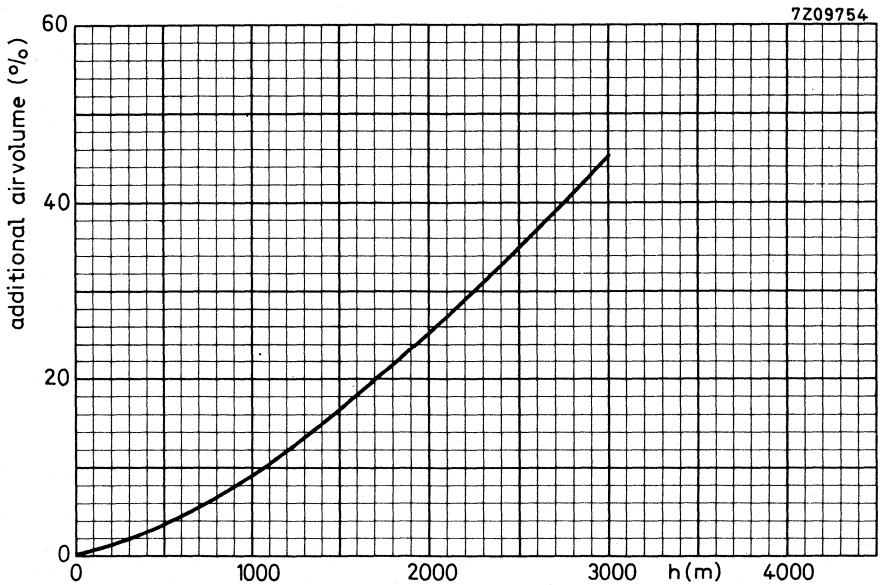

Fig. 4.



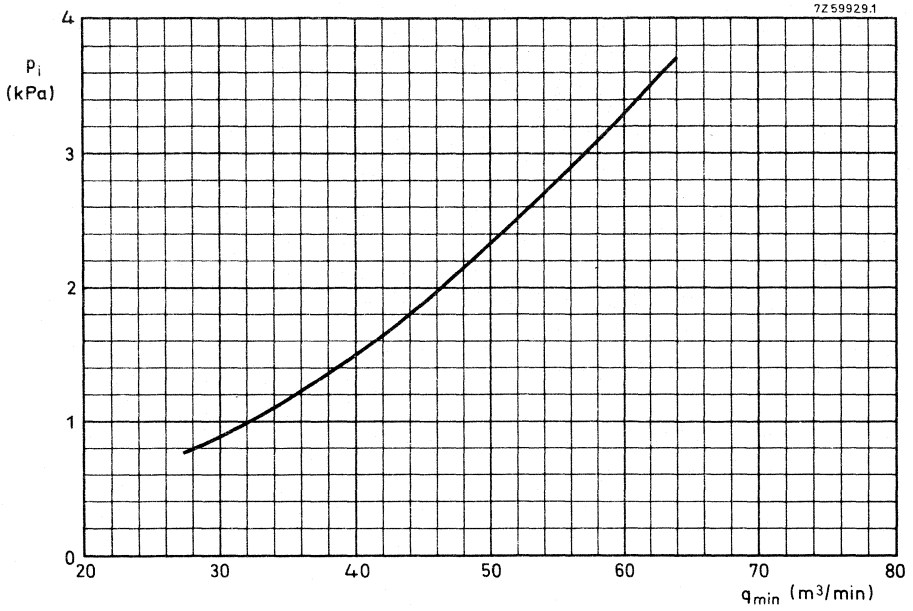

Fig. 5.

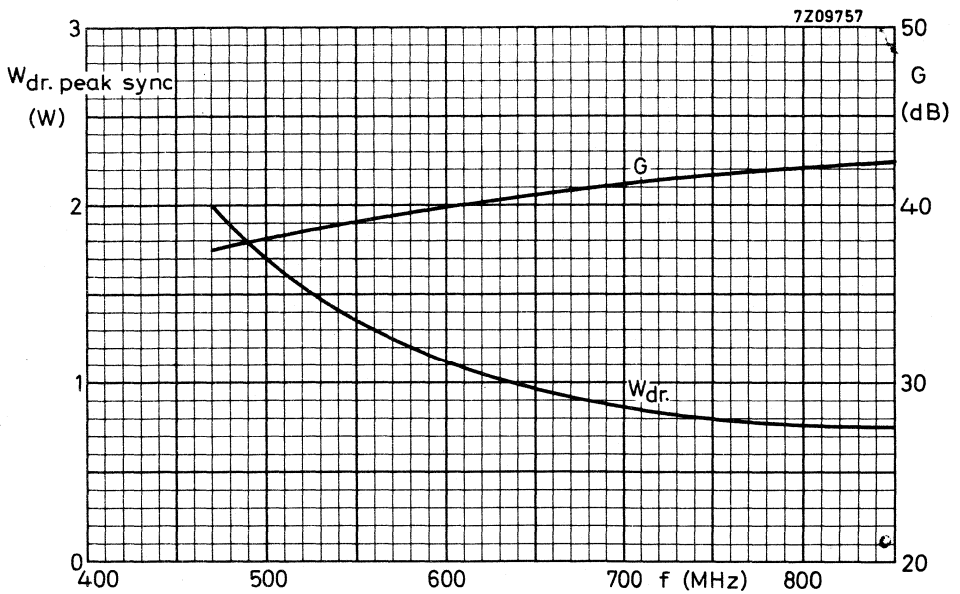

Fig. 6.



## PULSED POWER KLYSTRON

Fixed frequency pulsed power klystron in metal-ceramic construction for the range  $2998 \pm 5$  MHz, with 3 internal cavities, electromagnetic focusing, continuously operating getter-ion pump, coaxial input connector and S-band output waveguide, water cooled, intended as amplifier in linear accelerators and similar applications.

### QUICK REFERENCE DATA

Frequency range	f	$2998 \pm 5$ MHz
The klystron is factory tuned to 2998 MHz but can delivered for any frequency within the range 2993 MHz to 3003 MHz. Other frequencies on request.		
Peak power output	$W_{op}$	6 MW
Power gain	G	30 dB

**HEATING:** indirect by a.c. or d.c.

Cathode	oxide coated	
Heater voltage	$V_f$	3 to 4.6 V
Heater current, marked on each tube	$I_f$	70 to 82 A
The heater current should never exceed a peak value of 150 A when applying an a.c. heater voltage or 100 A when applying a d.c. heater voltage.		
Cold heater resistance	$R_{f0}$	6 m $\Omega$
Waiting time	$t_w$ min.	45 min.

### GETTER-ION PUMP POWER SUPPLY

Pump voltage, unloaded		4 kV
Internal resistance	approx.	300 k $\Omega$

**COOLING** (valid for a pulse repetition rate up to 50 p.p.s.)

Drift tubes and focusing coils	q	min.	4 l/min.
	p	max.	350 Pa
Collector	q	min.	7 l/min.
	p	max.	350 Pa

### ACCESSORIES

Magnet and housing for getter-ion pump	type TE1053A and TE1053B
--	-----------------------------

MASS (net)	approx.	110 kg
------------	---------	--------

MECHANICAL DATA

Dimensions in mm

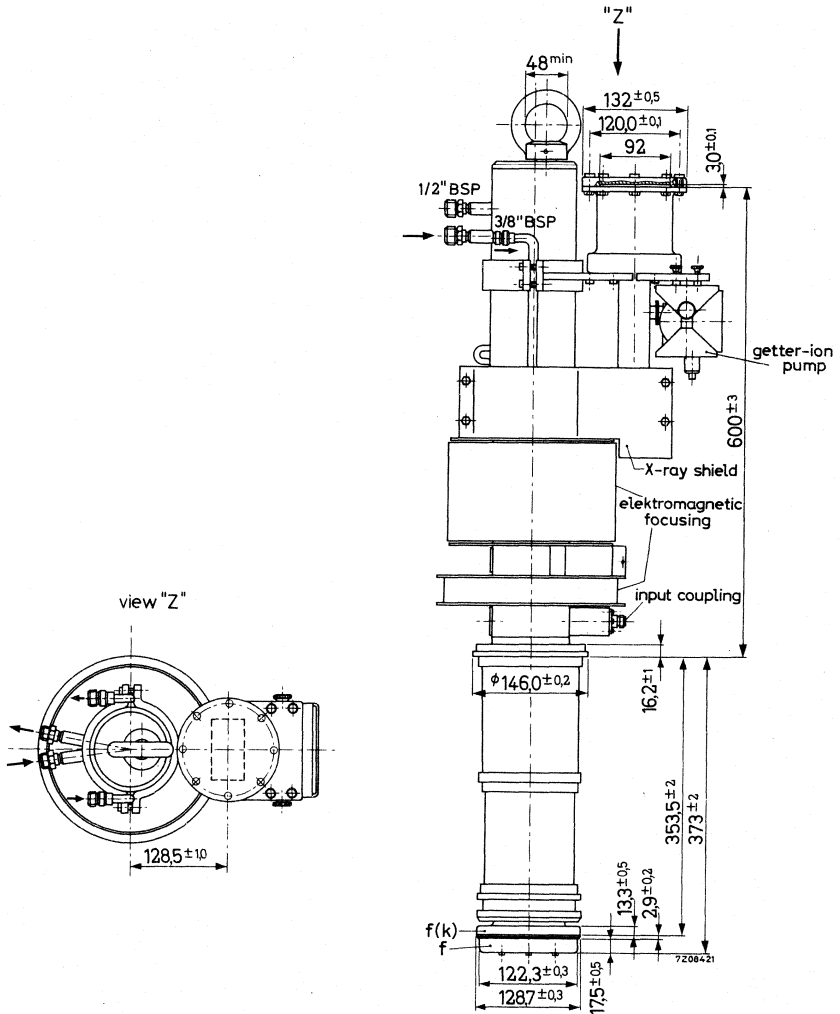

Fig. 1.

**MOUNTING** Vertical.

To be supported from mounting flange with cathode down. Although the collector and output cavity are provided with a lead shield, adequate additional shielding is required for protection against personal injury due to X-ray radiation.

**LIMITING VALUES** (Absolute maximum rating system) for pulsed operation.

notes

All voltages are specified with respect to ground.

Cathode voltage, peak	max.	-220 kV	
Cathode current, peak	max.	120 A	
Beam input power, peak	max.	25 MW	
R.F. input power, peak	max.	10 kW	
R.F. output power, peak	max.	8 MW	
Pulse repetition rate	max.	600 p.p.s.	
Pulse duration	max.	3 $\mu$ s	
Voltage standing-wave ratio of load	max.	1,5	
Focusing magnet voltage	max.	50 V	
Focusing magnet current	max.	32 A	
	min.	24 A	
Pump voltage	max.	4,5 kV	
Pump current	max.	15 mA	
Water outlet temperature	max.	75 °C	

**OPERATING CONDITIONS**

Frequency	2998 MHz	1
Heater current		2
Cathode voltage, peak	-210 kV	3
Cathode current, peak	100 A	
mean	10 mA	
Focusing magnet voltage	40 V	
Focusing magnet current	29 A	4
Pulse repetition rate	50 p.p.s.	5
Pulse duration	2,2 $\mu$ s	
R.F. input power	5 kW	
R.F. output power, peak	6 mW	
mean	0,66 kW	

**Notes**

1. When the klystron has not been in operation for some time, conditioning might be required. This should be done by gradually increasing the cathode voltage until in each step stable operation is obtained. Stored tubes require pumping at intervals of approx. 3 months.
2. To be adjusted at the value marked on each tube.
3. For maintaining a minimum output power of 5 MW during life the cathode voltage may be increased to -215 kV.
4. To be adjusted for max. r.f. output power.
5. Data for operation at p.r.r. higher than 50 p.p.s. on request.

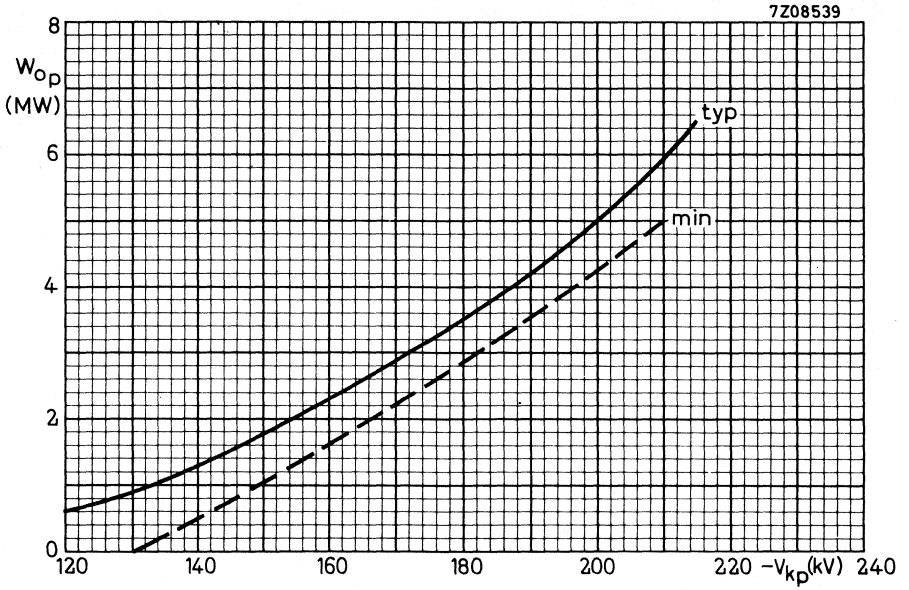

Fig. 2.

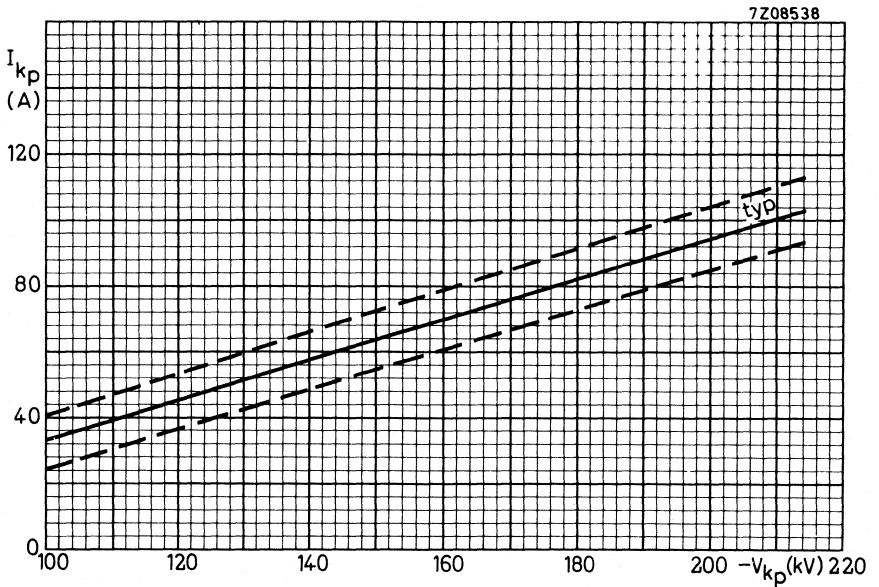

Fig. 3.

## U.H.F. POWER KLYSTRON

U.H.F. TV power klystron in metal-ceramic construction, with four external resonant cavities, integral permanent magnets, and incorporated getter-ion pump. The klystron is intended to be used with depressed collector voltage in 10 kW and 20 kW vision transmitters, in sound transmitters or in high-power transposers in the frequency range 470 to 860 MHz.

### QUICK REFERENCE DATA

Frequency range	470 to 860 MHz
Output power, peak sync	25 kW
Gain	≥ 40 dB
Cooling	forced air

**HEATING:** indirect by d.c.

Cathode	dispenser type		
Heater voltage	$V_f$		8 V
During operation the heater voltage should not fluctuate more than ± 3 %.			
Heater current	$I_f$		≈ 32 (≤ 36) A
The heater current should never exceed a peak value of 65 A.			
Cold heater resistance	$R_{fo}$		≈ 28 mΩ
Waiting time			
a. Heater voltage 8 V	$t_w$	min.	180 s
b. Flash heating 9 V	Detailed information (120 s/9 V)		on request
c. Stand-by 5,5 V	$T_w$	min.	0 s

Valid after a waiting time of at least 8 min (on  $V_f = 5,5V$ ); as soon as the beam voltage is switched on, the heater voltage must be increased to 8 V.

### FOCUSING

The integral temperature-compensated coaxial permanent magnets are pre-adjusted by the tube manufacturer.

### GETTER-ION PUMP SUPPLY

Pump voltage, no load condition	4 kV
Internal resistance	300 kΩ

If it is between 3 kV and 5 kV, the collector to body voltage may be used as the pump supply voltage. In this case the pump anode must be connected to body (earth) via a 300 kΩ series resistor.

### MOUNTING

Mounting position: vertical with collector down.

MASS (net)	approx. 100 kg
------------	----------------

**COOLING**

Cathode socket and accelerating electrode  
 Drift tube 3  
 Drift tube 4  
 Drift tube 5  
 Cavity 3  
 Output cavity 4  
 Collector (60 kW dissipation)

low velocity air flow } 0,5 m<sup>3</sup>/min with reference  
 low velocity air flow } to an area of 100 cm<sup>2</sup>.  
 forced air, 1 m<sup>3</sup>/min, P<sub>i</sub> = 800 Pa  
 forced air, 2 m<sup>3</sup>/min, P<sub>i</sub> = 800 Pa  
 forced air, 1 m<sup>3</sup>/min, P<sub>i</sub> = 800 Pa  
 forced air, 1 m<sup>3</sup>/min, P<sub>i</sub> = 800 Pa  
 forced air, min. 55 m<sup>3</sup>/min,  
 P<sub>i</sub> = 1700 Pa, see also cooling curves, Figs 3 and 4.

**Cooling data, using the trolley TE1081**

Cathode socket, drift tubes, and cavities  
 Collector (60 kW dissipation)

forced air, approx 5 m<sup>3</sup>/min, P<sub>i</sub> = 800 Pa  
 forced air, min 55 m<sup>3</sup>/min.  
 P<sub>i</sub> = 2100 Pa, see cooling curves, Fig. 5

**LIMITING VALUES (Absolute maximum rating system)**

Heater voltage	max.	8,5 V
Cathode to body voltage	max.	-28 kV
Accelerator to body voltage	max.	-28 kV
	min.	0 kV
Collector to body voltage	max.	-5 kV
	min.	-0,5 kV
Focusing electrode to cathode voltage	max.	-600 V
	min.	-100 V
Cathode current	max.	4 A
Accelerator electrode current	max.	1,5 mA
Drift tube current, static	max.	60 mA
dynamic*	max.	200 mA
Collector dissipation	max.	65 kW
Series resistor in accelerator electrode circuit	min.	10 kΩ
Pump voltage, no load condition	max.	5 kV
	min.	3 kV
Pump current	max.	15 mA
VSWR of load at operating frequency	max.	1,5
Temperature of focusing magnets	max.	65 °C
Inlet temperature of cooling air	max.	45 °C

\* A drift tube current cut-out should be provided to protect the klystron. The cut-out should have an automatic action which depends on the drive level.



**ACCESSORIES (standard)**

Frequency range (MHz)	470 to 638	638 to 790	790 to 860
Channel	21 to 41	42 to 60	61 to 68
Stub	TE1089	TE1089	TE1089
Circulator	*	2722 162 01561	2722 162 03261
Cavity 1 Input coupling device	TE1077A TE1083	TE1078A TE1084	TE1078A TE1084
Cavity 2 Load coupling device	TE1077A TE1085	TE1078A TE1086	TE1078A TE1086
Cavity 3 Load coupling device Adaptor flange	TE1077A TE1085 —	TE1078A TE1086 —	TE1078D TE1086 TE1090
Cavity 4 Output coupling device	TE1077D TE1091A	TE1078D TE1092A	TE1078D TE1092A
Trolley	TE1081	TE1081	TE1081
Air duct for cavities	—	TE1115	TE1116
Air duct for drift tube 3	TE1117	TE1117	TE1117
Air duct for drift tube 4	TE1118	TE1118	TE1118
Air duct for drift tube 5	TE1119	TE1119	TE1119
Magnet for ion pump	TE1053A	TE1053A	TE1053A
Connectors			
Heater	40649	40649	40649
Heater/cathode	40649	40649	40649
Focusing electrode	40634	40634	40634
Accelerating electrode	40634	40634	40634
Collector	40649	40649	40649
Ion pump	40634	40634	40634
Earth	40649	40649	40649

**Special parts**

Load coupling unit mating TE1077D (instead of TE1091A)	TE1087
Load coupling unit mating TE1078D (instead of TE1092A)	TE1088
Plug connection mating TE1091A	TE1091B
Plug connection mating TE1092A	TE1092B
Tube extractor	TE1113

\* For frequency range 470 to 604 MHz (channels 21 to 37): 2722 162 01551.  
 For frequency range 604 to 638 MHz (channels 38 to 41): 2722 162 01561.

MECHANICAL DATA

Dimensions in mm

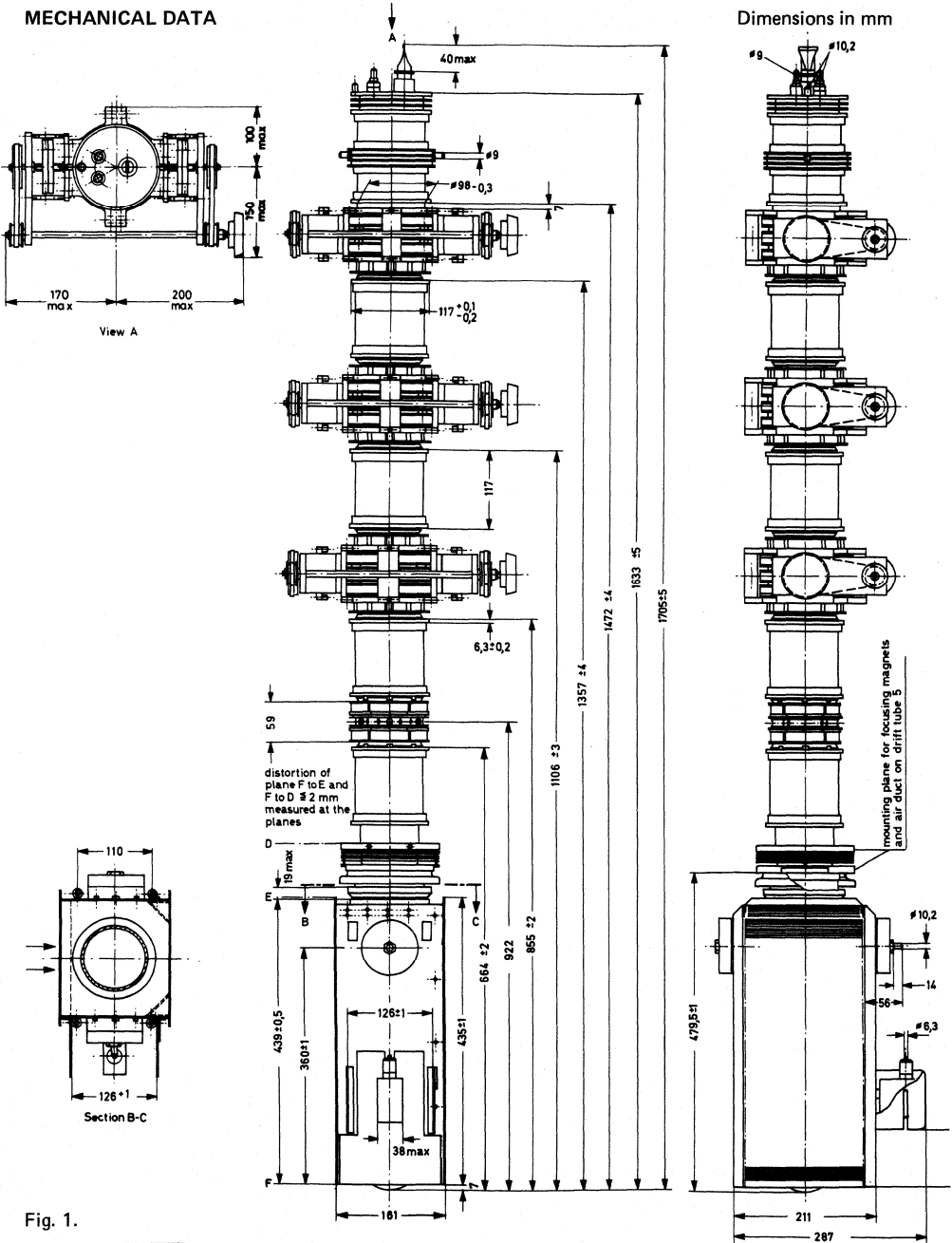

Fig. 1.



**TYPICAL OPERATION** (With stated accessories)

As a **20 kW vision transmitter** in accordance with CCIR-G standard

*Operating conditions*

Frequency range	470 to 638	638 to 790	790 to 860	MHz
Channel	21 to 41	42 to 60	61 to 68	
Cathode to collector voltage	-16,5 -20,0	-20,0	-20,0	kV 2
Cathode current	3,6 3,0	3,0	3,1	A
Collector to body voltage	-4,0 -4,0	-4,0	-4,5	kV
Body current (black level)	100 70	70	70	mA
Accelerating electrode to body voltage	0 ≈ -6	≈ -6	≈ -6	kV
D.C. input power	59 60	60	62	kW
Focusing electrode to cathode voltage	-100 to -600	-100 to -600	-100 to -600	V 3

*Performance*

Output power, peak sync	22			kW
	min.	typ.	max.	
Driving power, peak sync				
in channels 21 to 41			2,5 W	
in channels 42 to 68			1,7 W	
Sync compression			40/25	5
V.S.B. suppression	23	25		dB 6
Noise, with reference to black level	-48	> -50		dB 7
Low-frequency linearity	0,75	0,8		8
Differential gain	0,75	0,85		9
Differential phase		+10/-3	+15/-5 deg	9,10
Variation in response characteristic as a function of power level				
in the double-sideband region		0,25	0,5 dB	11
in the single-sideband region		0,4	0,6 dB	12
Ripple of response characteristic (white level 10/20)			0,3 dB	
Maximum output power		25		kW 13
Efficiency		42		%

Notes see page B47

As a 10 kW vision transmitter in accordance with the CCIR-G standard

notes

*Operating conditions*

	470 to 638		638 to 790	790 to 860	MHz
Frequency range	470 to 638		638 to 790	790 to 860	MHz
Channel	21 to 41		42 to 60	61 to 68	
Cathode to collector voltage	-13,5	-16,0	-16,0	-16,0	kV 2
Cathode current	2,4	2,1	2,1	2,2	A
Collector to body voltage	-4,0	-4,0	-4,0	-4,5	kV
Body current (black level)	70	50	50	50	mA
Acceleration electrode to body voltage	≈ -2,0	≈ -5,5	≈ -5,5	≈ -6,0	kV
D.C. input power	33,0	33,5	33,5	35,0	kW
Focusing electrode to cathode voltage	-100 to -600	-100 to -600	-100 to -600	-100 to -600	V 3

*Performance*

	11			kW
	min.	typ.	max.	
Output power, peak sync				
Driving power, peak sync				
in channels 21 to 41			2,5 W	
in channels 42 to 68			1,7 W	
Sync compression			40/25	5
V.S.B. compression	23	25		dB 6
Noise, with reference to black level	-48	> -50		dB 7
Low-frequency linearity	0,75	0,80		8
Differential gain	0,75	0,85		9
Differential phase		+10/-3	+15/-5 deg	9,10
Variation of response characteristic as a function of power level				
in the double-sideband region		0,25	0,50 dB	11
in the single-sideband region		0,4	0,6 dB	12
Ripple of response characteristic (white level 10/20)			0,3 dB	
Maximum output power		12,5		kW 13
Efficiency		38		%

Notes see page B47.

**TYPICAL OPERATION** (With stated accessories)As a **sound transmitter** in accordance with the CCIR-G standard

For operation in combination with a 22 kW vision stage.

Frequency range	470 to 638				638 to 790		790 to 860 MHz		
Channels	21 to 41				42 to 60		61 to 68		
Cathode to collector voltage	-16,5		-20,0		-20,0		-20,0		kV
Collector to body voltage	-4,0		-4,0		-4,0		-4,5		kV
Focusing electrode to cathode voltage	-100 to -600				-100 to -600				V
Driving power	≤ 0,5				≤ 0,5				W
Accelerating electrode to body voltage	-12,5	-14,5	-16,5	-18,5	-16,5	-18,5	-17,0	-19,0	kV
Cathode current	0,9	0,6	0,8	0,5	0,8	0,8	0,8	0,5	A
Output power	4,4	2,2	4,4	2,2	4,4	2,2	4,4	2,2	kW

14

For operation in combination with an 11 kW vision stage.

Frequency range	470 to 638				638 to 790		790 to 860		
Channels	21 to 41				42 to 60		61 to 68		
Cathode to collector voltage	-13,5		-16,0		-16,0		-16,0		kV
Collector to body voltage	-4,0		-4,0		-4,0		-4,5		kV
Focusing electrode to cathode voltage	-100 to -600				-100 to -600				V
Driving power	≤ 0,5				≤ 0,5				W
Accelerating electrode to body voltage	-11,5	-13,0	-14,5	-16,0	-14,5	-16,0	-15,0	-16,5	kV
Cathode current	0,6	0,4	0,5	0,3	0,5	0,3	0,5	0,3	A
Output power	2,2	1,1	2,2	1,1	2,2	1,1	2,2	1,1	kW

14

Notes see page B47.

Notes

1. In case of failure the beam voltage must be switched-off and made to drop below 5% of its nominal value within 500 ms after occurrence of this failure.
2. Fluctuations up to  $\pm 3\%$  will not damage the tube; to obtain a good signal transfer quality the beam voltage should not vary more than  $\pm 1\%$ .
3. To be adjusted for the stated cathode current.
4. The signal transfer quality is measured with matched load ( $VSWR \leq 1,05$ ).
5. Calculated from  $(1 - V_{black}/V_{sync})_{in} / (1 - V_{black}/V_{sync})_{out}$
6. Measured with 10 to 75% modulation without compensation; V.S.B. filter between driving stage and klystron.
7. Produced by the klystron itself; without hum from power supplies.
8. Measured with a staircase signal of 10 to 75% of the peak sync value.
9. Measured with a sawtooth voltage with an amplitude between 15 and 80% of the peak sync value on which is superimposed a 4,43 MHz sinewave with a 10% peak to peak value.
10. Phase difference to burst signal.
11. With respect to  $\pm 0,5$  MHz around the carrier frequency.
12. With respect to indicated tolerance range
13. With increased driving power under the given operating conditions, without guarantee for signal transfer quality.
14. Cathode current adjusted by accelerating electrode voltage (coarse), and focusing electrode voltage (fine).

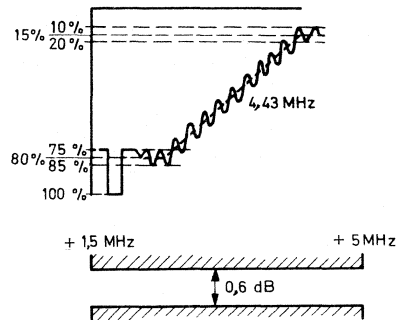

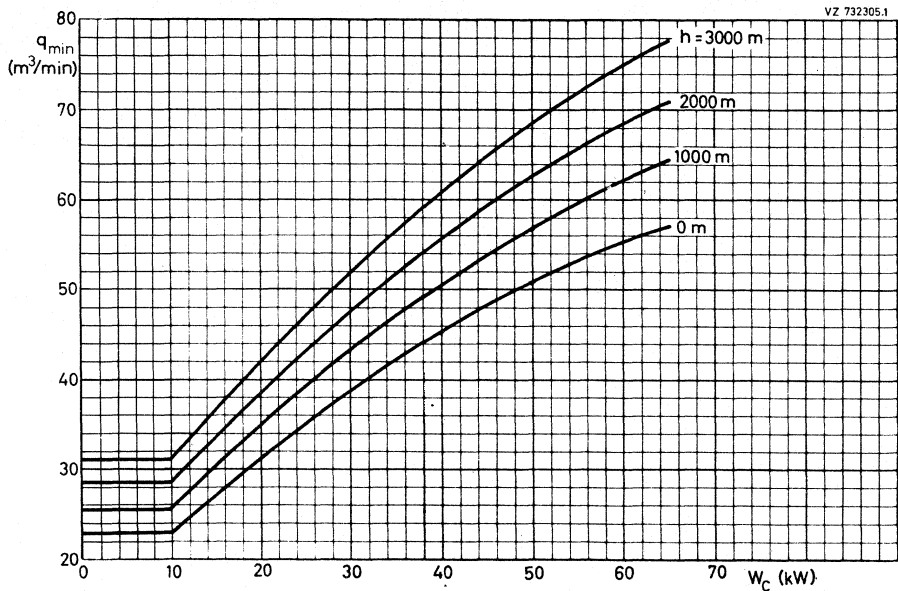

Fig. 3.

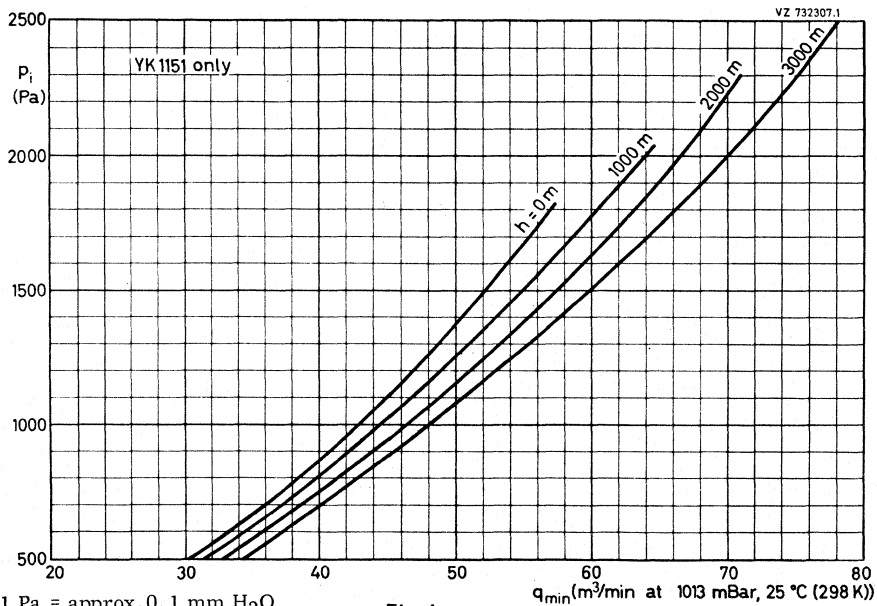

Fig. 4.

The above curves apply to air inlet temperatures up to 45 °C.



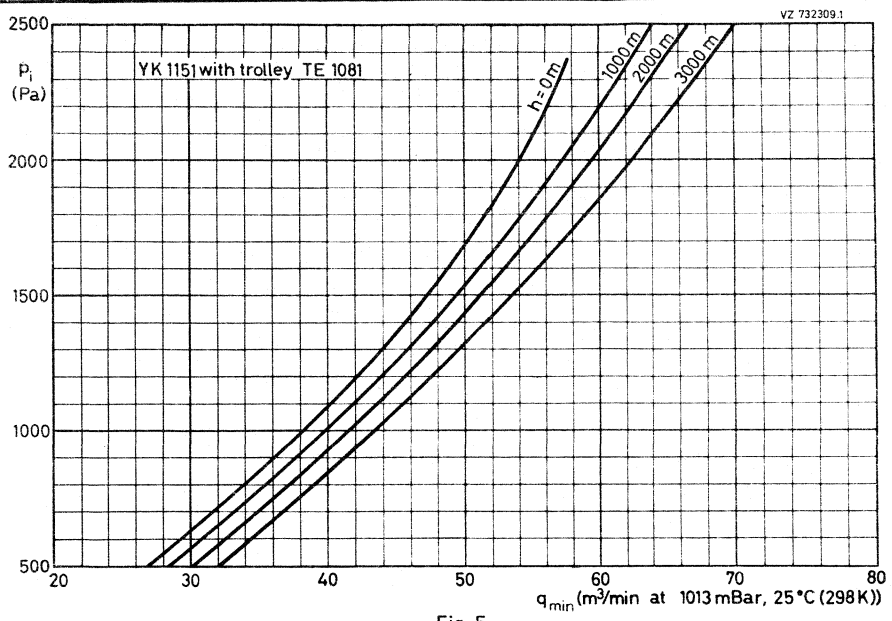

Fig. 5.





## U.H.F. POWER KLYSTRONS

Optionally vapour, vapour condensation, or water-cooled power klystrons in metal-ceramic construction for 40 kW vision transmitters and sound transmitters in the U.H.F. bands IV/V. The tubes have four external cavities, electromagnetic focusing and a high stability dispenser-type cathode.

### QUICK REFERENCE DATA

Frequency range	
YK1190	470 to 610 MHz
YK1191	590 to 720 MHz
YK1192	710 to 860 MHz
Cooling	vapour, vapour condensation, or water

**HEATING:** indirect by d.c.

notes: see page B59

Cathode	dispenser type	
Heater voltage	$V_f$	8,5 V*
Heater current	$I_f$	≈ 22 to 27 A note 1
Cold heater resistance	$R_{fo}$	≈ 30 mΩ
Waiting time		note 2
from cold, $V_f = 0$ V	$t_w$	min. 300 s
from black heat, $V_f = 6$ V	$t_w$	min. 0 s

**FOCUSING:** electromagnetic

Focusing coil current	9 to 12 A
Resistance of focusing coils	
cold (20 °C)	7,2 to 9,5 Ω
operating at an ambient temperature of 20 °C	≤ 11 Ω

### BEAM CONTROL

The accelerator electrode voltage allows adjustment of the beam current between 0 and 100 %.

### GETTER-ION PUMP SUPPLY

note 3

Pump voltage, no-load condition	3 to 4 kV
Internal resistance of supply	300 kΩ

\* During operation the heater voltage may not fluctuate more than ± 3%.

YK1190  
YK1191  
YK1192

MECHANICAL DATA YK1190

Dimensions in mm

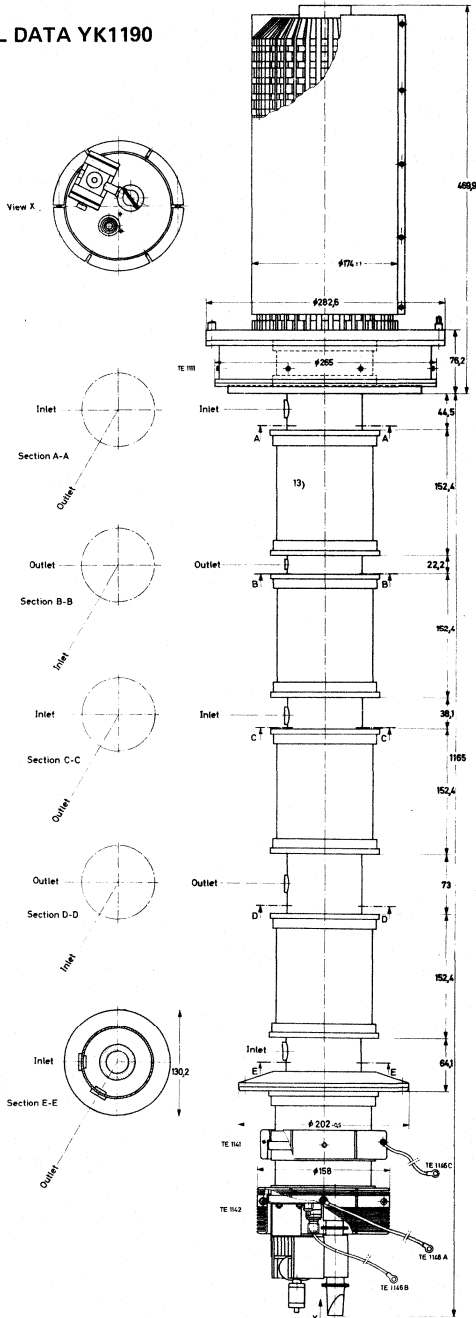

Fig. 1

YK1191, YK1192

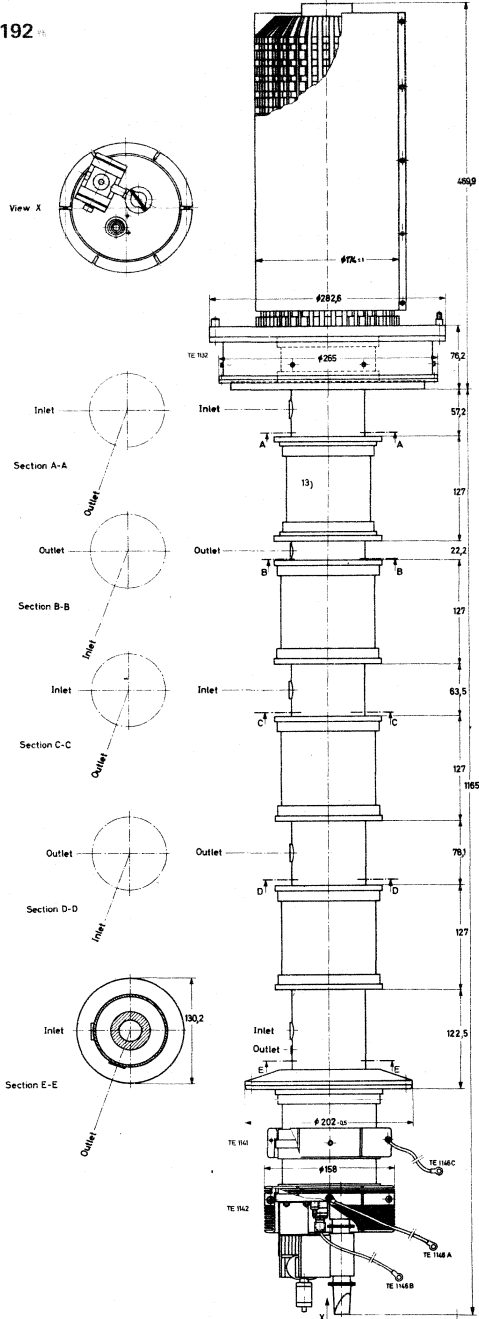

Fig. 2

## COOLING

Cathode socket and  
accelerator electrode

air ;  $q \approx 0,15 \text{ m}^3/\text{min}$ ,  $t_i$  max.  $40 \text{ }^\circ\text{C}$

Collector

vapour (with boiler TE1110), note 4  
volume of water converted to steam:  $27 \text{ cm}^3/\text{min}$   
per kW collector dissipation resulting in  $43 \text{ l}/\text{min}$   
steam per kW collector dissipation  
water or vapour condensation (with cooler TE1194)  
 $q = 35 \text{ to } 60 \text{ l}/\text{min}$ ,  $t_o$  max.  $80 \text{ }^\circ\text{C}$

Drift tubes

water; rate of flow to drift tubes and collector  
connected in series  $q = 9 \text{ l}/\text{min}$ ,  $t_i$  max.  $80 \text{ }^\circ\text{C}$ ,  
 $p_i = 200 \text{ kPa}$  ( $\approx 2 \text{ at}$ )

Cavities 3 and 4

forced air;  $q = 1,5 \text{ m}^3/\text{min}$ ,  $p_i = 250 \text{ Pa}$  ( $\approx 25 \text{ mm}$   
 $\text{H}_2\text{O}$ ),  $t_i$  max.  $45 \text{ }^\circ\text{C}$

## MASS (net)

Tube

approx.  $80 \text{ kg}$

Cavities

approx.  $45 \text{ kg}$

Magnet frame with coils and boiler or cooler

approx.  $850 \text{ kg}$

## MOUNTING

Mounting position: vertical with collector up.

To remove the tube from the magnet frame a total free height of  $3,5 \text{ m}$ , excluding hoist, is required.  
For detailed mounting and tuning instructions see klystron instruction manual, delivered with each tube.

## ACCESSORIES (note 5)

Each tube is delivered with the following factory fitted accessories:

Collector radiation suppressor

Accelerator electrode ring

Cathode ring

Heater/cathode connection cable (red)

Heater connection cable (blue)

Accelerator electrode connection cable (yellow)

Set of sealing rings

ACCESSORIES (continued):	YK1190	YK1191	YK1192
<b>A. Accessories to be ordered separately when replacing equivalent other brand types</b>			
Magnet flux ring	TE1138	TE1138	—
Spark gap	TE1140	TE1140	—
<b>B. Accessories required for first equipment</b>			
Magnet flux ring	TE1138	TE1138	TE1138
Spark gap	TE1140	TE1140	TE1140
Extension pipes for drift tubes	6x TE1133A 2x TE1133B	6x TE1133A 2x TE1133B	6x TE1133A 2x TE1133B
Water interconnecting pipes between drift tubes			
T <sub>1</sub> - T <sub>2</sub>	TE1134A	TE1135A	TE1135A
T <sub>2</sub> - T <sub>3</sub>	TE1134B	TE1135B	TE1135B
T <sub>3</sub> - T <sub>4</sub>	TE1134C	TE1135C	TE1135C
T <sub>4</sub> - T <sub>5</sub>	TE1134D	TE1135D	TE1135D
Flexible water pipes			
between tube and boiler for vapour cooling	TE1145A	TE1145A	TE1145A
between frame and tube	TE1145B	TE1145B	TE1145B
tube outlet for water cooling	TE1145C	TE1145C	TE1145C
Boiler for vapour cooling or Cooler for water cooling	TE1110 TE1194	TE1110 TE1194	TE1110 TE1194
Cavities	3x TE1121A 1x TE1121D	3x TE1098A 1x TE1098D	3x TE1191A 1x TE1191B
Input coupler	TE1122A	TE1102	TE1197
Load coupler for cav. 2 and 3	2x TE1122B	2x TE1102	2x TE1197
Output coupler for cavity 4	TE1123	TE1105	TE1196
Arc detector	TE1107	TE1107	TE1107
Magnet frame with coils	TE1108	TE1108	TE1108
Tool set	TE1137	TE1137	TE1137
<b>Spare and optional parts</b>			
Collector radiation suppressor	TE1111	TE1132	TE1195
Accelerator electrode ring	TE1141	TE1141	TE1141
Cathode ring	TE1142	TE1142	TE1142
Heater/cathode connection cable	TE1146A	TE1146A	TE1146A
Heater connection cable	TE1146B	TE1146B	TE1146B
Accel. electr. connection cable	TE1146C	TE1146C	TE1146C
Set of sealing rings	TE1147	TE1147	TE1147
Water protection shield	TE1139	TE1139	TE1139
Recommended circulators			
470 to 600 MHz	2722 162 01551 (T100/IV-N)		
600 to 800 MHz	2722 162 01561 (T100/V-N)		
790 to 1000 MHz	2722 162 03261 (T100/V-3-N)		

YK1190  
YK1191  
YK1192

**LIMITING VALUES** (Absolute maximum rating system)

Heater voltage	max.	9,5	V	
Beam voltage	max.	-23	-26 kV	note 6
Cold cathode voltage	max.	-27	-30 kV	note 6
Beam current	max.	7	A	
Body current	max.	150	mA	
Accelerator electrode current	max.	6	mA	note 7
Collector dissipation	max.	150	kW	
Load v.s.w.r.	max.	1,5		
Temperature of tube envelope	max.	175	°C	





**TYPICAL OPERATING CONDITIONS: YK1190/YK1191**

**As 40 kW vision transmitter (CCIR-G standard)**

	gain-tuned operation	efficiency-tuned operation (examples)				
		45	45	45	45	
Output power, peak sync.	45	45	45	45	kW	
Beam voltage	-22	-20,5	-22	-25,5	kV	note 6
Beam current	6,3	5,7	4,8	3,8	A	note 8
Accelerator to cathode voltage	22	20,5	18	16	kV	
Body current						
without drive	15	15	15	15	mA	
at 45 kW peak sync., black level	30	40	40	40	mA	
Focusing coil current	10,5	10,5	10,0	9,5	A	
Drive power, peak sync.						
YK1190 - channel 21	2	10	6	6	W	note 9
channel 38	1,5	7	4	4	W	note 9
YK1191 - channel 37	1,5	7	4	4	W	note 9
channel 51	1	5	3	3	W	note 9
Bandwidth at -1 dB points	8	8	8	8	MHz	note 10
Differential gain	80	75	70	70	%	note 11
Differential phase	6	7	10	10	deg	note 11
Linearity	70	65	60	60	%	note 12
Operating efficiency	32	38,5	42,5	46,5	%	
Saturation output power	55	60	46,5	46,5	kW	
Saturation efficiency	40	43	44	48	%	

**As 4 kW/8 kW sound transmitter (CCIR-G standard)**

Output power	4,5	9	4,5	9	4,5	9	kW	
Beam voltage	-20,5	-20,5	-22	-22	-25,5	-25,5	kV	note 6
Beam current	1,25	1,5	1,15	1,4	1,0	1,3	A	
Accelerator cathode voltage	≈ 7,5	≈ 8,5	≈ 7	≈ 8	≈ 6,5	≈ 8	kV	note 14
Focusing coil current	9						A	
Drive power	1,5						W	note 9
Bandwidth at -1 dB points	1						MHz	

**TYPICAL OPERATING CONDITIONS: YK1192**

**As 40 kW vision transmitter (CCIR-G standard)**

Output power, peak sync.	45	45	kW	
Beam voltage	-23	-25,5	kV	note 6
Beam current	4,6	3,9	A	note 8
Accelerator to cathode voltage	18	16	kV	
Body current				
without drive	15	15	mA	
at 45 kW peak sync., black level	40	40	mA	
Focusing coil current	10	10	A	
Drive power, peak sync.	2	2	W	note 9
Bandwidth at -1 dB points	8	8	MHz	note 10
Differential gain	70	70	%	note 11
Differential phase	10	10	deg	note 11
Linearity	60	60	%	note 12
Operating efficiency	42,5	45	%	
Saturation output power	46,5	46,5	kW	
Saturation efficiency	44	46,5	%	

**As 4 kW/8 kW sound transmitter (CCIR-G standard)**

Output power	4,5	9	4,5	9	kW	
Beam voltage	-23	-23	-25,5	-25,5	kV	note 6
Beam current	1,1	1,3	1,0	1,3	A	
Accelerator to cathode voltage	≈ 7	≈ 8	≈ 6,5	≈ 8	kV	note 14
Focusing coil current			9		A	
Drive power			1,5		W	note 9
Bandwidth at -1 dB points			1		MHz	

For detailed mounting and tuning instructions  
see klystron instruction manual,  
delivered with each tube.

## Notes

1. When switching on the heater voltage, the heater current must never exceed a peak value of 65 A.
2. In cases of a mains failure an interruption up to 30 s can be tolerated without new preheating. After min. 10 minutes of stand-by heating time at 6,0 V, the beam current may be switched on; the heater voltage must be increased to its nominal value of 8,5 V simultaneously. Operation under stand-by conditions is restricted to continuous periods of 2 weeks at a time. Stand-by periods should be separated by similar periods of rest or full operation.
3. To ensure that the klystron is ready for immediate operation the ion getter pump should be operated at least every 6 months during storage, 3 months being recommended. For details see klystron instruction manual.
4. In order to avoid corrosion of the cooling system, pure deionised water must be used as the coolant (resistivity min. 10 k $\Omega$ .cm).
5. Correct operation of the tube can be guaranteed only if a set of accessories, approved by the tube manufacturer, is used. The operating tube generates X-rays which can penetrate the ceramic parts of the tube envelope. In order to reduce the radiation at any accessible points to an officially admissible, non-dangerous, level the tube must be shielded and any possible radiation path must be blocked by at least 1 mm of brass or an equivalent portion of non-magnetic X-ray absorbing material. The proper use of our accessory parts will provide the necessary shielding.
6. Pertaining to the highest value: special high-voltage protection on tube is required. When using this value please contact the tube manufacturer beforehand.
7. The accelerator electrode voltage must not be positive with respect to the body (ground).
8. If the accelerator electrode is connected to the body (ground) via a 10 k $\Omega$  resistor, the beam current is within  $\pm 5\%$  of the value given in the graph of Fig. 3.
9. The drive power is defined as the power delivered to a matched load.
10. Varying the input level between black and white at any sideband frequency within this bandwidth will not cause a variation of the peak sync. output power exceeding 0,5 dB.
11. Measured with a sawtooth signal from black level to peak white occurring at each line and superimposed colour subcarrier with a 10% peak to peak amplitude.
12. Measured with a ten-step staircase signal from black level to peak white occurring at each line.
13. Where the ceramic of the output section is beryllium oxide, this is indicated on the tube. The dust of beryllium oxide is toxic. For the disposal of burnt-out tubes observe government regulations. For adjusting the beam current in sound operation a voltage divider should be dimensioned according to an accelerator electrode current of max. 1,5 mA.

YK1190  
YK1191  
YK1192

7Z67437.1

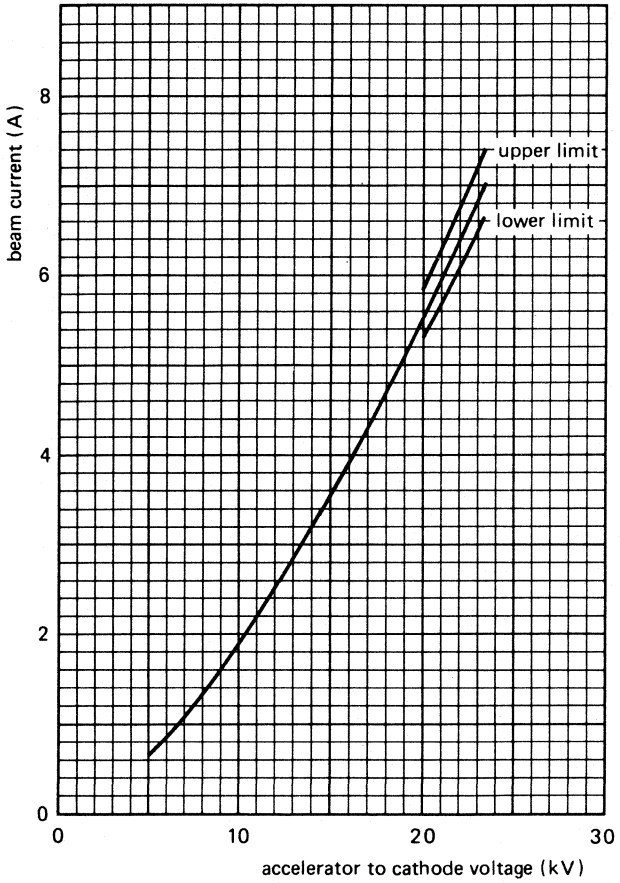

Fig. 3.

## U.H.F. POWER KLYSTRONS

Optionally vapour, vapour condensation, or water-cooled power klystrons in metal-ceramic construction for 55 kW vision transmitters and sound transmitters in the U.H.F. bands IV/V. The tubes have four external cavities, electromagnetic focusing and a high stability dispenser-type cathode.

### QUICK REFERENCE DATA

Frequency range	
YK1195	470 to 610 MHz
YK1196	590 to 720 MHz
YK1197	710 to 860 MHz
Cooling	vapour, vapour condensation, or water

### HEATING: indirect by d.c.

Cathode	dispenser type	notes; see page B69
Heater voltage	$V_f$	8,5 V*
Heater current	$I_f$	≈ 22 to 27 A note 1
Cold heater resistance	$R_{fo}$	≈ 30 mΩ
Waiting time		note 2
from cold, $V_f = 0$ V	$t_w$	min. 300 s
from black heat, $V_f = 6$ V	$t_w$	min. 0 s

### FOCUSING: electromagnetic

Focusing coil current	9 to 12 A
Resistance of focusing coils	
cold (20 °C)	7,2 to 9,5 Ω
operating at an ambient temperature of 20 °C	≤ 11 Ω

### BEAM CONTROL

The accelerator electrode voltage allows adjustment of the beam current between 0 and 100%.

### GETTER-ION PUMP SUPPLY

Pump voltage, no-load condition	3 to 4 kV	note 3
Internal resistance of supply	300 kΩ	

\* During operation the heater voltage may not fluctuate more than ± 3%.

YK1195  
YK1196  
YK1197

MECHANICAL DATA YK1195

Dimensions in mm

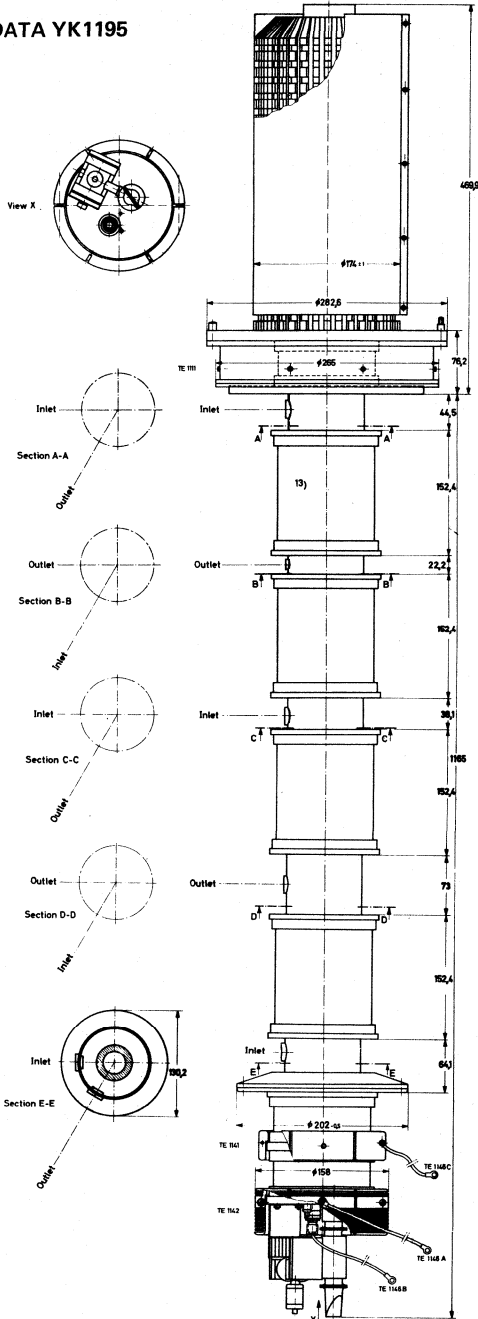

Fig. 1.



## COOLING

Cathode socket and  
accelerator electrode  
Collector

air;  $q \approx 0,15 \text{ m}^3/\text{min}$ ,  $t_j$  max.  $40 \text{ }^\circ\text{C}$   
vapour (with boiler TE1110), note 4  
volume of water converted to steam:  $27 \text{ cm}^3/\text{min}$   
per kW collector dissipation resulting in  $43 \text{ l}/\text{min}$   
steam per kW collector dissipation  
water or vapour condensation (with cooler TE1194)  
 $q = 35 \text{ to } 60 \text{ l}/\text{min}$ ,  $t_o$  max.  $80 \text{ }^\circ\text{C}$

Drift tubes

water; rate of flow to drift tubes and collector  
connected in series  $q \approx 9 \text{ l}/\text{min}$ ,  $t_j$  max.  $80 \text{ }^\circ\text{C}$ ,  
 $p_i = 200 \text{ kPa}$  ( $\approx 2 \text{ at}$ )

Cavities 3 and 4

forced air;  $q = 1,5 \text{ m}^3/\text{min}$ ,  $p_i = 250 \text{ Pa}$  ( $\approx 25 \text{ mm}$   
 $\text{H}_2\text{O}$ ),  $t_j$  max.  $45 \text{ }^\circ\text{C}$

## MASS (net)

Tube	approx. 80 kg
Cavities	approx. 45 kg
Magnet frame with coils and boiler or cooler	approx. 855 kg

## MOUNTING

Mounting position: vertical with collector up

To remove the tube from the magnet frame a total free height of 3,5 m, excluding hoist, is required. For detailed mounting and tuning instructions see klystron instruction manual, delivered with each tube.

## ACCESSORIES (note 5)

Each tube is delivered with the following factory fitted accessories:

- Collector radiation suppressor
- Accelerator electrode ring
- Cathode ring
- Heater/cathode connection cable (red)
- Heater connection cable (blue)
- Accelerator electrode connection cable (yellow)
- Set of sealing rings



ACCESSORIES (continued):	YK1195	YK1196	YK1197
<b>A. Accessories to be ordered separately when replacing equivalent other brand types</b>			
Magnet flux ring	TE1138	TE1138	
Spark gap	TE1140	TE1140	
<b>B. Accessories required for first equipment</b>			
Magnet flux ring	TE1138	TE1138	TE1138
Spark gap	TE1140	TE1140	TE1140
Extension pipes for drift tubes	6x TE1133A 2x TE1133B	6x TE1133A 2x TE1133B	6x TE1133A 2x TE1133B
Water interconnecting pipes between drift tubes			
T <sub>1</sub> - T <sub>2</sub>	TE1134A	TE1135A	TE1135A
T <sub>2</sub> - T <sub>3</sub>	TE1134B	TE1135B	TE1135B
T <sub>3</sub> - T <sub>4</sub>	TE1134C	TE1135C	TE1135C
T <sub>4</sub> - T <sub>5</sub>	TE1134D	TE1135D	TE1135D
Flexible water pipes			
between tube and boiler for vapour cooling	TE1145A	TE1145A	TE1145A
between frame and tube tube outlet for water cooling	TE1145B TE1145C	TE1145B TE1145C	TE1145B TE1145C
Boiler for vapour cooling or Cooler for water cooling	TE1110 TE1194	TE1110 TE1194	TE1110 TE1194
Cavities	3x TE1121A 1x TE1121D	3x TE1098A 1x TE1098D	3x TE1191A 1x TE1191B
Input coupler	TE1122A	TE1102	TE1197
Load coupler for cavities 2 and 3	2x TE1122B	2x TE1102	2x TE1197
Output coupler for cavity 4	TE1123	TE1105	TE1196
Arc detector	TE1107	TE1107	TE1107
Magnet frame with coils	TE1108	TE1108	TE1108
Tool set	TE1137	TE1137	TE1137
<b>Spare and optional parts</b>			
Collector radiation suppressor	TE1111	TE1132	TE1195
Accelerator electrode ring	TE1141	TE1141	TE1141
Cathode ring	TE1142	TE1142	TE1142
Heater/cathode connection cable	TE1146A	TE1146A	TE1146A
Heater connection cable	TE1146B	TE1146B	TE1146B
Accel. electr. connection cable	TE1146C	TE1146C	TE1146C
Set of sealing rings	TE1147	TE1147	TE1147
Water protection shield	TE1139	TE1139	TE1139
Recommended circulators			
470 to 600 MHz	2722 162 01551 (T100/IV-N)		
600 to 800 MHz	2722 162 01561 (T100/V-N)		
790 to 1000 MHz	2722 162 03261 (T100/V-3-N)		

YK1195  
YK1196  
YK1197

**LIMITING VALUES** (Absolute maximum rating system)

Heater voltage	max.	9,5	V	
Beam voltage	max.	-24	-28 kV	note 6
Cold cathode voltage	max.	-27	-30 kV	note 6
Beam current	max.	7	A	
Body current	max.	150	mA	
Accelerator electrode current	max.	6	mA	note 7
Collector dissipation	max.	150	kW	
Load v.s.w.r.	max.	1,5		
Temperature of tube envelope	max.	175	°C	



## TYPICAL OPERATING CONDITIONS: YK1190/YK1191

## As 55 kW vision transmitter (CCIR-G standard)

	YK1195/YK1196		YK1197		
Output power, peak sync.	58	58	58	58 kW	
Beam voltage	-22,5	-26	-23,5	-27 kV	note 6
Beam current	6,4	4,85	5,9	4,9 A	note 8
Accelerator to cathode voltage	22,5	16,5	21	17 kV	
Body current					
without drive	15	15	15	15 mA	
at 58 kW peak sync., black level	40	40	40	40 mA	
Focusing coil current	10,5	10,5	10,5	10,5 A	
Drive power, peak sync.					
YK1195 - channel 21	10	6	-	- W	note 9
channel 38	7	4	-	- W	note 9
YK1196 - channel 37	7	4	-	- W	note 9
channel 51	5	3	-	- W	note 9
YK1197	-	-	2	2 W	note 9
Bandwidth at -1 dB points	8	8	8	8 MHz	note 10
Differential gain	75	70	70	70 %	note 11
Differential phase	6	10	10	10 deg	note 11
Linearity	65	60	60	60 %	note 12
Operating efficiency	40	46	42	44 %	
Saturation output power	63	60	60	60 kW	
Saturation efficiency	44	47,5	43	45 %	
<b>As 11 kW FM sound transmitter</b>					
Output power	12	12	12	12 kW	
Beam voltage	-22,5	-26	-23,5	-27 kV	note 6
Beam current	1,5	1,2	1,5	1,2 A	
Accelerator cathode voltage	8,5	7,5	8,5	7,5 kV	note 14
Focusing coil current	9	9	9	9 A	
Drive power	1,5	1,5	1,5	1,5 W	note 9
Bandwidth at -1 dB points	1	1	1	1 MHz	



7267437.1

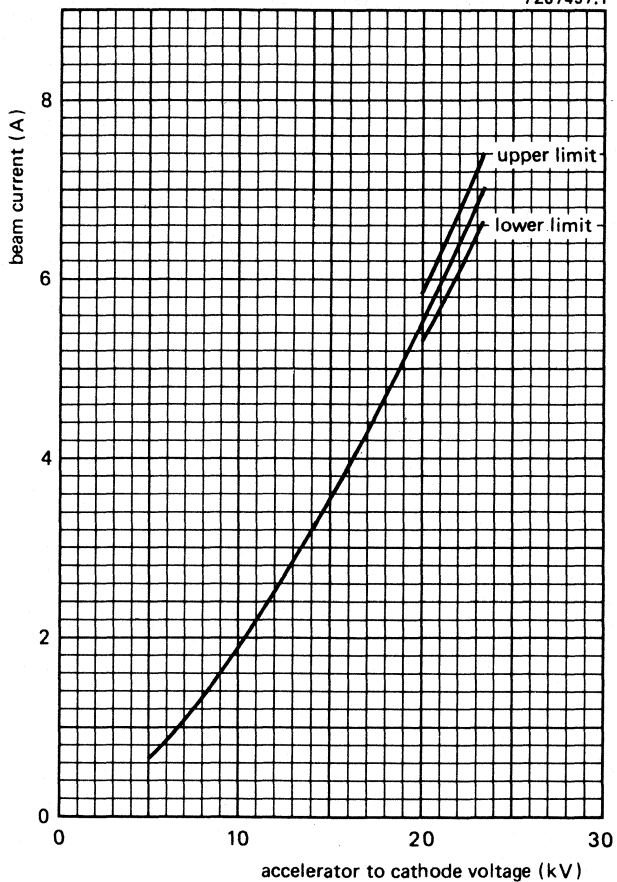

Fig. 3.

## Notes

1. When switching on the heater voltage, the heater current must never exceed a peak value of 65 A.
2. In cases of a mains failure an interruption up to 30 s can be tolerated without new preheating. After min. 10 minutes of stand-by heating time at 6,0 V, the beam current may be switched on; the heater voltage must be increased to its nominal value of 8,5 V simultaneously. Operation under stand-by conditions is restricted to continuous periods of 2 weeks at a time. Stand-by periods should be separated by similar periods of rest or full operation.
3. To ensure that the klystron is ready for immediate operation the getter ion pump should be operated at least every 6 months during storage, 3 months being recommended. For details see klystron instruction manual.
4. In order to avoid corrosion of the cooling system, pure deionised water must be used as the coolant (resistivity min. 10 k $\Omega$ .cm).
5. Correct operation of the tube can be guaranteed only if a set of accessories, approved by the tube manufacturer, is used. The operating tubes generates X-rays which can penetrate the ceramic parts of the tube envelope. In order to reduce the radiation at any accessible points to an officially admissible, non-dangerous level the tube must be shielded and any possible radiation path must be blocked by at least 1 mm of brass or an equivalent portion of non-magnetic X-ray absorbing material. The proper use of our accessory parts will provide the necessary shielding.
6. Pertaining to the highest value: special high-voltage protection on tube is required. When using this value please contact the tube manufacturer beforehand.
7. The accelerator electrode voltage must not be positive with respect to the body (ground).
8. If the accelerator electrode is connected to the body (ground) via a 10 k $\Omega$  resistor, the beam current is within  $\pm 5\%$  of the value given in the graph of Fig. 3.
9. The drive power is defined as the power delivered to a matched load.
10. Varying the input level between black and white at any sideband frequency within this bandwidth will not cause a variation of the peak sync. output power exceeding 0,5 dB.
11. Measured with a sawtooth signal from black level to peak white occurring at each line and superimposed colour subcarrier with a 10% peak to peak amplitude.
12. Measured with a ten-step staircase signal from black level to peak white occurring at each line.
13. Where the ceramic of the output section is beryllium oxide, this is indicated on the tube. The dust of beryllium oxide is toxic. For the disposal of burnt-out tubes observe government regulations.
14. For adjusting the beam current in sound operation a voltage divider should be dimensioned according to an accelerator electrode current of max. 1,5 mA.





## U.H.F. POWER KLYSTRON

Optionally vapour, vapour condensation, or water-cooled power klystron in metal-ceramic construction for 58 kW CW amplifiers. The tube has four external cavities, electromagnetic focusing and a high stability dispenser-type cathode.

### QUICK REFERENCE DATA

Frequency range	800 MHz		
Cooling	vapour, vapour condensation, or water		
<b>HEATING:</b> indirect by d.c.	notes: see page B77		
Cathode	dispenser type		
Heater voltage	$V_f$	8,5 V*	
Heater current	$I_f \approx$	22 to 27 A	note 1
Cold heater resistance	$R_{fo} \approx$	30 m $\Omega$	
Waiting time			note 2
from cold, $V_f = 0$ V	$t_w$ min.	300 s	
from black heat, $V_f = 6$ V	$t_w$ min.	0 s	
<b>FOCUSING:</b> electromagnetic			
Focusing coil current	9 to 12 A		
Resistance of focusing coils			
cold (20 °C)		7,2 to 9,5 $\Omega$	
operating at an ambient temperature of 20 °C	$\leq$	11 $\Omega$	

### BEAM CONTROL

The accelerator electrode voltage allows adjustment of the beam current between 0 and 100%.

### GETTER-ION PUMP SUPPLY

Pump voltage, no-load condition	3 to 4 kV	note 3
Internal resistance of supply	300 k $\Omega$	

\* During operation the heater voltage may not fluctuate more than  $\pm 3\%$ .

MECHANICAL DATA

Dimensions in mm

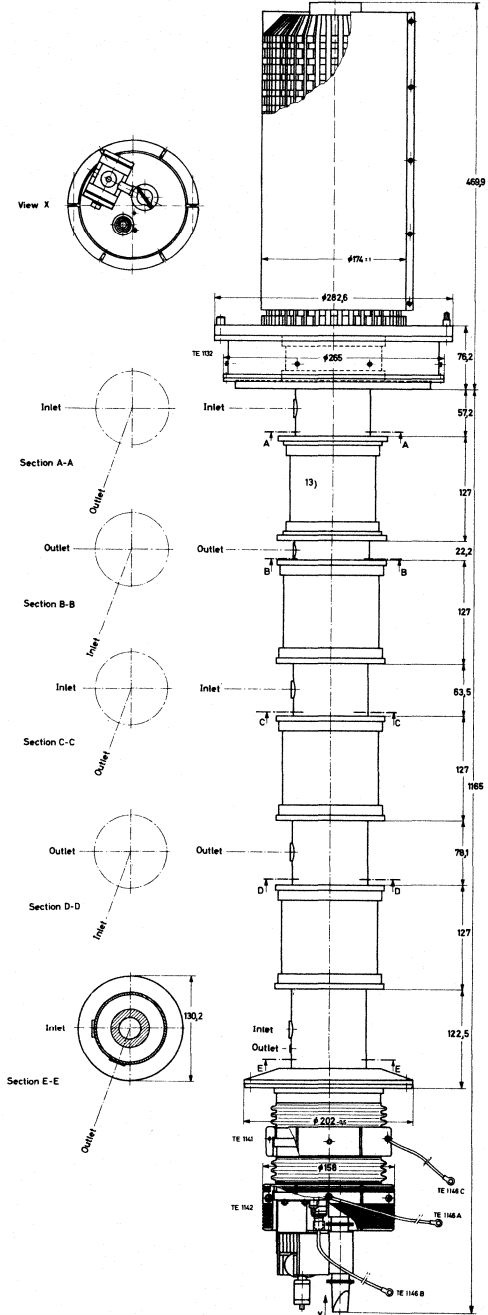

Fig. 1.



**COOLING**

Cathode socket and  
accelerator electrode

air;  $q \approx 0,15 \text{ m}^3/\text{min}$ ,  $t_i$  max.  $45 \text{ }^\circ\text{C}$

Collector

vapour (with boiler TE1110), note 4 volume of  
volume of water converted to steam:  $27 \text{ cm}^3/\text{min}$   
per kW collector dissipation resulting in  $43 \text{ l}/\text{min}$   
steam per kW collector dissipation  
water or vapour condensation (with cooler TE1194)  
 $q = 35 \text{ to } 60 \text{ l}/\text{min}$ ,  $t_o$  max.  $80 \text{ }^\circ\text{C}$

Drift tubes

water; rate of flow to drift tubes and collector  
connected in series  $q \approx 9 \text{ l}/\text{min}$ ,  $t_i$  max.  $80 \text{ }^\circ\text{C}$ ,  
 $p_i = 200 \text{ kPa}$  ( $\approx 2 \text{ at}$ )

Cavities 3 and 4

forced air;  $q = 1,5 \text{ m}^3/\text{min}$ ,  $p_i = 250 \text{ Pa}$  ( $\approx 25 \text{ mm}$   
 $\text{H}_2\text{O}$ ),  $t_i$  max.  $45 \text{ }^\circ\text{C}$

**MASS (net)**

Tube

approx. 80 kg

Cavities

approx. 45 kg

Magnet frame with coils and boiler or cooler

approx. 855 kg

**MOUNTING**

Mounting position: vertical with collector up

To remove the tube from the magnet frame a total free height of 3,5 m, excluding hoist, is required.  
For detailed mounting and tuning instructions see klystron instruction manual, delivered with each  
tube.



**ACCESSORIES**

Set of sealing rings	TE1147
Collector radiation suppressor (factory fitted)	TE1195
Accelerator electrode ring (factory fitted)	TE1141
Cathode ring (factory fitted)	TE1142
Water interconnecting pipes between drift tubes	
T <sub>1</sub> - T <sub>2</sub>	TE1135A
T <sub>2</sub> - T <sub>3</sub>	TE1135B
T <sub>3</sub> - T <sub>4</sub>	TE1135C
T <sub>4</sub> - T <sub>5</sub>	TE1135D
Extension pipes for drift tubes	6 x TE1133A 2 x TE1133B
Flexible water pipes	for vapour cooling      for water cooling
between tube and boiler	TE1145A                      -
between frame and tube tube outlet	TE1145B                      TE1145B -                      TE1145C
Boiler for vapour cooling or Cooler for water cooling	TE1110                      -                      TE1194
Magnet flux ring	TE1138
Water protection shield	TE1139
Spark gap	TE1140
Heater/cathode connection cable (red)	TE1146A
Heater connection cable (blue)	TE1146B
Accelerator electrode connection cable (yellow)	TE1146C
Cavities	3 x TE1191A 1 x TE1191B
Input coupler	TE1102
Load coupler for cavities 2 and 3	2 x TE1102
Blind flanges	3 x TE1157
Output coupler for cavity 4	TE1192
Arc detector	TE1107
Magnet frame with coils	TE1193
Tool set	TE1137
Recommended circulator	2722 162 01561 (T100/V-N)



**LIMITING VALUES** (Absolute maximum rating system)

Heater voltage	max.	9,5 V	
Cathode voltage	max.	-28 kV	
Cold cathode voltage	max.	-30 kV	
Cathode current	max.	7 A	
Drift tube current	max.	60 mA	
Accelerator electrode current	max.	6 mA	note 5
Collector dissipation	max.	150 kW	
Load v.s.w.r.	max.	1,5	
Temperature of tube envelope	max.	175 °C	

**TYPICAL OPERATING CONDITIONS**

As 58 kW CW amplifier

Output power		58 kW	
Cathode voltage		-27 kV	
Cathode current		5 A	note 6
Accelerator to cathode voltage	≈	17,5 kV	
Drift tube current			
without drive		10 mA	
at 58 kW		20 mA	
Focusing coil current	≈	10 A	
Drive power, at 800 MHz	≈	2 W	note 7
Bandwidth at -1 dB points	≈	5 MHz	
Operating efficiency	∇	43 %	



7Z67437.1

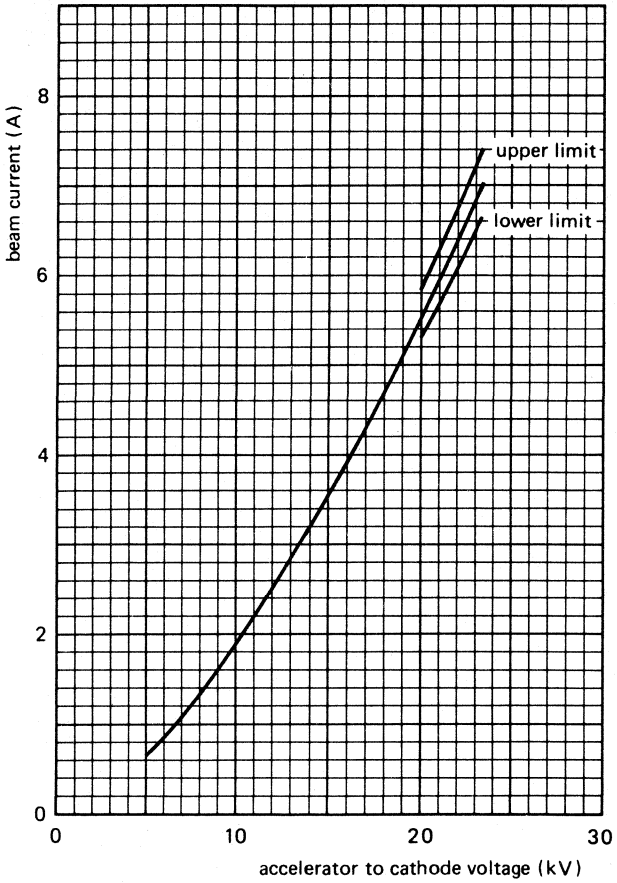

Fig. 2.

**WARNING - Health hazard****1. X-radiation**

Correct operation of the tube can be guaranteed only if a set of accessories, approved by the tube manufacturer, is used. The operating tube generates X-rays which can penetrate the ceramic parts of the tube envelope. In order to reduce the radiation at any accessible points to an officially admissible, non-dangerous, level the tube must be shielded and any possible radiation path must be blocked by at least 1 mm of brass or an equivalent portion of non-magnetic X-ray absorbing material. The proper use of our accessory parts will provide the necessary shielding.

**2. R.F. radiation**

R.F. power may be emitted not only through the normal output coupling but also through other apertures (e.g. r.f. leaks). This r.f. power may be sufficiently intense to cause danger to the human body, particularly to the eyes. Such radiation may be increased if the tube is functioning incorrectly.

**3. Beryllia ceramic**

The ceramic of the output section is beryllium oxide, the dust of which is toxic. For the disposal of burnt-out tubes government regulations must be observed.

**Notes**

1. When switching on the heater voltage, the heater current must never exceed a peak value of 65 A.
2. In cases of a mains failure an interruption up to 30 s can be tolerated without new preheating. After min. 10 minutes of stand-by heating time at 6,0 V, the beam current may be switched on; the heater voltage must be increased to its nominal value of 8,5 V simultaneously. Operation under stand-by conditions is restricted to continuous periods of 2 weeks at a time. Stand-by periods should be separated by similar periods of rest or full operation.
3. To ensure that the klystron is ready for immediate operation the ion getter pump should be operated at least every 6 months during storage, 3 months being recommended. For details see klystron instruction manual.
4. In order to avoid corrosion of the cooling system, pure deionized water must be used as the coolant (resistivity min. 10 k $\Omega$ .cm).
5. The accelerator electrode voltage must not be positive with respect to the body (ground).
6. If the accelerator electrode is connected to the body (ground) via a 10 k $\Omega$  resistor, the cathode current is within  $\pm 5\%$  of the value given in the graph of Fig. 2.
7. The drive power is defined as the power delivered to a matched load.





## S.H.F. POWER KLYSTRON

Forced-air cooled power amplifier klystron in metal-ceramic construction for the frequency band of 11,8 to 12,2 GHz. The tube has internal resonant cavities, beam focusing by means of permanent magnets, and an integral getter-ion pump. The YK1210 is intended to be used in vision and sound transmitters, and transposers. It may be operated with or without depressed collector voltage.

## QUICK REFERENCE DATA

Frequency range	11,8 to 12,2 GHz
Output power as vision transmitter	1,15 kW
Gain	50 dB
Cooling	forced air

## HEATING: indirect by d.c.

Cathode	dispenser type
Heater voltage	$V_f$ 5 to 6 V
Heater current	$I_f$ 4 ( $\leq$ 5) A
Heater peak starting current	$I_{fp}$ max 8 A
Cold heater resistance	$R_{fo}$ $\approx$ 20 m $\Omega$
Waiting time	$t_w$ min 120 s

## COOLING

Cathode socket and accelerating electrode	low-velocity air flow 0,5 m <sup>3</sup> /min, 100 cm <sup>2</sup>
Body	forced air, $\approx$ 0,5 m <sup>3</sup> /min $p_i \leq 1000$ Pa
Collector	forced air, $\approx$ 6 m <sup>3</sup> /min $p_i \leq 1000$ Pa

## GETTER-ION PUMP SUPPLY

Pump voltage, no-load condition	3 kV
Internal resistance of supply	300 k $\Omega$

## MOUNTING

Vertical

Forces on klystron terminals max 10 N. Bending moment max 10 Nm.

To maintain correct focusing, the magnetic system should not be closer than 150 mm to external ferromagnetic materials, and no closer than 300 mm to external magnets.





**LIMITING VALUES** (Absolute maximum rating system)

Collector to cathode voltage	max.	15 kV
Body to collector voltage	max.	4 kV
Body to accelerator voltage	max.	15 kV
Accelerator to cathode voltage	max.	10 kV
	min.	7,5 kV
Cathode current	max.	650 mA
Collector dissipation	max.	7,5 kW
Drift tube current, static, set value	max.	10 mA
<b>As vision transmitter at <math>W_{0\text{ sync}} = 1\text{ kW}</math></b>		
dynamic, without depressed collector voltage	max.	30 mA
dynamic, with depressed collector voltage	max.	60 mA
<b>as transposer at <math>W_{0\text{ sync}} = 210\text{ W}</math></b>		
dynamic, without depressed collector voltage	max.	20 mA
dynamic, with depressed collector voltage		
current cut-out region		20 to 50 mA
measuring range	max.	60 mA
Getter-ion pump voltage	max.	4 kV
	min.	2,5 kV
Pump current	max.	15 mA
Internal resistance of the pump supply	min.	300 k $\Omega$
Accelerator current	max.	-0,2 to +2 mA
Series resistor in accelerator circuit	min.	10 k $\Omega$
Temperature of focusing magnets	max.	55 °C
Inlet temperature of cooling air	max.	45 °C
	min.	5 °C



**TYPICAL OPERATION**

Frequency range	11,8 to 12,2	GHz
Bandwidth (−1 dB)	≥ 12	MHz
Power gain	50 (≥ 49)	dB

without depressed collector voltage	with depressed collector voltage
-------------------------------------	----------------------------------

**As vision transmitter**

Collector to cathode voltage	10,5	8,5	kV
Body to collector voltage	0	2	kV
Cathode current	0,4	0,4	A
Output power, sync	1,15	1,15	kW

**As sound transmitter**

Collector to cathode voltage	10,5	8,5	kV
Body to collector voltage	0	2	kV
Cathode current	0,4	0,4	A
Output power	1,05	1,05	kW

**As transposer ( $W_0$  nom 100 W)**

Collector to cathode voltage	10,5	8,0	kV
Body to collector voltage	0	2,5	kV
Cathode current	0,4	0,4	A
Output power, sync	105	105	W
Intermodulation products	≥ −57	≥ −57	dB

**As transposer ( $W_0$  nom 200 W)**

Collector to cathode voltage	12	9	kV
Body to collector voltage	0	3	kV
Cathode current	0,5	0,5	A
Output power, sync	210	210	W
Intermodulation products	≥ −57	≥ −57	dB



## GENERAL NOTES ON POWER SUPPLY DESIGN

	range*	internal resistance	hum
Heater voltage	4,5 to 6,5 V (max 5 A)	The heater current should not exceed a value of 8 A when switching on the supply	Corresponding to non-smoothed three-phase bridge rectifier
Body to collector voltage	0/2,0/2,5/3,0 kV 100 mA continuous 200 mA peak	< 600 $\Omega$	< 0,1%
Collector to cathode voltage**	8,0/8,5/9,5 kV with depressed collector voltage 10,5/11,5 kV without depressed collector voltage	< 600 $\Omega$	< 0,1%
Body to accelerator voltage	Via potentiometer. Total resistance $\approx$ 5 M $\Omega$ and series resistor 10 k $\Omega$ (suitable for 15 kV) between accelerator electrode and tap.		

\* Maximum allowable deviation from nominal or set values:

- a)  $\pm 2\%$  during adjustment, if the published performance is to be attained.
- b)  $\pm 1\%$  fluctuation of the set values during operation to maintain the performance.

\*\* It is recommended that additional taps be made  $\approx$  500 V above and below the indicated values.



## U.H.F. POWER KLYSTRON

For u.h.f. band IV/V sound transmitters and vision transmitters up to 15 kW.  
 Metal-ceramic construction, four external cavities, high-stability dispenser cathode.  
 Suitable for water, vapour, or vapour-condensation cooling.

### QUICK REFERENCE DATA

Frequency range	470 to 860 MHz
Cooling	vapour, vapour condensation, or water

### HEATING; indirect by d.c.

notes: see page B92

Cathode	dispenser type	
Heater voltage	$V_f$	5,5 V *
Heater current	$I_f$	$\approx$ 19 to 26 A note 1
Cold heater resistance	$R_{fo}$	$\approx$ 25 m $\Omega$
Waiting time		note 2
from cold, $V_f = 0$ V	$t_w$	min. 300 s
from black heat, $V_f = 4,5$ V	$t_w$	min. 0 s

### FOCUSING

Focusing coil current	8 to 11 A
Resistance of focusing coils	
cold (20 °C)	7,2 to 9,5 $\Omega$
operating at an ambient temperature of 20 °C	$\leq$ 11 $\Omega$

### BEAM CONTROL

notes 6, 7

The accelerator electrode voltage allows adjustment of the beam current between 0 and 100%.

### GETTER-ION PUMP SUPPLY

Pump voltage, no-load condition	3 to 4 kV
Internal resistance of supply	300 k $\Omega$

\* During operation the heater voltage may not fluctuate more than  $\pm 3\%$ .

MECHANICAL DATA

Dimensions in mm

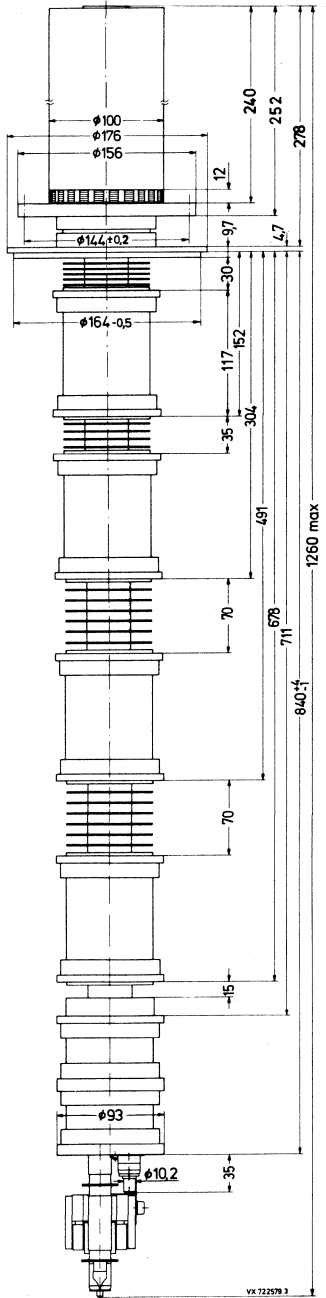

Fig. 1.

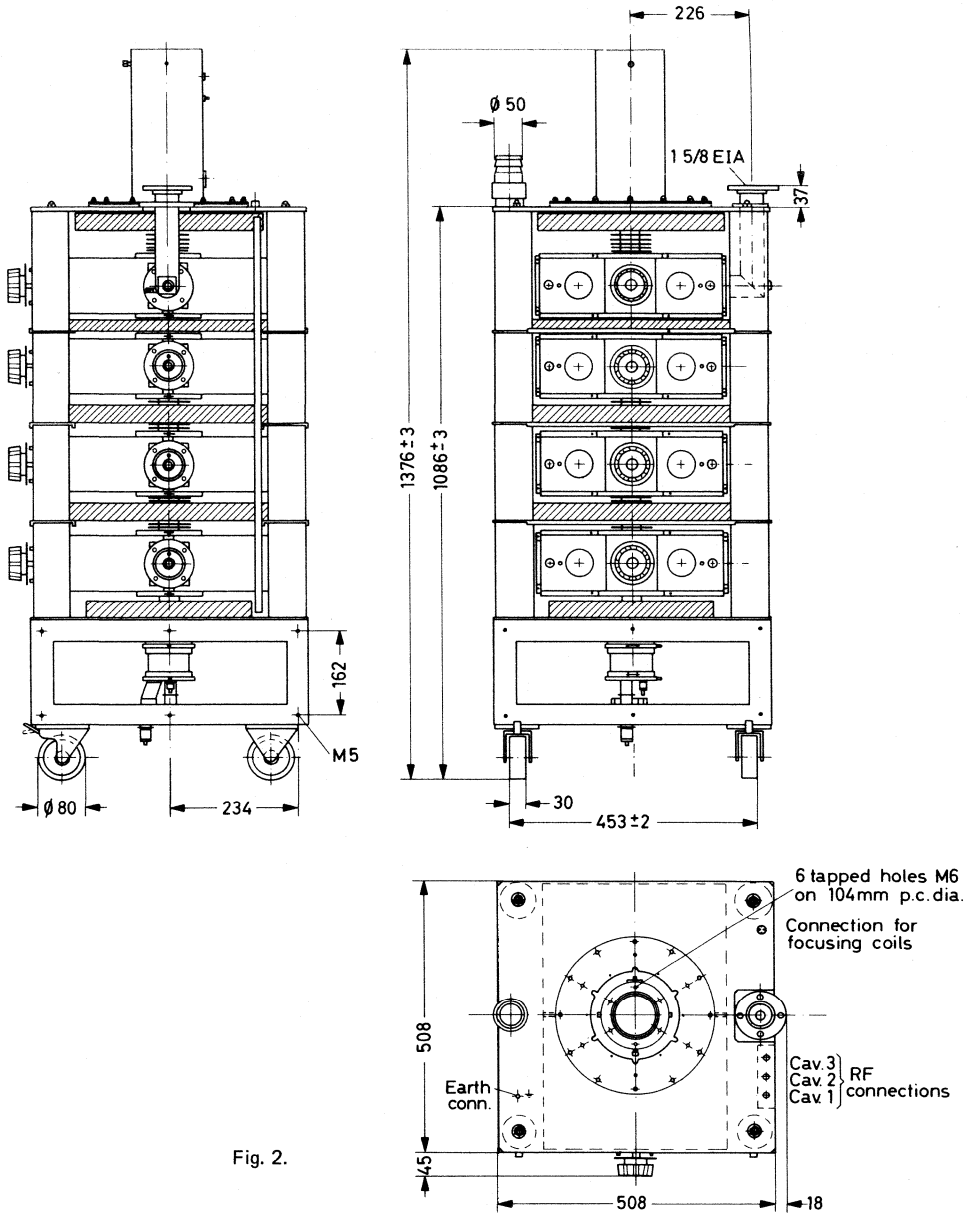

Fig. 2.

VX 722 585. 2

**COOLING**

Cavities 1, 2, 3 and 4, drift tubes 4 and 5 and cathode socket

Cathode socket only, during black heat

Collector

forced air,  $t_i$  max. 50 °C; when using TE1188:  
 $q \approx 1,2 \text{ m}^3/\text{min}$ ,  $p_i = 350 \text{ Pa}$

forced air,  $t_i$  max. 50 °C,  $q \approx 0,15 \text{ m}^3/\text{min}$

vapour with boiler TE1189C, note 4  
 volume of water converted to steam: 27  $\text{cm}^3/\text{min}$   
 per kW collector dissipation resulting in 43  $\ell/\text{min}$   
 steam per kW collector dissipation;

water or vapour condensation (with cooler  
 TE1189A)  $t_o$  max. 90 °C, see graph of Fig. 3.  
 For 10  $\ell/\text{min}$ ,  $p_i = 16 \text{ kPa}$ .

**MASS (net)**

Tube, inclusive cooler or boiler

Cavities

Magnet frame with coils

approx. 25 kg

approx. 45 kg

approx. 220 kg

**MOUNTING**

Mounting position: vertical with collector up

To remove the tube from the magnet frame a total free height of 2,5 m, excluding hoist, is required.

**ACCESSORIES**

Correct operation can be guaranteed only if approved accessories are used.

Collector radiation suppressor	TE1182B	
Spark gap	TE1183	
Set of connectors (heater, cathode, accelerator electrode)	TE1184	
Cavities	4 x TE1185	
	front panel controlled	directly controlled
Inlet coupler and load coupler for cavities 2 and 3	3 x TE1186A	3 x TE1186C
Output coupler 1 $\frac{5}{8}$ inch, 90°-elbow	TE1187A	TE1187B
	—	TE1187C
Magnet frame with coils	TE1188	
Collector jacket for water or vapour condensation cooling	TE1189A	
Boiler for vapour cooling	TE1189C	
Tool set and tube lifting yoke	TE1190	
Temperature sensor	TE1199	
Arc detector (optional)	TE1107	
Isolator (optional)	I 10/IV-N, I 10/V-N or I 10/V-3-N	



**LIMITING VALUES** (Absolute maximum rating system)

Heater voltage	max. 6,5 V
Beam voltage	max. -21 kV
Cold cathode voltage	max. -21 kV
Beam current	max. 3 A
Body current	max. 100 mA
Accelerator electrode current	max. 5 mA note 5
Collector dissipation	max. 42 kW
Load v.s.w.r.	max. 1,5
Temperature of tube envelope	max. 175 °C
Static pressure in the cooling system TE1189A	max. 600 kPa (≈ 6 at)

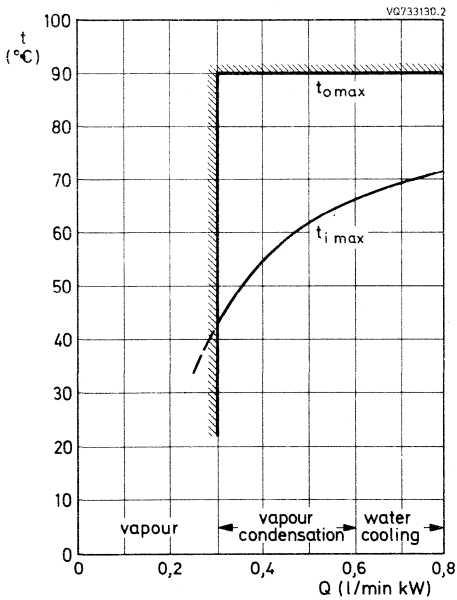

Fig. 3.

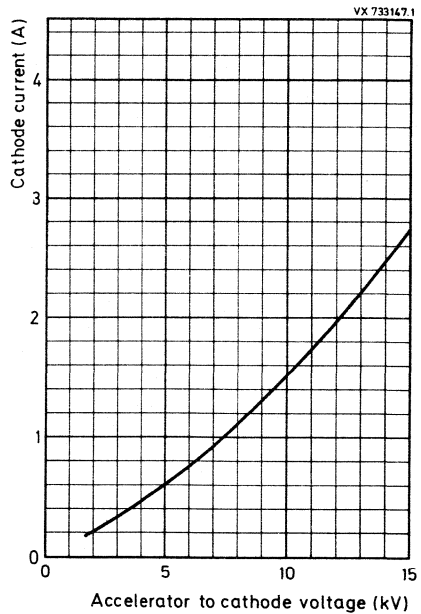

Fig. 4.

**TYPICAL OPERATING CONDITIONS**

**As 10 kW vision transmitter**

	G		I		G		I		G		I		notes
Standard CCIR:													10
Channel	21		45		68								
Output power, peak sync.	11		11		11								kW
Beam voltage	13	13,5	15	15	16	16	16	16	16	16	16	16	kV
Beam current	1,95	2,05	1,55	1,55	1,5	1,5	1,5	1,5	1,5	1,5	1,5	1,5	A 6
Accelerator to cathode voltage	≈ 12	≈ 12,5	≈ 10	≈ 10	≈ 10	≈ 10	≈ 10	≈ 10	≈ 10	≈ 10	≈ 10	≈ 10	kV 7
Body current													
without drive	≈ 10	≈ 10	≈ 7	≈ 7	≈ 7	≈ 7	≈ 7	≈ 7	≈ 7	≈ 7	≈ 7	≈ 7	mA
at black level	≈ 50	≈ 50	≈ 35	≈ 35	≈ 30	≈ 30	≈ 30	≈ 30	≈ 30	≈ 30	≈ 30	≈ 30	mA
Focusing coil current	≈ 10	≈ 10	≈ 9	≈ 9	≈ 9	≈ 9	≈ 9	≈ 9	≈ 9	≈ 9	≈ 9	≈ 9	A
Drive power, peak sync., max.	10	15	6	10	4	8	4	8	4	8	4	8	W 8
Operating efficiency	43	40	47	47	45	45	45	45	45	45	45	45	%
Minimum efficiency	42	40	46	44	44	43	44	43	44	43	44	43	%

**Sound transmitter**

Output power	1,1		2,2		5,5								kW
Beam voltage	13	16	13	16	18,5	18,5	18,5	18,5	18,5	18,5	18,5	18,5	kV
Beam current	0,38	0,3	0,5	0,4	0,8	0,8	0,8	0,8	0,8	0,8	0,8	0,8	A 6
Accelerator to cathode voltage	≈ 3,5	≈ 3,0	≈ 4,5	≈ 3,5	≈ 6,0	≈ 6,0	≈ 6,0	≈ 6,0	≈ 6,0	≈ 6,0	≈ 6,0	≈ 6,0	kV 7
Body current	≈ 15		≈ 15		≈ 15								mA
Focusing coil current	≈ 10		≈ 10		≈ 10								A 9
Drive power, channel 21	4		4		4								W 8
channel 45	2		2		2								W 8
channel 68	1		1		1								W 8
Bandwidth at -1 dB points	≥ 300		≥ 300		≥ 300								kHz
Operating efficiency	22		34		37								%

**TYPICAL OPERATING CONDITIONS** (continued)

**As 15 kW vision transmitter**

	G		I		G		I		notes	
Standard CCIR:										10
Channel	21		45		68					
Output, peak sync.	16,5		16,5		16,5				kW	
Beam voltage	16,5	15,5	17,5	17,5	19	19			kV	
Beam current	2,35	2,6	2,0	2,0	1,95	1,95			A 6	
Accelerator to cathode voltage	≈13,5	≈14,5	≈12	≈12	≈12	≈12			kV 7	
Body current										
without drive	≈10	≈10	≈7	≈7	≈7	≈7			mA	
at black level	≈50	≈70	≈45	≈45	≈40	≈40			mA	
Focusing coil current	≈10	≈10	≈9	≈9	≈9	≈8			A	
Drive power, peak sync. max.	10	15	8	10	6	10			W 8	
Operating efficiency	43	43	47	47	45	45			%	
Minimum efficiency	42	40	46	44	44	43			%	

**Sound transmitter**

Output power	16,5		3,3		kW					
Beam voltage	15,5	19	15,5	19	kV					
Beam current	0,37	0,3	0,63	0,5	A				6	
Accelerator to cathode voltage	≈3,5	≈3,0	≈5,0	≈4,5	kV				7	
Body current	≈15		≈15		mA					
Focusing coil current	≈10		≈10		A				9	
Drive power, channel 21	4		4		W				8	
channel 51	2		2		W				8	
channel 68	1		1		W				8	
Bandwidth at -1 dB points	≥ 300		≥ 300		kHz					
Operating efficiency	29		34		%					



**CAUTION**

To limit X-radiation to officially permissible levels, fit collector radiation suppressor TE1182B and enclose the lower part of the magnet frame TE1188 in 1 mm sheet steel.

Keep away from the tube when it is in operation. R.F. leakage may be sufficient to cause bodily harm, particularly to the eyes. The risk is greater if the tube is functioning incorrectly.

**Notes**

1. When switching on the heater voltage, the heater current must never exceed a peak value of 70 A.
2. In case of a mains failure an interruption up to 30 s can be tolerated without new preheating. After min. 10 minutes of stand-by heating time at 4,5 V (black heat), the beam current may be switched on; the heater voltage must be increased to its nominal value of 5,5 V simultaneously.
3. To ensure that the klystron is always ready for operation, operate the ion getter pump at least every 6 months (preferably every 3 months) during storage. For details see klystron instruction manual.
4. In order to avoid corrosion of the cooling system, coolant water must be pure and deionized (resistivity min. 100 k $\Omega$ .cm).
5. The accelerator electrode voltage must not be positive with respect to the body (ground).
6. For cathode current (tolerance  $\pm 5\%$ ) versus accelerator-to-cathode voltage, see Fig. 4.
7. Connect the accelerator electrode to its supply (power supply or voltage divider) via a 10 k $\Omega$  resistor. A voltage divider for adjusting the cathode current should be dimensioned on the basis of an accelerator electrode current of max. 1,5 mA.
8. The drive power is defined as the power delivered to a matched load.
9. Value is not critical. It may be set in accordance with the vision klystron focusing coil current. Operation of one vision and one sound klystron focusing unit in series is permissible.
10. Standard CCIR-G: klystron tuned to frequency response according to the specification CCIR-G. Standard CCIR-I: klystron tuned to frequency response according to the following diagram:

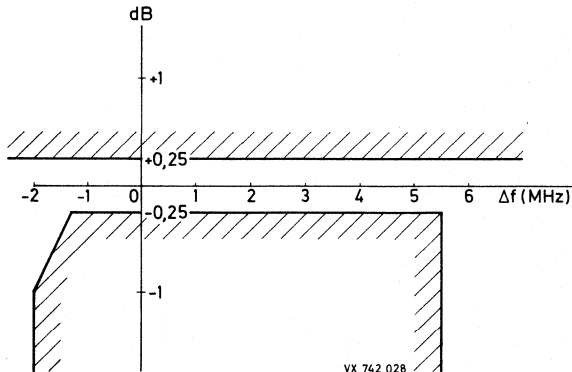

# DEVELOPMENT SAMPLE DATA

This information is derived from development samples made available for evaluation. It does not necessarily imply that the device will go into regular production.

YK1223

## U.H.F. POWER KLYSTRON

For u.h.f. band IV/V sound transmitters and vision transmitters of 10 and 15 kW.

Metal-ceramic construction, four external cavities, electromagnetic focusing and a high-stability dispenser-type cathode.

Suitable for water, vapour, or vapour-condensation cooling.

Comprising a non-intercepting annular beam control electrode for low-voltage beam modulation.

### QUICK REFERENCE DATA

Frequency range	470 to 860 MHz
Cooling	vapour, vapour condensation, or water

### HEATING; indirect by d.c.

notes: see page 8

Cathode	dispenser type
Heater voltage	$V_f$ 5,5 V*
Heater current	$I_f \approx$ 19 to 26 A note 1
Cold heater resistance	$R_{fo} \approx$ 25 m $\Omega$
Waiting time	note 2
from cold, $V_f = 0$ V	$t_w$ min. 300 s
from black heat, $V_f = 4,5$ V	$t_w$ min. 0 s

### FOCUSING

Focusing coil current	8 to 11 A
Resistance of focusing coils	
cold (20 °C)	7,2 to 9,5 $\Omega$
operating at an ambient temperature of 20 °C	$\leq$ 11 $\Omega$

### BEAM CONTROL

notes 6,7

The accelerator electrode voltage allows adjustment of the beam current between 0 and 100%.

### GETTER-ION PUMP SUPPLY

Pump voltage, no-load condition	3 to 4 kV
Internal resistance of supply	300 k $\Omega$

\* During operation the heater voltage may not fluctuate more than  $\pm 3\%$ .

MECHANICAL DATA

Dimensions in mm

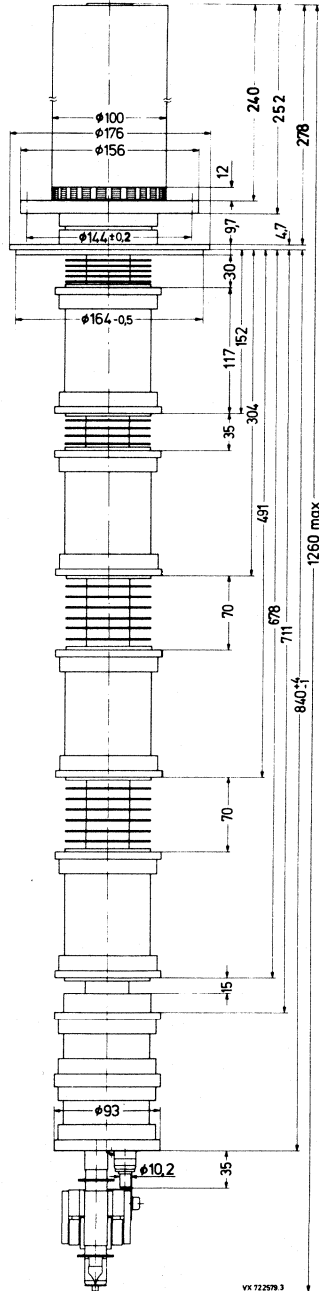

Fig. 1.

DEVELOPMENT SAMPLE DATA

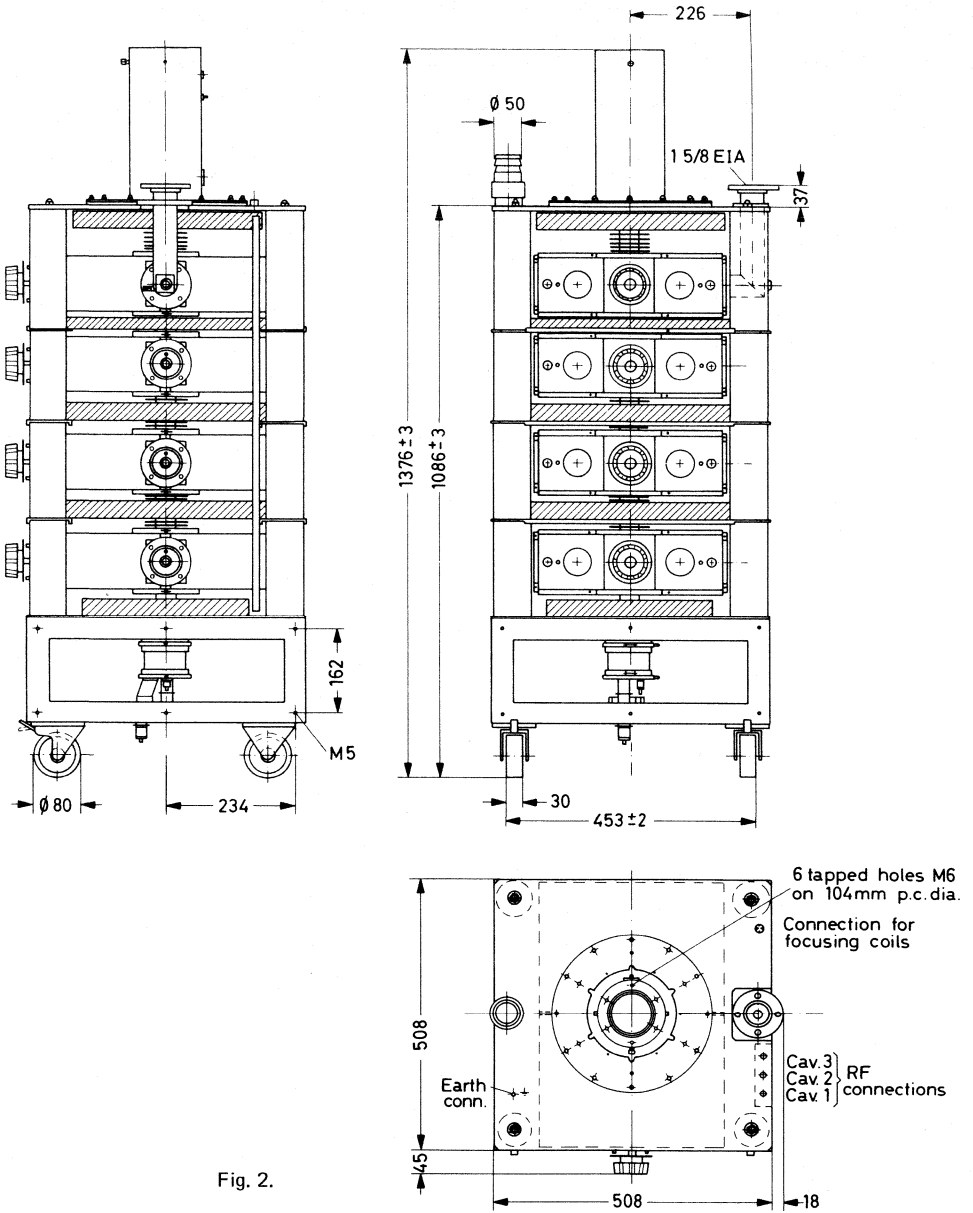

Fig. 2.

VX 722 585. 2

**COOLING**

Cavities 1, 2, 3 and 4, drift tubes 4 and 5 and cathode socket

Cathode socket only, during black heat  
Collector

forced air,  $t_i$  max. 50 °C; when using TE1188:  
 $q \approx 1,2 \text{ m}^3/\text{min}$ ,  $p_i = 350 \text{ Pa}$

forced air,  $t_i$  max. 50 °C,  $q \approx 0,15 \text{ m}^3/\text{min}$   
vapour with boiler TE1189C, note 4  
volume of water converted to steam: 27  $\text{cm}^3/\text{min}$   
per kW collector dissipation resulting in 43  $\ell/\text{min}$   
steam per kW collector dissipation;  
water or vapour condensation (with cooler  
TE1189A)  $t_o$  max. 90 °C, see graph of Fig. 3.  
For 10  $\ell/\text{min}$ ,  $p_i = 16 \text{ kPa}$ .

**MASS (net)**

Tube, inclusive cooler or boiler  
Cavities  
Magnet frame with coils

approx. 25 kg  
approx. 45 kg  
approx. 220 kg

**MOUNTING**

Mounting position: vertical with collector up

To remove the tube from the magnet frame a total free height of 2,5 m, excluding hoist, is required.

**ACCESSORIES**

Correct operation can be guaranteed only if approved accessories are used.

Collector radiation suppressor	TE1182B	
Spark gap	TE1183	
Set of connectors (heater, cathode, accelerator electrode)	TE1184	
Cavities	4 x TE1185	
	front panel controlled	directly controlled
Inlet coupler and load coupler for cavities 2 and 3	3 x TE1186A	3 x TE1186C
Output coupler		
$1\frac{5}{8}$ inch, 90°-elbow	TE1187A	TE1187B
$3\frac{1}{8}$ inch, 90°-elbow	—	TE1187C
Magnet frame with coils	TE1188	
Collector jacket for water or vapour condensation cooling	TE1189A	
Boiler for vapour cooling	TE1189C	
Tool set and tube lifting yoke	TE1190	
Temperature sensor	TE1199	
Arc detector (optional)	TE1107	
Isolator (optional)	I 10/IV-N, I 10/V-N or I 10/V-3-N	



**LIMITING VALUES** (Absolute maximum rating system)

Heater voltage	max.	6,5 V	
Beam voltage	max.	-21 kV	
Cold cathode voltage	max.	-21 kV	
Beam current	max.	3 A	
Body current	max.	100 mA	
Accelerator electrode current	max.	5 mA	note 5
Collector dissipation	max.	42 kW	
Load v.s.w.r.	max.	1,5	
Temperature of tube envelope	max.	175 °C	
Static pressure in the cooling system TE1189A	max.	600 kPa	(≈ 6 at)

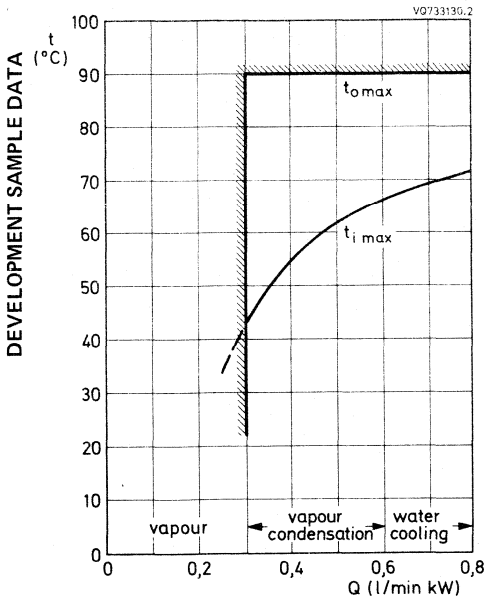

Fig. 3.

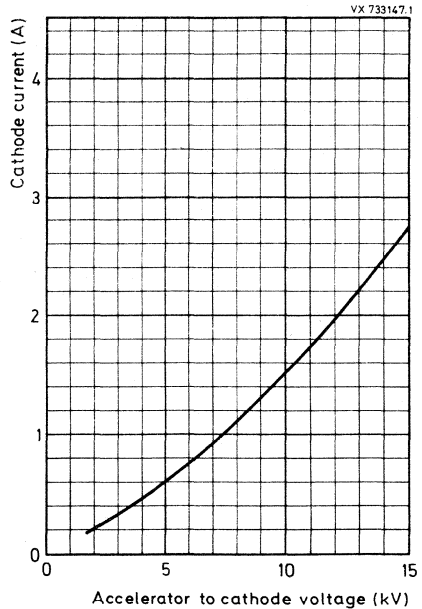

Fig. 4.

## TYPICAL OPERATING CONDITIONS

## As 10 kW vision transmitter

	G		I		G		I		G		I		notes
Standard CCIR:	21		45		68								10
Channel	11		11		11								
Output power, peak sync.	13		13,5		15		15		16		16		kW
Beam voltage	1,95	2,05	1,55	1,55	1,5	1,5	A	6					
Beam current	≈ 12	≈ 12,5	≈ 10	≈ 10	≈ 10	≈ 10	kV	7					
Accelerator to cathode voltage	≈ 10		≈ 10		≈ 7		≈ 7		≈ 7		≈ 7		mA
Body current without drive	≈ 50	≈ 50	≈ 35	≈ 35	≈ 30	≈ 30	mA						
at black level	≈ 10	≈ 10	≈ 9	≈ 9	≈ 9	≈ 9	A						
Focusing coil current	10	10	6	10	4	8	W	8					
Drive power, peak sync., max.	43	40	47	47	45	45	%						
Operating efficiency	42	40	46	44	44	43	%						
Minimum efficiency													

## Sound transmitter

	1,1		2,2		5,5		
Output power	13	16	13	16	18,5		kV
Beam voltage	0,38	0,3	0,5	0,4	0,8	A	6
Beam current	≈ 3,5	≈ 3,0	≈ 4,5	≈ 3,5	≈ 6,0	kV	7
Accelerator to cathode voltage	≈ 15		≈ 15		≈ 15	mA	
Body current	≈ 10		≈ 10		≈ 10	A	9
Focusing coil current	4		4		4	W	8
Drive power, channel 21	2		2		2	W	8
channel 45	1		1		1	W	8
channel 68	≥ 300		≥ 300		≥ 300	kHz	
Bandwidth at -1 dB points	22		34		37	%	
Operating efficiency							

## TYPICAL OPERATING CONDITIONS (continued)

## As 15 kW vision transmitter

	G		I		G		I		G		I		notes
Standard CCIR:	21		45		68								10
Channel	16,5		16,5		16,5								
Output, peak sync.	16,5		15,5		17,5		17,5		19		19 kV		
Beam voltage	2,35		2,6		2,0		2,0		1,95		1,95 A		6
Beam current	≈ 13,5		≈ 14,5		≈ 12		≈ 12		≈ 12		≈ 12 kV		7
Accelerator to cathode voltage													
Body current													
without drive	≈ 10		≈ 10		≈ 7		≈ 7		≈ 7		≈ 7 mA		
at black level	≈ 50		≈ 70		≈ 45		≈ 45		≈ 40		≈ 40 mA		
Focusing coil current	≈ 10		≈ 10		≈ 9		≈ 9		≈ 9		≈ 8 A		
Drive power, peak sync. max.	10		15		8		10		6		10 W		8
Operating efficiency	43		43		47		47		45		45 %		
Minimum efficiency	42		40		46		44		44		43 %		

## Sound transmitter

	16,5		3,3		kW				
Output power	16,5		3,3		kW				
Beam voltage	15,5		19		15,5		19 kV		
Beam current	0,37		0,3		0,63		0,5 A		6
Accelerator to cathode voltage	≈ 3,5		≈ 3,0		≈ 5,0		≈ 4,5 kV		7
Body current	≈ 15		≈ 15		≈ 15		mA		
Focusing coil current	≈ 10		≈ 10		≈ 10		A		9
Drive power,									
channel 21	4		4		4		W		8
channel 51	2		2		2		W		8
channel 68	1		1		1		W		8
Bandwidth at -1 dB points	≥ 300		≥ 300		≥ 300		kHz		
Operating efficiency	29		34		34		%		



**CAUTION**

To limit X-radiation to officially permissible levels, fit collector radiation suppressor TE1182B and enclose the lower part of the magnet frame TE1188 in 1 mm sheet steel.

Keep away from the tube when it is in operation. R.F. leakage may be sufficient to cause bodily harm, particularly to the eyes. The risk is greater if the tube is functioning incorrectly.

**Notes**

1. When switching on the heater voltage, the heater current must never exceed a peak value of 70 A.
2. In case of a mains failure an interruption up to 30 s can be tolerated without new preheating. After min. 10 minutes of stand-by heating time at 4,5 V (black heat), the beam current may be switched-on; the heater voltage must be increased to its nominal value of 5,5 V simultaneously.
3. To ensure that the klystron is always ready for operation, operate the ion getter pump at least every 6 months (preferably every 3 months) during storage. For details see klystron instruction manual.
4. In order to avoid corrosion of the cooling system, coolant water must be pure and deionized (resistivity min. 100 k $\Omega$ .cm).
5. The accelerator electrode voltage must not be positive with respect to the body (ground).
6. For cathode current (tolerance  $\pm$  5%) versus accelerator-to-cathode voltage, see Fig. 4.
7. Connect the accelerator electrode to its supply (power supply or voltage divider) via a 10 k $\Omega$  resistor. A voltage divider for adjusting the cathode current should be dimensioned on the basis of an accelerator electrode current of max. 1,5 mA.
8. The drive power is defined as the power delivered to a matched load.
9. Value is not critical. It may be set in accordance with the vision klystron focusing coil current. Operation of one vision and one sound klystron focusing unit in series is permissible.
10. Standard CCIR-G: klystron tuned to frequency response according to the specification CCIR-G  
Standard CCIR-I: klystron tuned to frequency response according to the following diagram:

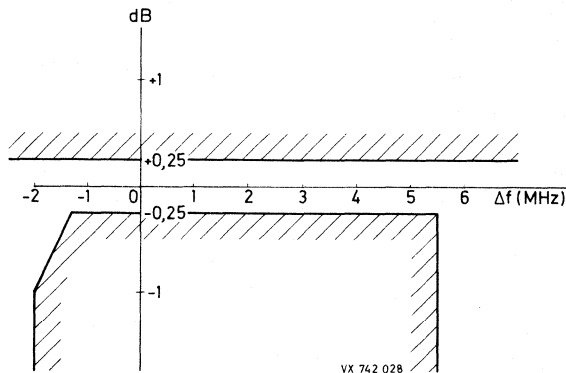

11. For sound operation cavity 3 needs no loading. Instead of load coupler TE1186 A/C use the blanking plate supplied with magnet frame TE1188.

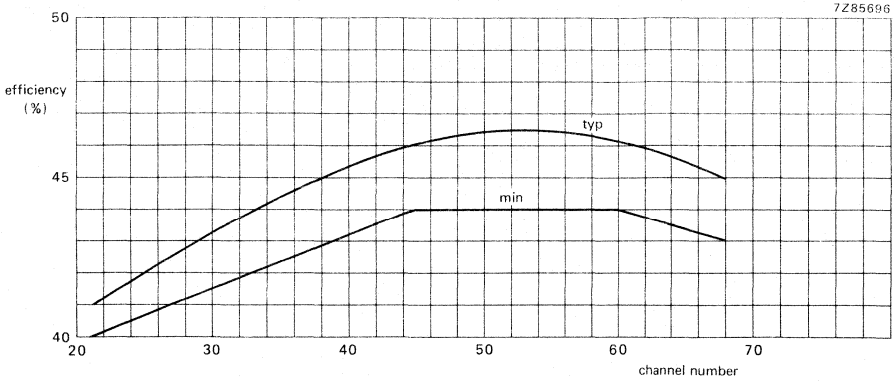

Fig. 5.

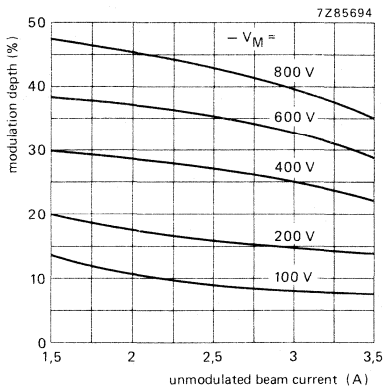

Fig. 6.

DEVELOPMENT SAMPLE DATA





## U.H.F. POWER KLYSTRON

For u.h.f. band IV/V sound transmitters and vision transmitters up to 25 kW.  
Metal-ceramic construction, four external cavities, high-stability dispenser cathode.  
Suitable for water, vapour, or vapour-condensation cooling.

### QUICK REFERENCE DATA

Frequency range	470 to 860 MHz
Cooling	vapour, vapour condensation, or water

**HEATING;** indirect by d.c.

notes: see page B110

Cathode	dispenser type		
Heater voltage	$V_f$		5,5 V *
Heater current	$I_f$	≈	19 to 26 A note 1
Cold heater resistance	$R_{fo}$	≈	25 mΩ
Waiting time			note 2
from cold, $V_f = 0$ V	$t_w$	min.	300 s
from black heat, $V_f = 4,5$ V	$t_w$	min.	0 s

### FOCUSING

Focusing coil current		8 to 11 A
Resistance of focusing coils		
cold (20 °C)		7,2 to 9,5 Ω
operating at an ambient temperature of 20 °C	≤	11 Ω

### BEAM CONTROL

notes 6, 7

The accelerator electrode voltage allows adjustment of the beam current between 0 and 100%.

### GETTER-ION PUMP SUPPLY

note 3

Pump voltage, no-load condition	3 to 4 kV
Internal resistance of supply	300 kΩ

\* During operation the heater voltage may not fluctuate more than ± 3%.

MECHANICAL DATA

Dimensions in mm

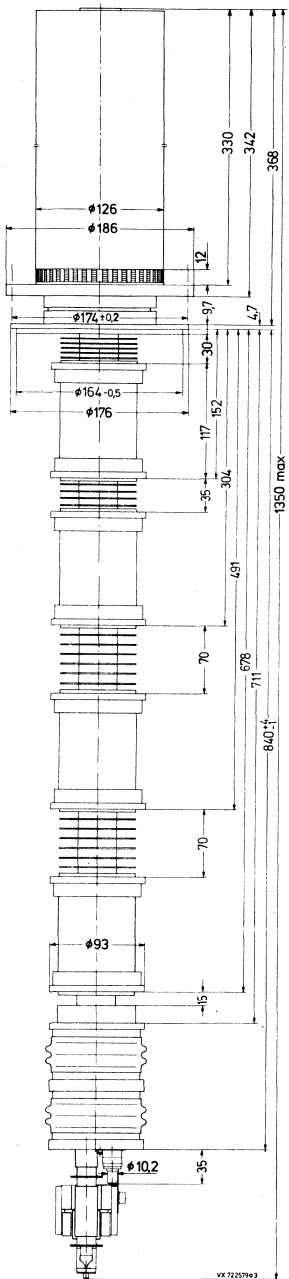

Fig. 1.



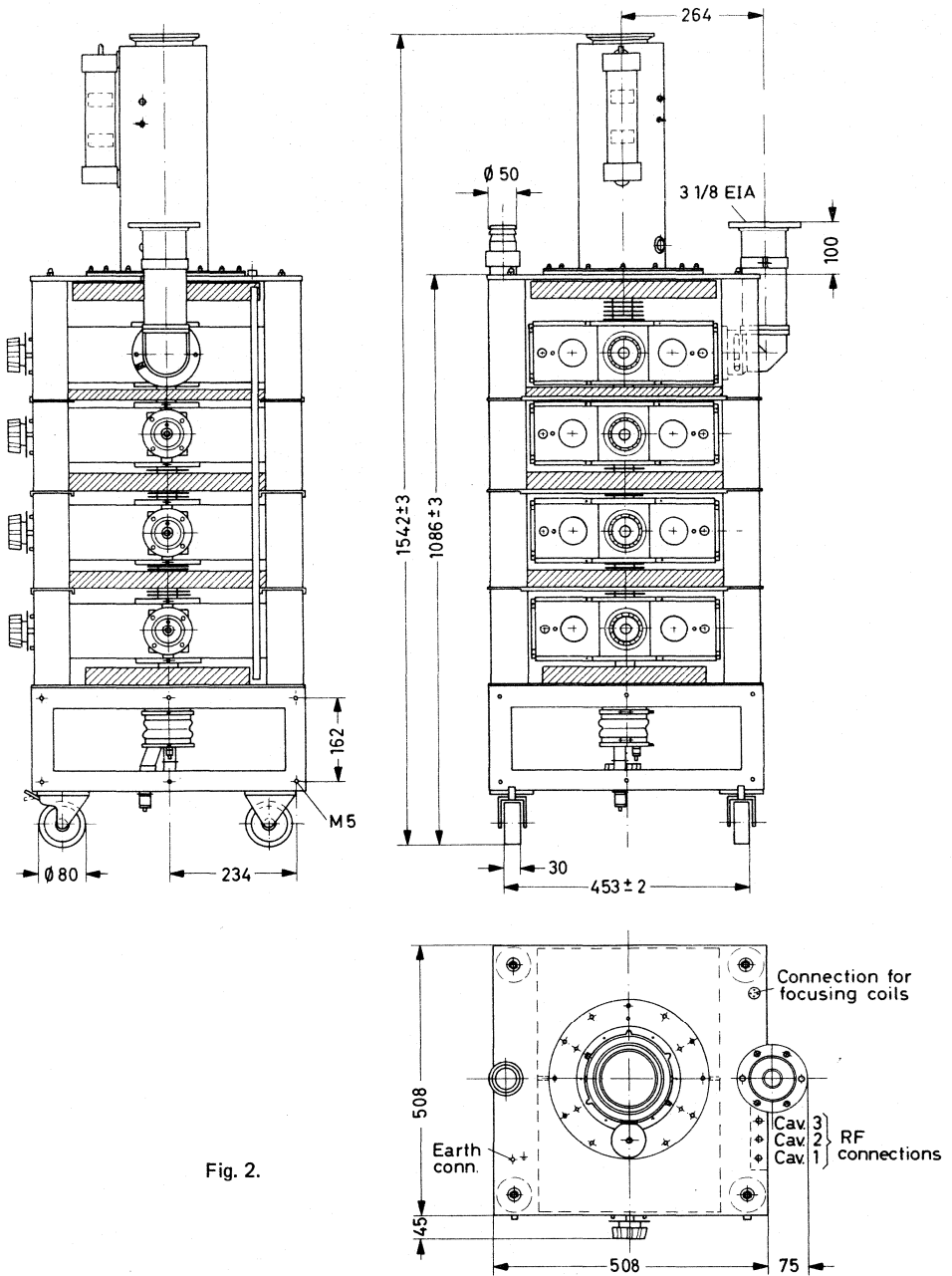

Fig. 2.

VX 722 585a2

**COOLING**

Cavities 1,2,3 and 4, drift tubes 4 and 5 and cathode socket

forced air,  $t_i$  max. 50 °C; when using TE1188:  
 $q \approx 1,2 \text{ m}^3/\text{min}$ ,  $p_i = 350 \text{ Pa}$

Cathode socket only, during black heat

forced air,  $t_i$  max. 50 °C,  $q \approx 0,15 \text{ m}^3/\text{min}$

Collector

vapour with boiler TE1189D, note 4  
 volume of water converted to steam:  $27 \text{ cm}^3/\text{min}$   
 per kW collector dissipation resulting in  $43 \text{ l}/\text{min}$   
 steam per kW collector dissipation;

water or vapour condensation (with cooler TE1189B)  $q = 16 \text{ to } 36 \text{ l}/\text{min}$ ,  $t_o$  max 90 °C,  
 see graph of Fig. 3. For  $10 \text{ l}/\text{min}$ ,  $p_i = 16 \text{ kPa}$ .

**MASS (net)**

Tube incl. cooler or boiler

approx. 30 kg

Cavities

approx. 45 kg

Magnet frame with coils

approx. 220 kg

**MOUNTING**

Mounting position: vertical with collector up

To remove the tube from the magnet frame a total free height of 2,5 m, excluding hoist, is required.

**ACCESSORIES**

Correct operation can be guaranteed only if approved accessories are used.

Collector radiation suppressor

TE1182B

Spark gap

TE1183

Set of connectors

(heater, cathode, accelerator electrode)

TE1184

Cavities

3 x TE1185A

1 x TE1185B

Inlet coupler and load coupler for cavities 2 and 3

	front panel controlled	directly controlled
	3 x TE1186A	3 x TE1186C

Output coupler

$3\frac{1}{8}$  inch, 90°-elbow

—

TE1187C

$3\frac{1}{8}$  inch, straight

—

TE1187D

Magnet frame with coils

TE1188

Collector jacket for water or vapour  
 condensation cooling

TE1189F

Boiler for vapour cooling

TE1189D

Tool set and tube lifting yoke

TE1190

Temperature sensor

TE1199

Arc detector

TE1107

Isolator (optional)

T100/IV-N,T100/V-N or  
 T100/V-3-N

**LIMITING VALUES** (Absolute maximum rating system)

Heater voltage	max. 6,5 V
Beam voltage	max. 26 kV
Cold cathode voltage	max. -26 kV
Beam current	max. 3,8 A
Body current	max. 120 mA
Accelerator electrode current	max. 5 mA note 5
Collector dissipation	max. 70 kW
Load v.s.w.r.	max. 1,5
Temperature of tube envelope	max. 175 °C
Static pressure in the cooling system TE1189B	max. 600 kPa (≈ 6 at)

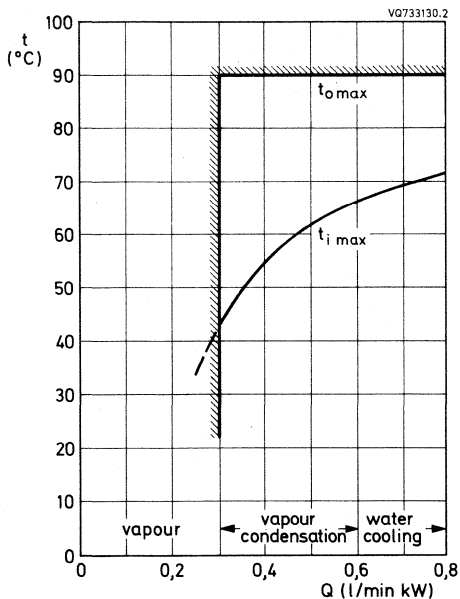

Fig. 3.

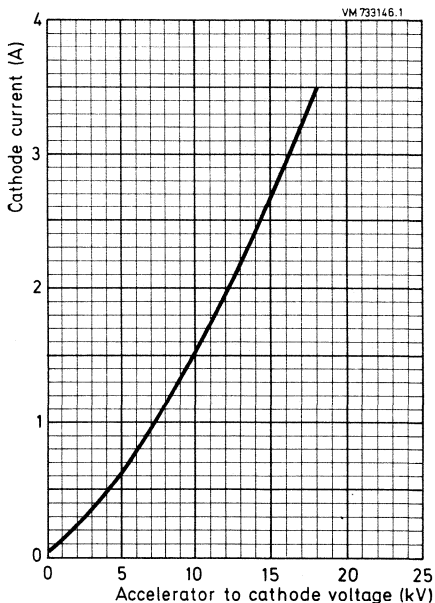

Fig. 4.

**TYPICAL OPERATING CONDITIONS**

**As 20 kW vision transmitter**

				notes
Standard CCIR:	G	G	G	9
Channel	21	45	68	
Output power, peak sync.	22	22	22 kW	
Beam voltage	19,5	20	22 kV	
Beam current	2,7	2,45	2,2 A	6
Accelerator to cathode voltage	≈ 15	≈ 14	≈ 13 kV	7
Body current				
without drive	≈ 10	≈ 7	≈ 7 mA	
at black level	≈ 50	≈ 45	≈ 40 mA	
Focusing coil current	≈ 10	≈ 9	≈ 9 A	
Drive power, peak sync.	15	10	10 W	8
Operating efficiency	42	45	45 %	
Minimum efficiency	41	44	44 %	

**Sound transmitter**

	2,2		4,4		kW
Output power					
Beam voltage	19,5	22	19,5	22	kV
Beam current	0,4	0,35	0,6	0,55	A
Accelerator to cathode voltage	≈ 3,5	≈ 3,0	≈ 5,0	≈ 4,5	kV
Body current	≈ 15		≈ 15		mA
Focusing coil current	≈ 10		≈ 10		A
Drive power,					
channel 21	4		4		W
channel 45	2		2		W
channel 68	1		1		W
Bandwidth at -1 dB points	≥ 300		≥ 300		kHz
Operating efficiency	28		37		%

## TYPICAL OPERATING CONDITIONS (continued)

## As 25 kW vision transmitter

	G		I		G		I		G		I		notes
Standard CCIR:													10
Channel	21		19		45		21,5		23,5		68		
Output power, peak sync.	27		27		27		27		27		kW		
Beam voltage	21	19	21,5	19	21,5	21,5	23,5	21,5	23,5	23,5	kV		
Beam current	3	3,45	2,8	2,8	2,8	2,8	2,5	2,55	2,5	2,55	A		6
Accelerator to cathode voltage	≈ 16	≈ 17,5	≈ 15	≈ 15	≈ 15	≈ 15	≈ 14	≈ 14	≈ 14	≈ 14	kV		7
Body current													
without drive	≈ 10	≈ 10	≈ 7	≈ 7	≈ 7	≈ 7	≈ 7	≈ 7	≈ 7	≈ 7	mA		
at black level	≈ 60	≈ 80	≈ 50	≈ 50	≈ 50	≈ 50	≈ 45	≈ 50	≈ 45	≈ 50	mA		
Focusing coil current	≈ 10	≈ 10	≈ 9	≈ 9	≈ 9	≈ 9	≈ 9	≈ 9	≈ 9	≈ 9	A		
Drive power, peak sync., max.	15	25	10	20	10	20	10	20	10	20	W		8
Operating efficiency	42	41	45	45	45	45	46	45	46	45	%		
Minimum efficiency	41	40	44	44	44	44	44	43	44	43	%		

## Sound transmitter

Output power	5,5				kW		
Beam voltage	19	23,5			kV		
Beam current	0,7	0,55			A		6
Accelerator to cathode voltage	≈ 5,5	≈ 4,5			kV		7
Body current	≈ 15				mA		
Focusing coil current	≈ 10				A		9
Drive power,							
channel 21	4				W		8
channel 45	2				W		8
channel 68	1				W		8
Bandwidth at -1 dB points	≥ 300				kHz		
Operating efficiency	41				%		

Notes see next page.

**CAUTION**

To limit X-radiation to officially permissible levels, fit collector radiation suppressor TE1182B and enclose the lower part of the magnet frame TE1188 in 1 mm sheet steel.

Keep away from the tube when it is in operation. R.F. leakage may be sufficient to cause bodily harm, particularly to the eyes. The risk is greater if the tube is functioning incorrectly.

**Notes**

1. When switching on the heater voltage, the heater current must never exceed a peak value of 70 A.
2. In case of a mains failure an interruption up to 30 s can be tolerated without new preheating. After min. 10 minutes of stand-by heating time at 4,5 V (black heat), the beam current may be switched on; the heater voltage must be increased to its nominal value of 5,5 V simultaneously.
3. To ensure that the klystron is always ready for operation, operate the ion getter pump at least every 6 months (preferably every 3 months) during storage. For details see klystron instruction manual.
4. In order to avoid corrosion of the cooling system, coolant water must be pure and deionized (resistivity min. 100 kΩ.cm).
5. The accelerator electrode voltage must not be positive with respect to the body (ground).
6. For cathode current (tolerance  $\pm 5\%$ ) versus accelerator-to-cathode voltage, see Fig. 4.
7. Connect the accelerator electrode to its supply (power supply or voltage divider) via a 10 kΩ resistor. A voltage divider for adjusting the cathode current should be dimensioned on the basis of an accelerator electrode current of max. 1,5 mA.
8. The drive power is defined as the power delivered to a matched load.
9. Value is not critical. It may be set in accordance with the vision klystron focusing coil current. Operation of one vision and one sound klystron focusing unit in series is permissible.
10. Standard CCIR-G: klystron tuned to frequency response according to the specification CCIR-G  
Standard CCIR-I: klystron tuned to frequency response according to the following diagram:

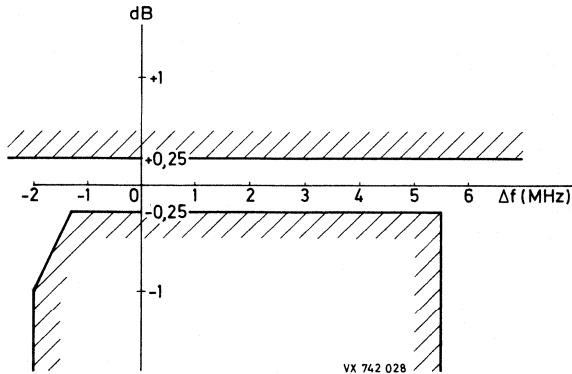

## DEVELOPMENT SAMPLE DATA

This information is derived from development samples made available for evaluation. It does not necessarily imply that the device will go into regular production.

YK1233

## U.H.F. POWER KLYSTRON

For u.h.f. band IV/V sound transmitters and vision transmitters of 20 and 25 kW.

Metal-ceramic construction, four external cavities, electromagnetic focusing and a high-stability dispenser-type cathode.

Suitable for water, vapour, or vapour-condensation cooling.

Comprising a non-intercepting annular beam control electrode for low-voltage beam modulation.

### QUICK REFERENCE DATA

Frequency range	470 to 860 MHz
Cooling	vapour, vapour condensation, or water

### HEATING; indirect by d.c.

notes: see page B118

Cathode	dispenser type		
Heater voltage	$V_f$	5,5 V*	
Heater current	$I_f \approx$	19 to 26 A	note 1
Cold heater resistance	$R_{fo} \approx$	25 m $\Omega$	
Waiting time			note 2
from cold, $V_f = 0$ V	$t_w$ min.	300 s	
from black heat, $V_f = 4,5$ V	$t_w$ min.	0 s	

### FOCUSING

Focusing coil current	8 to 11 A
Resistance of focusing coils	
cold (20 °C)	7,2 to 9,5 $\Omega$
operating at an ambient temperature of 20 °C	$\leq$ 11 $\Omega$

### BEAM CONTROL

notes 6, 7

The klystron comprises a non-intercepting annular beam control electrode for low-voltage beam modulation. See Fig. 6.

The accelerator electrode voltage allows adjustment of the beam current between 0 and 100%.

### GETTER-ION PUMP SUPPLY

note 3

Pump voltage, no-load condition	3 to 4 kV
Internal resistance of supply	300 k $\Omega$

\* During operation the heater voltage may not fluctuate more than  $\pm 3\%$ .

MECHANICAL DATA

Dimensions in mm

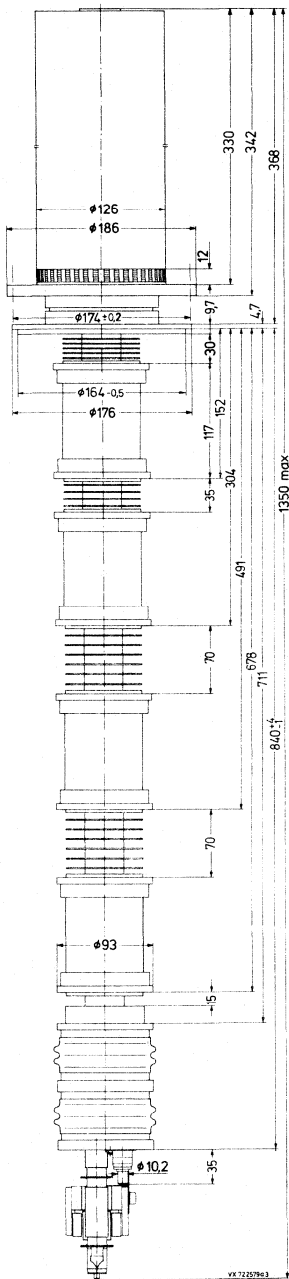

Fig. 1.



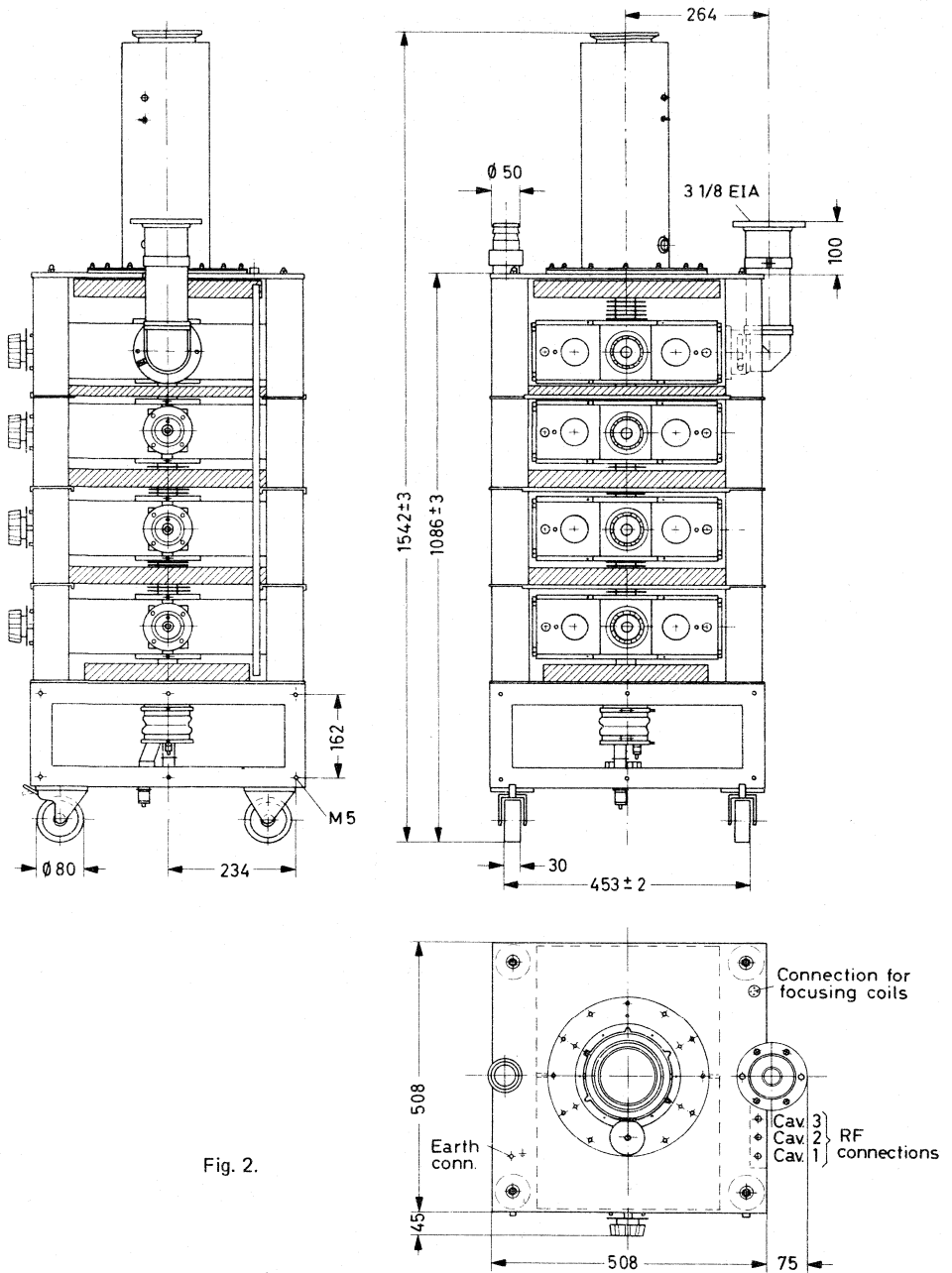

Fig. 2.

VX 722 585a3

**COOLING**

Cavities 1,2,3 and 4, drift tubes 4 and 5 and cathode socket

forced air,  $t_i$  max. 50 °C;  
 $q \approx 1,2 \text{ m}^3/\text{min}$ ,  $p_i = 350 \text{ Pa}$

Cathode socket only, during black heat  
 Collector

forced air,  $t_i$  max. 50 °C,  $q \approx 0,15 \text{ m}^3/\text{min}$   
 vapour with boiler TE1189D, note 4  
 volume of water converted to steam:  $27 \text{ cm}^3/\text{min}$   
 per kW collector dissipation resulting in  $43 \text{ l}/\text{min}$   
 steam per kW collector dissipation;  
 water or vapour condensation (with cooler  
 TE1189F)  $q = 16 \text{ to } 36 \text{ l}/\text{min}$ ,  $t_o$  max 90 °C,  
 see graph of Fig. 3. For  $10 \text{ l}/\text{min}$ ,  $p_i = 16 \text{ kPa}$ .

**MASS (net)**

Tube incl. cooler or boiler  
 Cavities  
 Magnet frame with coils

approx. 40 kg  
 approx. 45 kg  
 approx. 220 kg

**MOUNTING**

Mounting position: vertical with collector up

To remove the tube from the magnet frame a total free height of 2,5 m, excluding hoist, is required.

**ACCESSORIES**

Correct operation can be guaranteed only if approved accessories are used.

Collector radiation suppressor

TE1182B

Spark gap

TE1183

Set of connectors

(heater, cathode, accelerator electrode, getter-ion pump)

TE1184

Cavities

3 x TE1185A  
 1 x TE1185B

Inlet coupler and load coupler for cavities 2 and 3

	front panel controlled	directly controlled
	3 x TE1186A	3 x TE1186C note 11

Output coupler

$3\frac{1}{8}$  inch, 90°-elbow

—

TE1187C

$3\frac{1}{8}$  inch, straight

—

TE1187D

Magnet frame with coils

TE1188

Collector jacket for water or vapour  
 condensation cooling

TE1189F

Boiler for vapour cooling

TE1189D

Tool set and tube lifting yoke

TE1190

Temperature sensor

TE1199

Arc detector

TE1107

Recommended circulators (optional)

470 to 600 MHz

2722 162 01551 (T100/IV-N)

600 to 800 MHz

2722 162 01561 (T100/V-N)

790 to 1000 MHz

2722 162 03261 (T100/V-3-N)

**LIMITING VALUES** (Absolute maximum rating system)

Heater voltage	max. 6,5 V
Beam voltage	max. 26 kV
Cold cathode voltage	max. -26 kV
Beam current	max. 3,8 A
Body current	max. 120 mA
Accelerator electrode current	max. 5 mA note 5
Collector dissipation	max. 70 kW
Load v.s.w.r.	max. 1,5
Temperature of tube envelope	max. 175 °C
Static pressure in the cooling system TE1189F	max. 600 kPa (≈ 6 at)
Focusing coil current	max. 11,5 A
Modulation electrode voltage	max. 1000 V

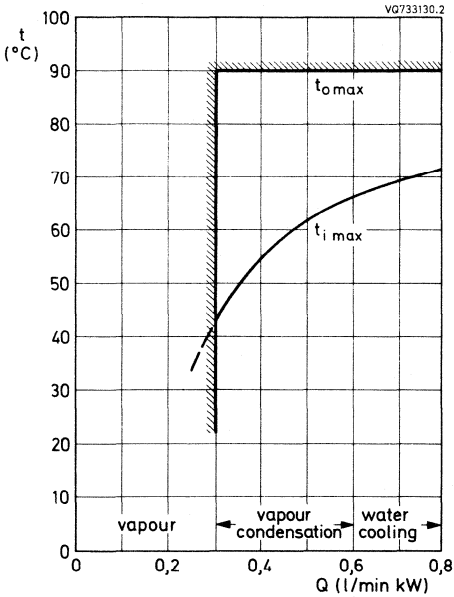

Fig. 3.

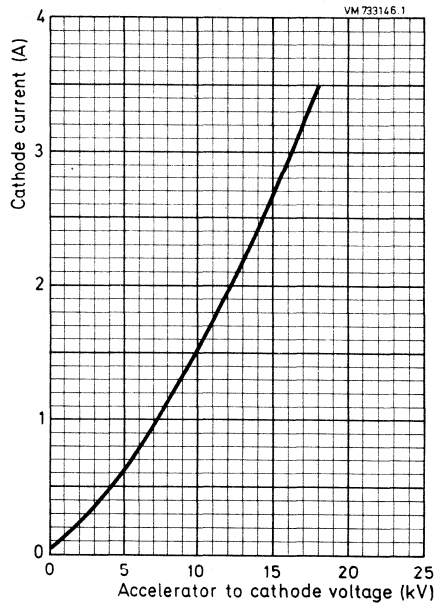

Fig. 4.

**TYPICAL OPERATING CONDITIONS, (modulation electrode at cathode potential)**

**As 20 kW vision transmitter**

	G	G	G	notes
Standard CCIR:				9
Channel	21	45	68	
Output power, peak sync.	22	22	22 kW	
Beam voltage	19,5	20	22 kV	
Beam current	2,7	2,45	2,2 A	6
Accelerator to cathode voltage	≈ 15	≈ 14	≈ 13 kV	7
Body current				
without drive	≈ 10	≈ 7	≈ 7 mA	
at black level	≈ 50	≈ 45	≈ 40 mA	
Focusing coil current	≈ 10	≈ 9	≈ 9 A	
Drive power, peak sync.	15	10	10 W	8
Operating efficiency	42	45	45 %	
Minimum efficiency	41	44	44 %	

**Sound transmitter**

	2,2		4,4		kW
Output power					
Beam voltage	19,5	22	19,5	22	kV
Beam current	0,4	0,35	0,6	0,55	A
Accelerator to cathode voltage	≈ 3,5	≈ 3,0	≈ 5,0	≈ 4,5	kV
Body current	≈ 15		≈ 15		mA
Focusing coil current	≈ 10		≈ 10		A
Drive power,					
channel 21	4		4		W
channel 45	2		2		W
channel 68	1		1		W
Bandwidth at -1 dB points	≥ 300		≥ 300		kHz
Operating efficiency	28		37		%



## TYPICAL OPERATING CONDITIONS (continued)

## As 25 kW vision transmitter

Standard CCIR:	G		I		G		I		G		I		notes
	21	27	19	27	45	27	21,5	21,5	68	27	23,5	23,5	
Channel	21		19		45		21,5	21,5	68		23,5	23,5	10
Output power, peak sync.		27		27		27		27		27		27	kW
Beam voltage	21		19		21,5	21,5	21,5	21,5	23,5	23,5	23,5	23,5	kV
Beam current	3	3,45			2,8	2,8	2,8	2,8	2,5	2,55	2,55	2,55	A
Accelerator to cathode voltage	≈ 16	≈ 17,5			≈ 15	≈ 15	≈ 15	≈ 15	≈ 14	≈ 14	≈ 14	≈ 14	kV
Body current													
without drive	≈ 10	≈ 10			≈ 7	≈ 7	≈ 7	≈ 7	≈ 7	≈ 7	≈ 7	≈ 7	mA
at black level	≈ 60	≈ 80			≈ 50	≈ 50	≈ 50	≈ 50	≈ 45	≈ 50	≈ 50	≈ 50	mA
Focusing coil current	≈ 10	≈ 10			≈ 9	≈ 9	≈ 9	≈ 9	≈ 9	≈ 9	≈ 9	≈ 9	A
Drive power, peak sync., max.	15	25			10	20	10	20	10	20	20	20	W
Operating efficiency	42	41			45	45	45	45	46	45	45	45	%
Minimum efficiency	41	40			44	44	44	44	44	43	43	43	%

## Sound transmitter

Output power					5,5								kW
Beam voltage					19	23,5							kV
Beam current					0,7	0,55							A
Accelerator to cathode voltage					≈ 5,5	≈ 4,5							kV
Body current					≈ 15								mA
Focusing coil current					≈ 10								A
Drive power,													
channel 21					4								W
channel 45					2								W
channel 68					1								W
Bandwidth at -1 dB points					≥ 300								kHz
Operating efficiency					41								%

**CAUTION**

To limit X-radiation to officially permissible levels, fit collector radiation suppressor TE1182B and enclose the lower part of the magnet frame TE1188 in 1 mm sheet steel.

Keep away from the tube when it is in operation. R.F. leakage may be sufficient to cause bodily harm, particularly to the eyes. The risk is greater if the tube is functioning incorrectly.

**Notes**

1. When switching on the heater voltage, the heater current must never exceed a peak value of 70 A.
2. In case of a mains failure an interruption up to 30 s can be tolerated without new preheating. After min. 10 minutes of stand-by heating time at 4,5 V (black heat), the beam current may be switched on; the heater voltage must be increased to its nominal value of 5,5 V simultaneously.
3. To ensure that the klystron is always ready for operation, operate the ion getter pump at least every 6 months (preferably every 3 months) during storage. For details see klystron instruction manual.
4. In order to avoid corrosion of the cooling system, coolant water must be pure and deionized (resistivity min. 100 kΩ.cm).
5. The accelerator electrode voltage must not be positive with respect to the body (ground).
6. For cathode current (tolerance  $\pm 5\%$ ) versus accelerator-to-cathode voltage, see Fig. 4.
7. Connect the accelerator electrode to its supply (power supply or voltage divider) via a 10 kΩ resistor. A voltage divider for adjusting the cathode current should be dimensioned on the basis of an accelerator electrode current of max. 1,5 mA.
8. The drive power is defined as the power delivered to a matched load.
9. Value is not critical. It may be set in accordance with the vision klystron focusing coil current. Operation of one vision and one sound klystron focusing unit in series is permissible.
10. Standard CCIR-G: klystron tuned to frequency response according to the specification CCIR-G  
Standard CCIR-I: klystron tuned to frequency response according to the following diagram:

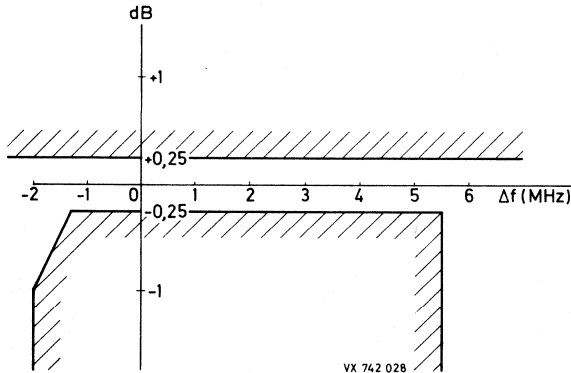

11. For sound operation cavity 3 needs no loading. Instead of load coupler TE1186 A/C use the blanking plate supplied with magnet frame TE1188.

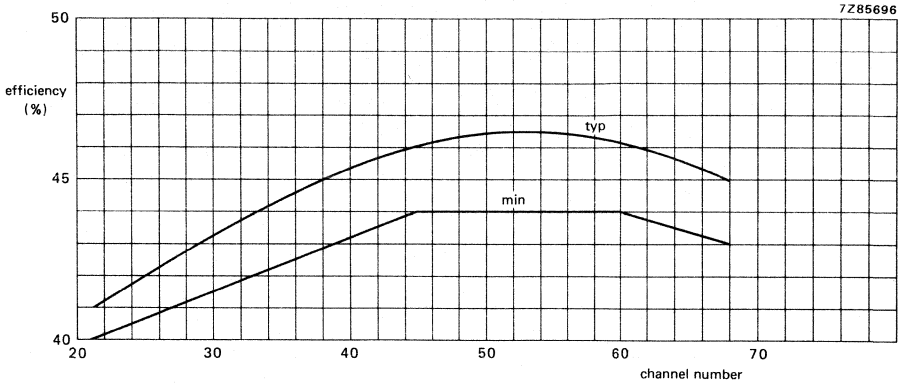

Fig. 5.

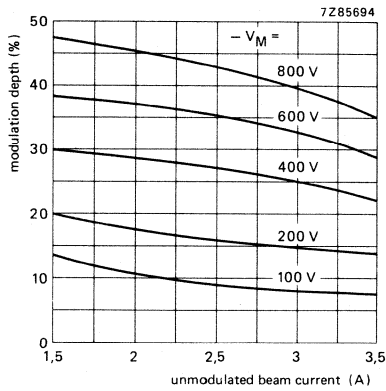

Fig. 6.





## DEVELOPMENT SAMPLE DATA

This information is derived from development samples made available for evaluation. It does not necessarily imply that the device will go into regular production.

YK1290  
YK1291  
YK1292

## U.H.F. POWER KLYSTRONS

Optionally vapour, vapour condensation, or water-cooled power klystrons in metal-ceramic construction for 55 kW vision transmitters and sound transmitters in the U.H.F. bands IV/V. The tubes have four external cavities, electromagnetic focusing and a high stability dispenser-type cathode. They contain non-intercepting annular beam control electrodes for low-voltage beam modulation.

### QUICK REFERENCE DATA

Frequency range	
YK1290	470 to 610 MHz
YK1291	590 to 720 MHz
YK1292	710 to 860 MHz
Cooling	vapour, vapour condensation, or water

**HEATING:** indirect by d.c.

notes; see page B129

Cathode	dispenser type	
Heater voltage	$V_f$	8,5 V*
Heater current	$I_f \approx$	22 to 27 A note 1
Cold heater resistance	$R_{fo} \approx$	30 m $\Omega$
Waiting time		note 2
from cold, $V_f = 0$ V	$t_w$ min.	300 s
from black heat, $V_f = 6$ V	$t_w$ min.	0 s

**FOCUSING:** electromagnetic

Focusing coil current		9 to 12 A
Resistance of focusing coils		
cold (20 °C)		7,2 to 9,5 $\Omega$
operating at an ambient temperature of 20 °C	$\leq$	11 $\Omega$

### BEAM CONTROL

The accelerator electrode voltage allows adjustment of the beam current between 0 and 100%.

### GETTER-ION PUMP SUPPLY

note 3

Pump voltage, no-load condition		3 to 4 kV
Internal resistance of supply		300 k $\Omega$

\* During operation the heater voltage may not fluctuate more than  $\pm 3\%$ .

YK1290  
YK1291  
YK1292

MECHANICAL DATA YK1290

Dimensions in mm

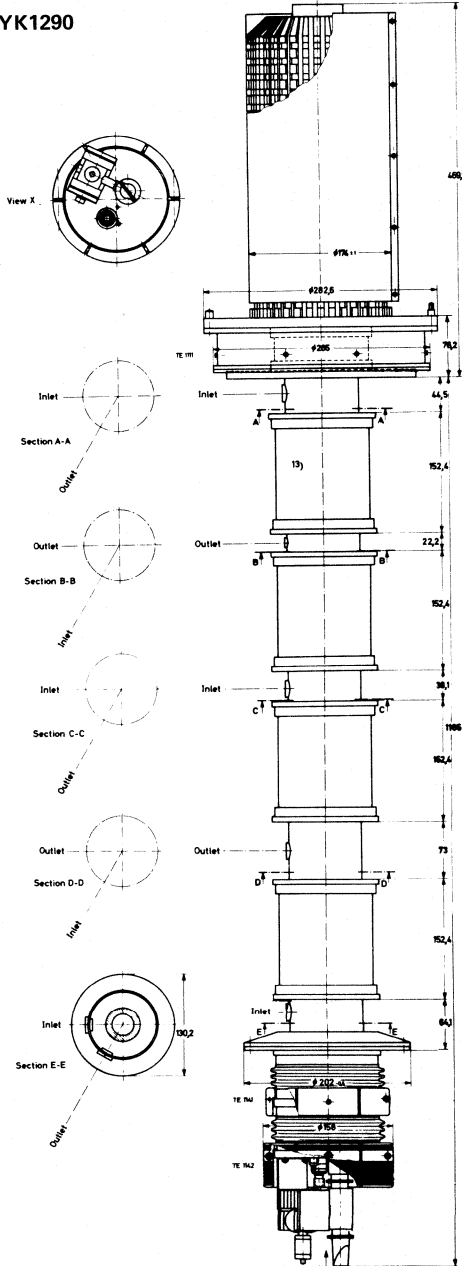

Fig. 1.

YK1291, YK1292

DEVELOPMENT SAMPLE DATA

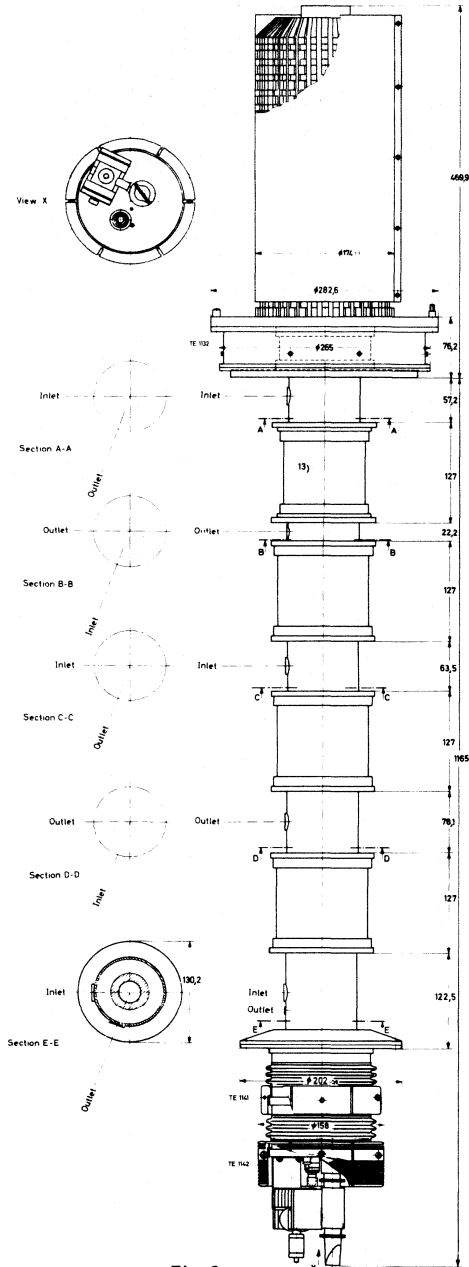
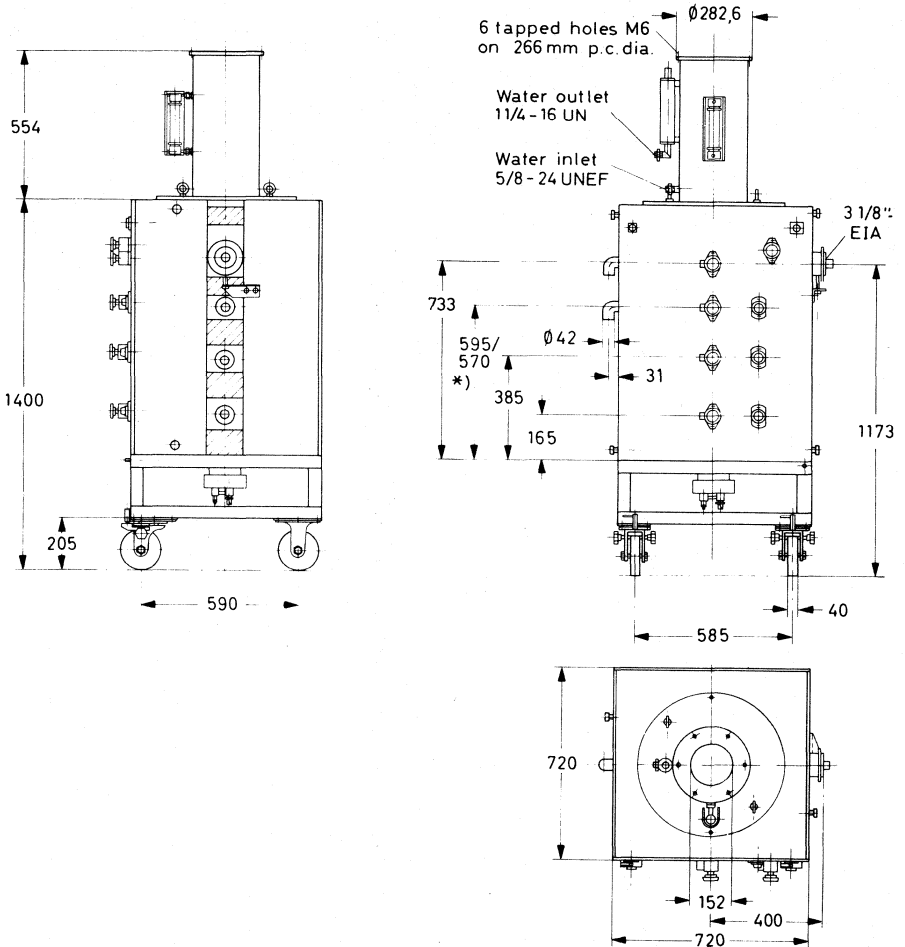

Fig. 2.

YK1290  
 YK1291  
 YK1292

Mechanical outlines of trolley



VX 722 642.B

Fig. 3.

\* YK1290 = 570 mm  
 YK1291/1292 = 595 mm

**COOLING**

Cathode socket and  
accelerator electrode

air;  $q \approx 0,15 \text{ m}^3/\text{min}$ ,  $t_i$  max.  $40 \text{ }^\circ\text{C}$

Collector

vapour (with boiler TE1110), note 4  
volume of water converted to steam:  $27 \text{ cm}^3/\text{min}$   
per kW collector dissipation resulting in  $43 \text{ l}/\text{min}$   
steam per kW collector dissipation  
water or vapour condensation (with cooler TE1194)  
 $q = 35$  to  $60 \text{ l}/\text{min}$ ,  $t_o$  max.  $80 \text{ }^\circ\text{C}$

Drift tubes

water; rate of flow to drift tubes and collector  
connected in series  $q \approx 9 \text{ l}/\text{min}$ ,  $t_i$  max.  $80 \text{ }^\circ\text{C}$ ,  
 $p_i = 200 \text{ kPa}$

Cavities 3 and 4

forced air;  $q = 1,5 \text{ m}^3/\text{min}$ ,  $p_i = 250 \text{ Pa}$ ,  $t_i$  max.  $45 \text{ }^\circ\text{C}$

**MASS (net)**

Tube

approx. 80 kg

Cavities

approx. 45 kg

Magnet frame with coils and boiler or cooler

approx. 855 kg

**MOUNTING**

Mounting position: vertical with collector up

To remove the tube from the magnet frame a total free height of 3,5 m, excluding hoist, is required.  
For detailed mounting and tuning instructions see klystron instruction manual, delivered with each tube.

**ACCESSORIES (note 5)**

Each tube is delivered with the following factory fitted accessories:

Collector radiation suppressor

Accelerator electrode ring

Cathode ring

Set of sealing rings

DEVELOPMENT SAMPLE DATA



YK1290

YK1291

YK1292

**A. Accessories to be ordered separately when replacing equivalent other brand types**

Magnet flux ring

TE1138

TE1138

Spark gap

TE1140

TE1140

Set of connectors (heater, cathode,  
acc. electrode, getter-ion pump)

TE1146

TE1146

TE1146

ACCESSORIES (continued)	YK1290	YK1291	YK1292
<b>B. Accessories required for first equipment</b>			
Magnet flux ring	TE1138	TE1138	TE1138
Spark gap	TE1140	TE1140	TE1140
Set of connectors (heater, cathode, acc. electrode, getter-ion pump)	TE1146	TE1146	TE1146
Extension pipes for drift tubes	6 x TE1133A 2 x TE1133B	6 x TE1133A 2 x TE1133B	6 x TE1133A 2 x TE1133B
Water interconnecting pipes between drift tubes			
T <sub>1</sub> - T <sub>2</sub>	TE1134A	TE1135A	TE1135A
T <sub>2</sub> - T <sub>3</sub>	TE1134B	TE1135B	TE1135B
T <sub>3</sub> - T <sub>4</sub>	TE1134C	TE1135C	TE1135C
T <sub>4</sub> - T <sub>5</sub>	TE1134D	TE1135D	TE1135D
Flexible water pipes			
between tube and boiler for vapour cooling	TE1145A	TE1145A	TE1145A
between frame and tube	TE1145B	TE1145B	TE1145B
tube outlet for water cooling	TE1145C	TE1145C	TE1145C
Boiler for vapour cooling or Cooler for water cooling	TE1110 TE1194	TE1110 TE1194	TE1110 TE1194
Cavities	3 x TE1121A 1 x TE1121D	3 x TE1098A 1 x TE1098D	3 x TE1191A 1 x TE1191B
Input coupler	TE1122A	TE1102	TE1102
Load coupler for cavities 2 and 3	2 x TE1122B	2 x TE1102	2 x TE1102
Blanking plates	3 x TE1157	3 x TE1157	3 x TE1157
Output coupler for cavity 4	TE1123	TE1105	TE1196
Arc detector	TE1107	TE1107	TE1107
Magnet frame with coils	TE1108	TE1108	TE1108
Tool set	TE1137	TE1137	TE1137
<b>C. Spare and optional parts</b>			
Collector radiation suppressor	TE1111	TE1132	TE1195
Accelerator electrode ring	TE1141	TE1141	TE1141
Cathode ring	TE1142	TE1142	TE1142
Set of connectors (heater, cathode, acc. electrode, getter-ion pump)	TE1146	TE1146	TE1146
Set of sealing rings	TE1147	TE1147	TE1147
Water protection shield	TE1139	TE1139	TE1139
Recommended circulators			
470 to 600 MHz	2722 162 01551 (T100/IV-N)		
600 to 800 MHz	2722 162 01561 (T100/V-N)		
790 to 1000 MHz	2722 162 03261 (T100/V-3-N)		

**LIMITING VALUES** (Absolute Maximum rating system)

Heater voltage	max.	9,5 V	
Beam voltage	max.	28 kV	
Cold cathode voltage	max.	-30 kV	
Beam current	max.	7 A	
Body current	max.	150 mA	
Accelerator electrode current	max.	6 mA	note 7
Collector dissipation	max.	150 kW	
Load v.s.w.r.	max.	1,5	
Temperature of tube envelope	max.	175 °C	
Static pressure	max.	600 kPa	note 6
Modulation electrode voltage	max.	1000 V	

**CAUTION – HEALTH HAZARD****1. X-radiation**

Correct operation of the tube can be guaranteed only if a set of accessories, approved by the tube manufacturer, is used.

The operating tube generates X-rays which can penetrate the ceramic parts of the tube envelope. In order to reduce the radiation at any accessible points to an officially admissible, non-dangerous level the tube must be shielded and any possible radiation path must be blocked by at least 1 mm of brass or an equivalent portion of non-magnetic X-ray absorbing material. The proper use of our accessory parts will provide the necessary shielding.

**2. R.F. radiation**

R.F. power may be emitted not only through the normal output coupling but also through other apertures (for example r.f. leaks). This r.f. power may be sufficiently intense to cause danger to the human body, particularly to the eyes. Such radiation may be increased if the tube is functioning incorrectly.

**Instruction manual**

For detailed mounting and tuning instructions see klystron instruction manual, delivered with each tube.



**TYPICAL OPERATING CONDITIONS**

As 55 kW/40 kW vision transmitter (standard: CCIR + G, RTMA-M and RTMA-M\*)

	YK1290/YK1291			YK1292			
Output power, peak sync.	58	58	45	58	58	45 kW	
Beam voltage	-22,5	-26	-22,5	-23,5	-27	-25,5 kV	
Beam current	6,4	4,85	3,8	5,9	4,9	3,9 A	note 8
Accelerator to cathode voltage	22,5	16,5	16	21	17	16 kV	
Body current							
without drive	15	15	15	15	15	15 mA	
at 58/45 kW peak sync., black level	40	40	40	40	40	40 mA	
Focusing coil current	10,5	10,5	9,5	10,5	10,5	10 A	
Drive power, peak sync.							
YK1290 - channel 21	10	6	6	-	-	- W	note 9
channel 38	7	4	4	-	-	- W	note 9
YK1291 - channel 37	7	4	4	-	-	- W	note 9
channel 51	5	3	3	-	-	- W	note 9
YK1292	-	-	-	2	2	2 W	note 9
Bandwidth at -1 dB points	8	8	8	8	8	8 MHz	note 10
Differential gain	75	70	70	70	70	70 %	note 11
Differential phase	6	10	10	10	10	10 deg	note 11
Linearity	65	60	60	60	60	60 %	note 12
Operating efficiency	40	46	46,5	42	44	45 %	
Saturation output power	63	60	46,5	60	60	46,5 kW	
Saturation efficiency	44	47,5	48	43	45	46,5 %	
<b>As 11/8 kW FM sound transmitter</b>							
Output power	12	12	9	12	12	9 kW	
Beam voltage	-22,5	-26	-25,5	-23,5	-27	-25,5 kV	
Beam current	1,5	1,2	1,3	1,5	1,2	1,3 A	
Accelerator cathode voltage	8,5	7,5	≈ 8	8,5	7,5	≈ 8 kV	note 14
Focusing coil current	9	9	9	9	9	9 A	
Drive power	1,5	1,5	1,5	1,5	1,5	1,5 W	note 9
Bandwidth at -1 dB points	1	1	1	1	1	1 MHz	



**Notes**

1. When switching on the heater voltage, the heater current must never exceed a peak value of 65 A.
2. In cases of a mains failure an interruption up to 30 s can be tolerated without new preheating. After min. 10 minutes of stand-by heating time at 6,0 V, the beam current may be switched on; the heater voltage must be increased to its nominal value of 8,5 V simultaneously. Operation under stand-by conditions is restricted to continuous periods of 2 weeks at a time. Stand-by periods should be separated by similar periods of rest or full operation.
3. To ensure that the klystron is ready for immediate operation the getter-ion pump should be operated at least every 6 months during storage, 3 months being recommended. For details see klystron instruction manual.
4. In order to avoid corrosion of the cooling system, pure deionised water must be used as the coolant (resistivity min. 100 k $\Omega$ .cm).
5. Correct operation of the tube can be guaranteed only if a set of accessories, approved by the tube manufacturer, is used. The operating tubes generates X-rays which can penetrate the ceramic parts of the tube envelope. In order to reduce the radiation at any accessible points to an officially admissible, non-dangerous level the tube must be shielded and any possible radiation path must be blocked by at least 1 mm of brass or an equivalent portion of non-magnetic X-ray absorbing material. The proper use of our accessory parts will provide the necessary shielding.
6. Static pressure in the body-cooling system and in the water-cooling jacket TE1194.
7. The accelerator electrode voltage must not be positive with respect to the body (ground).
8. If the accelerator electrode is connected to the body (ground) via a 10 k $\Omega$  resistor, the beam current is within  $\pm$  5% of the value given in the graph of Fig. 4.
9. The drive power is defined as the power delivered to a matched load.
10. Varying the input level between black and white at any sideband frequency within this bandwidth will not cause a variation of the peak sync. output power exceeding 0,5 dB.
11. Measured with a sawtooth signal from black level to peak white occurring at each line and super-imposed colour subcarrier with a 10% peak to peak amplitude.
12. Measured with a ten-step staircase signal from black level to peak white occurring at each line.
13. Where the ceramic of the output section is beryllium oxide, this is indicated on the tube. The dust of beryllium oxide is toxic. For the disposal of burnt-out tubes observe government regulations.
14. For adjusting the beam current in sound operation a voltage divider should be dimensioned according to an accelerator electrode current of max. 1,5 mA.



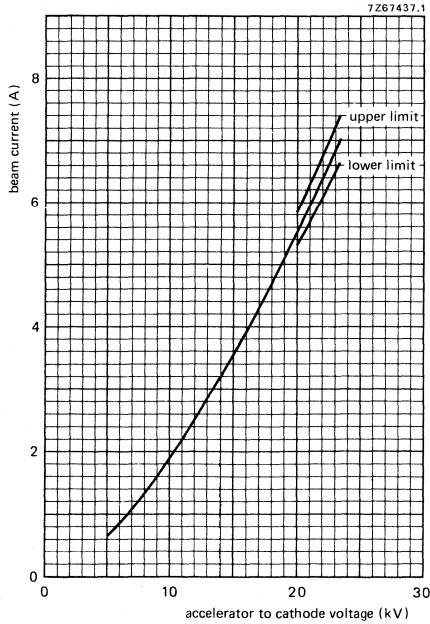

Fig. 4.

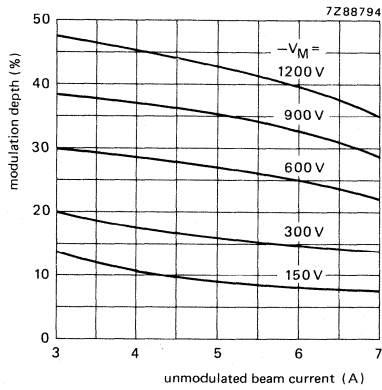

Fig. 5 Parameter: modulation voltage  $-V_M$   
(with respect to cathode).

## DEVELOPMENT SAMPLE DATA

This information is derived from development samples made available for evaluation. It does not necessarily imply that the device will go into regular production.

YK1295  
YK1296  
YK1297

## U.H.F. POWER KLYSTRONS

Optionally vapour, vapour condensation, or water-cooled power klystrons in metal-ceramic construction for 55 kW vision transmitters and sound transmitters in the U.H.F. bands IV/V. The tubes have four external cavities, electromagnetic focusing and a high stability dispenser-type cathode. They contain non-intercepting annular beam control electrodes for low-voltage beam modulation.

### QUICK REFERENCE DATA

Frequency range	
YK1295	470 to 610 MHz
YK1296	590 to 720 MHz
YK1297	710 to 860 MHz
Cooling	vapour, vapour condensation, or water

### HEATING: indirect by d.c.

notes; see page B139

Cathode	dispenser type		
Heater voltage	$V_f$	8,5 V*	
Heater current	$I_f \approx$	22 to 27 A	note 1
Cold heater resistance	$R_{fo} \approx$	30 m $\Omega$	
Waiting time			note 2
from cold, $V_f = 0$ V	$t_w$ min.	300 s	
from black heat, $V_f = 6$ V	$t_w$ min.	0 s	

### FOCUSING: electromagnetic

Focusing coil current	9 to 12 A
Resistance of focusing coils	
cold (20 °C)	7,2 to 9,5 $\Omega$
operating at an ambient temperature of 20 °C	$\leq$ 11 $\Omega$

### BEAM CONTROL

The klystrons contain a non-intercepting annular beam control electrode for low-voltage beam modulation. See Fig. 5.

The accelerator electrode voltage allows adjustment of the beam current between 0 and 100%.

### GETTER—ION PUMP SUPPLY

note 3

Pump voltage, no-load condition	3 to 4 kV
Internal resistance of supply	300 k $\Omega$

\* During operation the heater voltage may not fluctuate more than  $\pm 3\%$ .

MECHANICAL DATA YK1295

Dimensions in mm

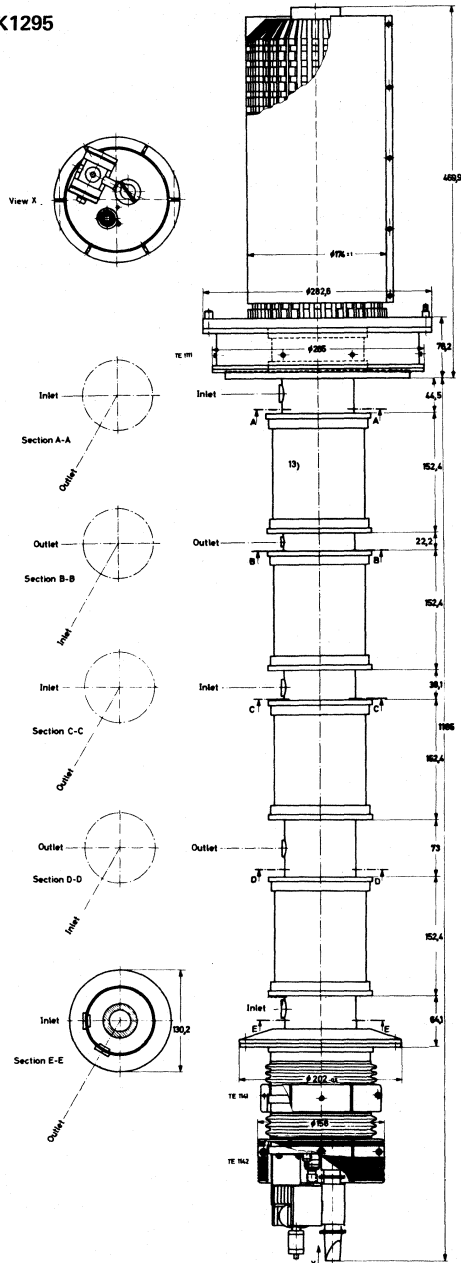

Fig. 1.

YK1296, YK1297

DEVELOPMENT SAMPLE DATA

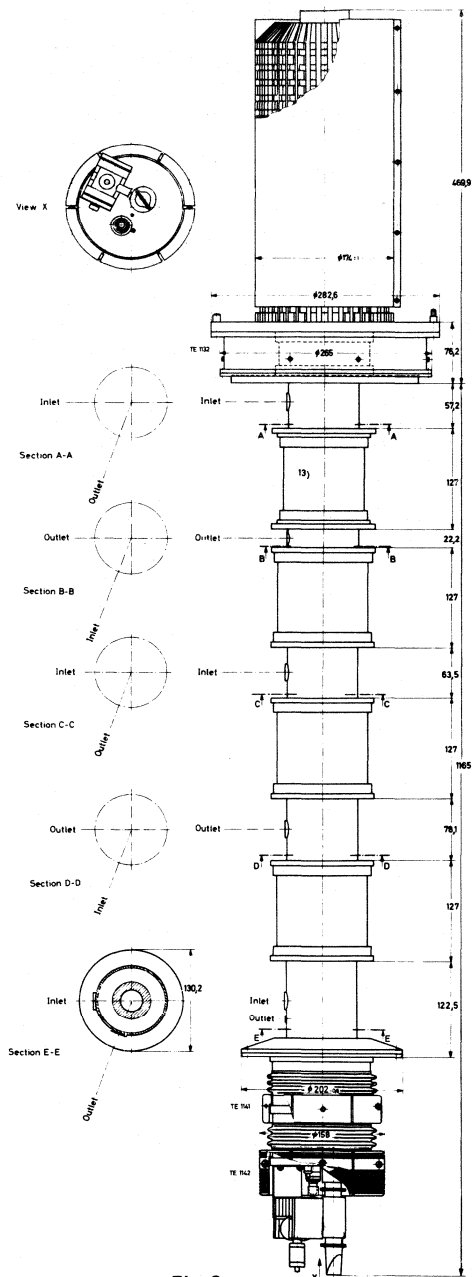

Fig. 2.

YK1295  
 YK1296  
 YK1297

Mechanical outlines of trolley

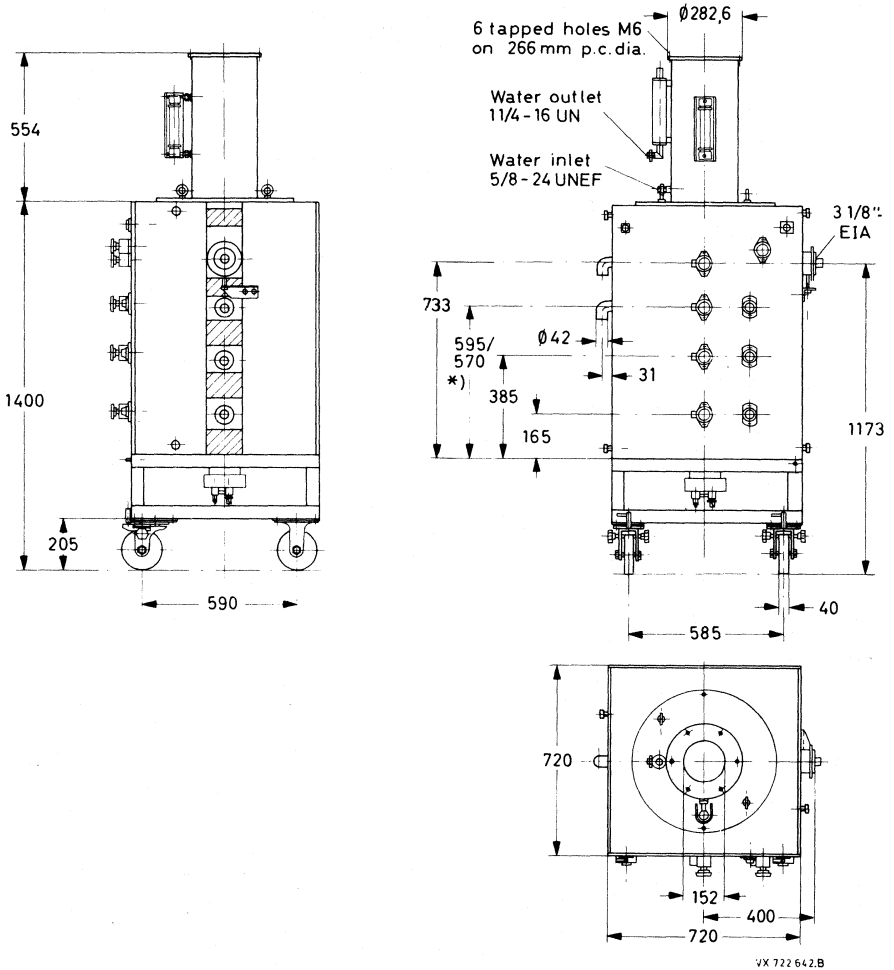

Fig. 3.

\* YK1295 = 570 mm  
 YK1296/1297 = 595 mm

**COOLING**

Cathode socket and  
accelerator electrode  
Collector

air;  $q \approx 0,15 \text{ m}^3/\text{min}$ ,  $t_i$  max.  $40 \text{ }^\circ\text{C}$   
vapour (with boiler TE1110), note 4  
volume of water converted to steam:  $27 \text{ cm}^3/\text{min}$   
per kW collector dissipation resulting in  $43 \text{ l}/\text{min}$   
steam per kW collector dissipation  
water or vapour condensation (with cooler TE1194)  
 $q = 35 \text{ to } 60 \text{ l}/\text{min}$ ,  $t_o$  max.  $80 \text{ }^\circ\text{C}$

Drift tubes

water; rate of flow to drift tubes and collector  
connected in series  $q \approx 9 \text{ l}/\text{min}$ ,  $t_i$  max.  $80 \text{ }^\circ\text{C}$ ,  
 $p_i = 200 \text{ kPa}$

Cavities 3 and 4

forced air;  $q = 1,5 \text{ m}^3/\text{min}$ ,  $p_i = 250 \text{ Pa}$ ,  $t_i$  max.  $45 \text{ }^\circ\text{C}$

**MASS (net)**

Tube  
Cavities  
Magnet frame with coils and boiler or cooler

approx. 80 kg  
approx. 45 kg  
approx. 855 kg

**MOUNTING**

Mounting position: vertical with collector up

To remove the tube from the magnet frame a total free height of 3,5 m, excluding hoist, is required. For detailed mounting and tuning instructions see klystron instruction manual, delivered with each tube.

**ACCESSORIES (note 5)**

Each tube is delivered with the following factory fitted accessories:

- Collector radiation suppressor
- Accelerator electrode ring
- Cathode ring
- Set of sealing rings

	YK1295	YK1296	YK1297
--	--------	--------	--------

**A. Accessories to be ordered separately when replacing equivalent other brand types**

Magnet flux ring	TE1138	TE1138	
Spark gap	TE1140	TE1140	
Set of connectors (heater, cathode, acc. electrode, getter-ion pump)	TE1146	TE1146	TE1146

DEVELOPMENT I SAMPLE DATA



ACCESSORIES (continued)	YK1295	YK1296	YK1297
<b>B. Accessories required for first equipment</b>			
Magnet flux ring	TE1138	TE1138	TE1138
Spark gap	TE1140	TE1140	TE1140
Set of connectors (heater, cathode, acc. electrode, getter-ion pump)	TE1146	TE1146	TE1146
Extension pipes for drift tubes	6 x TE1133A 2 x TE1133B	6 x TE1133A 2 x TE1133B	6 x TE1133A 2 x TE1133B
Water interconnecting pipes between drift tubes			
T <sub>1</sub> - T <sub>2</sub>	TE1134A	TE1135A	TE1135A
T <sub>2</sub> - T <sub>3</sub>	TE1134B	TE1135B	TE1135B
T <sub>3</sub> - T <sub>4</sub>	TE1134C	TE1135C	TE1135C
T <sub>4</sub> - T <sub>5</sub>	TE1134D	TE1135D	TE1135D
Flexible water pipes between tube and boiler for vapour cooling			
between frame and tube	TE1145A	TE1145A	TE1145A
tube outlet for water cooling	TE1145B TE1145C	TE1145B TE1145C	TE1145B TE1145C
Boiler for vapour cooling or Cooler for water cooling	TE1110 TE1194	TE1110 TE1194	TE1110 TE1194
Cavities	3 x TE1121A 1 x TE1121D	3 x TE1098A 1 x TE1098D	3 x TE1191A 1 x TE1191B
Input coupler	TE1122A	TE1102	TE1102
Load coupler for cavities 2 and 3	2 x TE1122B	2 x TE1102	2 x TE1102
Blanking plates	3 x TE1157	3 x TE1157	3 x TE1157
Output coupler for cavity 4	TE1123	TE1105	TE1196
Arc detector	TE1107	TE1107	TE1107
Magnet frame with coils	TE1108	TE1108	TE1108
Tool set	TE1137	TE1137	TE1137
<b>C. Spare and optional parts</b>			
Collector radiation suppressor	TE1111	TE1132	TE1195
Accelerator electrode ring	TE1141	TE1141	TE1141
Cathode ring	TE1142	TE1142	TE1142
Set of connectors (heater, cathode, acc. electrode, getter-ion pump)	TE1146	TE1146	TE1146
Set of sealing rings	TE1147	TE1147	TE1147
Water protection shield	TE1139	TE1139	TE1139
Recommended circulators			
470 to 600 MHz	2722 162 01551 (T100/IV-N)		
600 to 800 MHz	2722 162 01561 (T100/V-N)		
790 to 1000 MHz	2722 162 03261 (T100/V-3-N)		



**LIMITING VALUES** (Absolute maximum rating system)

Heater voltage	max.	9,5 V	
Beam voltage	max.	28 kV	
Cold cathode voltage	max.	-30 kV	
Beam current	max.	7 A	
Body current	max.	150 mA	
Accelerator electrode current	max.	6 mA	note 7
Collector dissipation	max.	150 kW	
Load v.s.w.r.	max.	1,5	
Temperature of tube envelope	max.	175 °C	
Static pressure	max.	600 kPa	note 6
Modulation electrode voltage	max.	1000 V	

**CAUTION – HEALTH HAZARD****1. X-radiation**

Correct operation of the tube can be guaranteed only if a set of accessories, approved by the tube manufacturer, is used.

The operating tube generates X-rays which can penetrate the ceramic parts of the tube envelope. In order to reduce the radiation at any accessible points to an officially admissible, non-dangerous level the tube must be shielded and any possible radiation path must be blocked by at least 1 mm of brass or an equivalent portion of non-magnetic X-ray absorbing material. The proper use of our accessory parts will provide the necessary shielding.

**2. R.F. radiation**

R.F. power may be emitted not only through the normal output coupling but also through other apertures (for example r.f. leaks). This r.f. power may be sufficiently intense to cause danger to the human body, particularly to the eyes. Such radiation may be increased if the tube is functioning incorrectly.

**Instruction manual**

For detailed mounting and tuning instructions see klystron instruction manual, delivered with each tube.



**TYPICAL OPERATING CONDITIONS**

As 55 kW/40 kW vision transmitter (standards: CCIR + G, RTMA-M and RTMA-M\*)

	YK1295/YK1296			YK1297			
Output power, peak sync.	58	58	45	58	58	45 kW	
Beam voltage	-22,5	-26	-22,5	-23,5	-27	-25,5 kV	
Beam current	6,4	4,85	3,8	5,9	4,9	3,9 A	note 8
Accelerator to cathode voltage	22,5	16,5	16	21	17	16 kV	
Body current							
without drive	15	15	15	15	15	15 mA	
at 58/45 kW peak sync., black level	40	40	40	40	40	40 mA	
Focusing coil current	10,5	10,5	9,5	10,5	10,5	10 A	
Drive power, peak sync.							
YK1295 - channel 21	10	6	6	-	-	- W	note 9
channel 38	7	4	4	-	-	- W	note 9
YK1296 - channel 37	7	4	4	-	-	- W	note 9
channel 51	5	3	3	-	-	- W	note 9
YK1297	-	-	-	2	2	2 W	note 9
Bandwidth at -1 dB points	8	8	8	8	8	8 MHz	note 10
Differential gain	75	70	70	70	70	70 %	note 11
Differential phase	6	10	10	10	10	10 deg	note 11
Linearity	65	60	60	60	60	60 %	note 12
Operating efficiency	40	46	46,5	42	44	45 %	
Saturation output power	63	60	46,5	60	60	46,5 kW	
Saturation efficiency	44	47,5	48	43	45	46,5 %	
<b>As 11/8 kW FM sound transmitter</b>							
Output power	12	12	9	12	12	9 kW	
Beam voltage	-22,5	-26	-25,5	-23,5	-27	-25,5 kV	
Beam current	1,5	1,2	1,3	1,5	1,2	1,3 A	
Accelerator cathode voltage	8,5	7,5	≈ 8	8,5	7,5	≈ 8 kV	note 14
Focusing coil current	9	9	9	9	9	9 A	
Drive power	1,5	1,5	1,5	1,5	1,5	1,5 W	note 9
Bandwidth at -1 dB points	1	1	1	1	1	1 MHz	

## Notes

1. When switching on the heater voltage, the heater current must never exceed a peak value of 65 A.
2. In cases of a mains failure an interruption up to 30 s can be tolerated without new preheating. After min. 10 minutes of stand-by heating time at 6,0 V, the beam current may be switched on; the heater voltage must be increased to its nominal value of 8,5 V simultaneously. Operation under stand-by conditions is restricted to continuous periods of 2 weeks at a time. Stand-by periods should be separated by similar periods of rest or full operation.
3. To ensure that the klystron is ready for immediate operation the getter-ion pump should be operated at least every 6 months during storage, 3 months being recommended. For details see klystron instruction manual.
4. In order to avoid corrosion of the cooling system, pure deionised water must be used as the coolant (resistivity min. 100 k $\Omega$ .cm).
5. Correct operation of the tube can be guaranteed only if a set of accessories, approved by the tube manufacturer, is used. The operating tubes generates X-rays which can penetrate the ceramic parts of the tube envelope. In order to reduce the radiation at any accessible points to an officially admissible, non-dangerous level the tube must be shielded and any possible radiation path must be blocked by at least 1 mm of brass or an equivalent portion of non-magnetic X-ray absorbing material. The proper use of our accessory parts will provide the necessary shielding.
6. Static pressure in the body-cooling system and in the water-cooling jacket TE1194.
7. The accelerator electrode voltage must not be positive with respect to the body (ground).
8. If the accelerator electrode is connected to the body (ground) via a 10 k $\Omega$  resistor, the beam current is within  $\pm 5\%$  of the value given in the graph of Fig. 4.
9. The drive power is defined as the power delivered to a matched load.
10. Varying the input level between black and white at any sideband frequency within this bandwidth will not cause a variation of the peak sync. output power exceeding 0,5 dB.
11. Measured with a sawtooth signal from black level to peak white occurring at each line and superimposed colour subcarrier with a 10% peak to peak amplitude.
12. Measured with a ten-step staircase signal from black level to peak white occurring at each line.
13. Where the ceramic of the output section is beryllium oxide, this is indicated on the tube. The dust of beryllium oxide is toxic. For the disposal of burnt-out tubes observe government regulations.
14. For adjusting the beam current in sound operation a voltage divider should be dimensioned according to an accelerator electrode current of max. 1,5 mA.



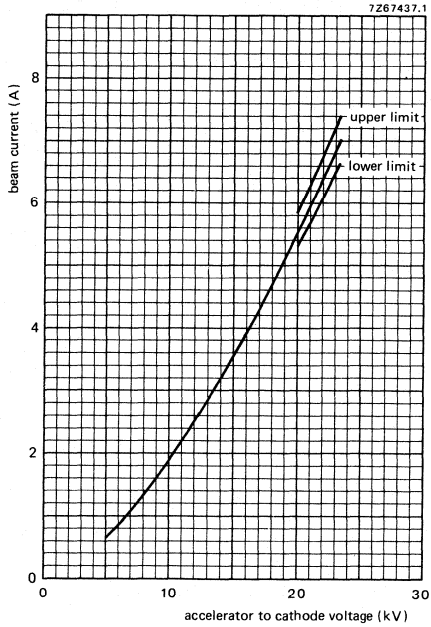

Fig. 4.

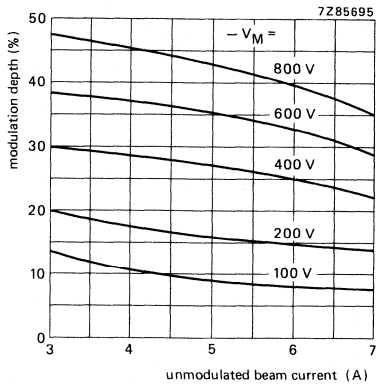

Fig. 5 Parameter: modulation voltage  $-V_M$  (with respect to cathode).

## CONTINUOUS-WAVE HIGH POWER KLYSTRON

Water cooled, high efficiency, fixed frequency, continuous-wave high power klystron in metal-ceramic construction, for use in scientific and industrial applications. The tube has internal cavities, solenoid focusing, beam control by accelerator anode and a high stability dispenser-type cathode.

### QUICK REFERENCE DATA

Centre frequency (fixed tuned)	499,7 MHz
Bandwidth at saturation (−1 dB points)	2 MHz
Output power	500 to 600 kW
Cooling	water

**HEATING:** indirect by d.c.

notes: see page B147  
dispenser type

Cathode

		min.	typ.	max.	
Heater voltage	$V_f$	20	25	30	V
Heater current	$I_f$	20	25	30	A notes 1, 2
Cold heater resistance	$R_{f0}$	—	100	—	$m\Omega$
Waiting time	$t_w$	15	—	—	minutes

**FOCUSING:** electromagnetic

Solenoid current		5	9	15	A
Solenoid voltage		—	130	200	V
Solenoid resistance		—	14	—	$\Omega$

**GETTER-ION PUMP SUPPLY**

Operating voltage		3	3,3	4	kV
Operating current		—	$10^{-3}$	80	mA
Internal resistance of power supply		25	—	—	$k\Omega$

MECHANICAL DATA

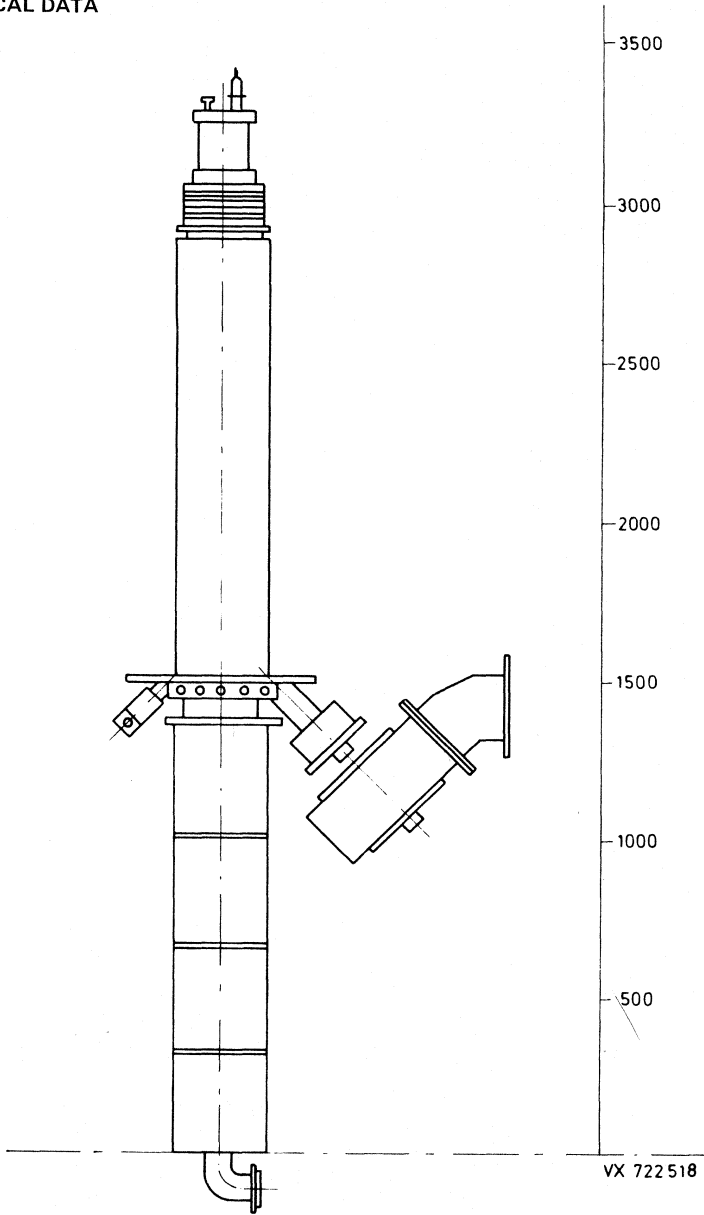

Fig. 1.

Tube mounted in the mounting frame with solenoid.

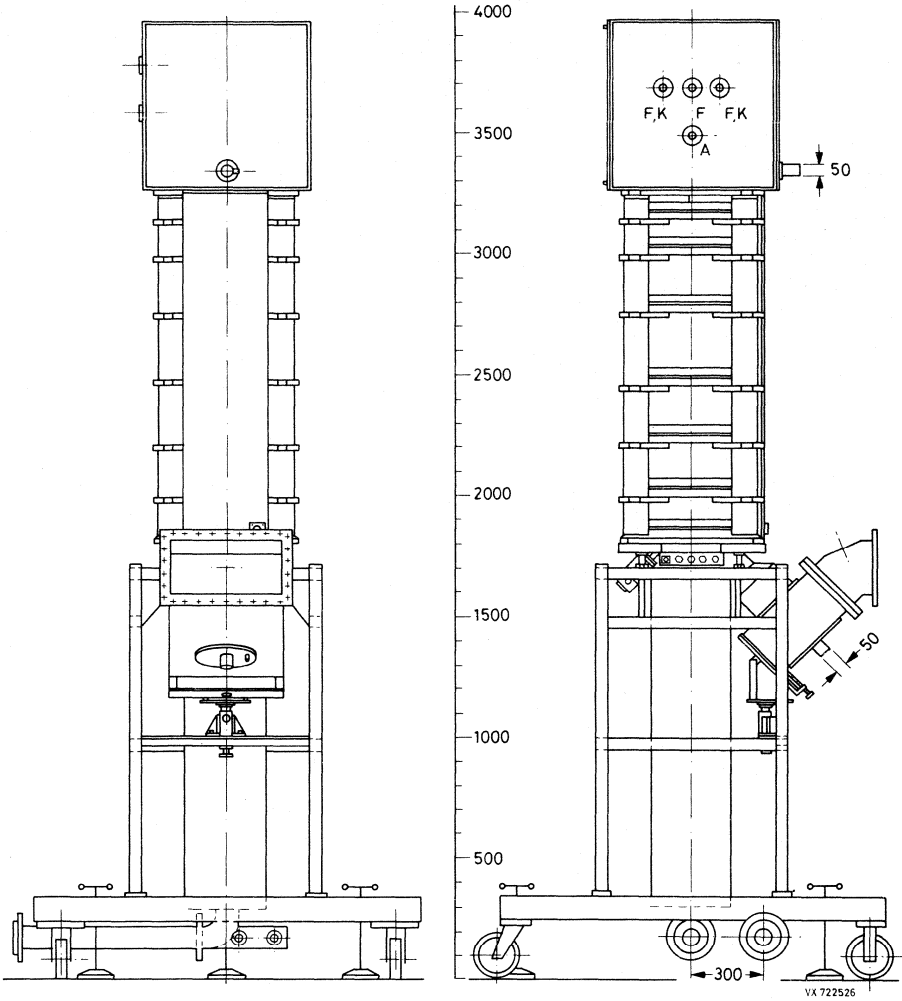

Fig. 2.

	min.	typ.	max.		
<b>Cooling</b>					
Collector					
demineralized or distilled water					
with 10% stabilized glycol added	850	900	1000	l/min	note 3
pressure drop	230	330	450	kPa	
Body circuit I					
demineralized or distilled water					
with 10% stabilized glycol added	7	10	—	l/min	note 3
pressure drop	—	330	—	kPa	
Body circuit II					
demineralized or distilled water					
with 10% stabilized glycol added	14	20	—	l/min	note 3
pressure drop	—	330	—	kPa	
Cathode socket and accelerator anode					
air	2	—	—	m <sup>3</sup> /min	
pressure drop	—	—	500	Pa	
Output window					
air	2,5	—	—	m <sup>3</sup> /min	
pressure drop	—	4	6	kPa	
Inlet water temperature	—	—	+ 50	°C	
Inlet air temperature	—	—	+ 45	°C	
<b>Accessories</b>	mounting frame including solenoid				
<b>Mass</b>					
Net mass YK1300	400 kg				
Mounting frame with solenoid	800 kg				
Capability of hoist	min. 600 kg				
<b>Dimensions</b>					
Tube and mounting frame	see drawings				
Required ground clearance for lifting hoist	min. 580 cm				
<b>Mounting</b>	vertical, cathode up				
<b>R.F. connectors</b>					
Input	N-type, female				
Output	waveguide R5 (WR1800) mating flange UDR5				





**ACCESSORIES****A. Separate parts**

Collector water cooling jacket	TE 1170	
Coax/waveguide transition, WR1800 with 45° knee	TE 1164	
Window cooling air inlet	TE 1165	
Accelerator anode ring	TE 1173	
Cathode ring	TE 1174 A	
Corona protector	TE 1174 B	

note 4

**B. Operational parts for first equipment**

H.V. connection unit with R3 sockets	TE 1163	note 5
Klystron trolley with waveguide support	TE 1167	
Focusing coil unit	TE 1166	
Water outlet collecting tube	TE 1168	
Interconnecting water hoses	4x TE 1169	
Connection cables, heater/cathode	2x TE 1171 A	
heater	TE 1171 B	
accelerator anode	TE 1171 C	

**C. Optional parts**

H.V. socket R3	4x TE 1158	note 6
H.V. cable with R3 plugs, length 6 m	4x TE 1159	note 6
length 9 m	4x TE 1160	note 6
H.V. dummy plug R3	4x TE 1161	note 6
Yoke for lifting TE 1166 and TE 1163	TE 1175	note 11
Yoke for lifting and turning a klystron from any position	TE 1176	note 11
Supporting frame for storage and any movement of burnt-out or spare klystrons in any position other than vertical	TE 1177	note 11
Trolley for transportation of a klystron in horizontal position without lifting gear	TE 1178	note 12



**LIMITING VALUES** (Absolute maximum rating system)

Heater voltage				
Heater current				} max. 10% above specified values
Cathode voltage	max.	-65	kV	
Cold cathode voltage	max.	-70	kV	
Cathode current	max.	20	A	
Accelerator anode voltage	min.	0	V	} note 7
	max.	-65	kV	
Cold accelerator anode voltage	max.	-70	kV	
Accelerator anode current	max.	5	mA	
Collector dissipation	max.	850	kW	} note 8
Dissipation body circuit I	max.	10	kW	
Dissipation body circuit II	max.	20	kW	
Load VSWR	max.	1,1		} note 9

**TYPICAL OPERATING CONDITIONS**

**500 kW operation into matched load**

	min.	typ.	max.	
Cathode voltage	-	-58	-60	} note 10
Cathode current	-	14,4	18,6	
Input power	-	835	-	kW
Accelerator anode voltage	-1	-	-	kV
Accelerator anode current	-	1	5	mA
C.W. output power, VSWR ≤ 1,1	-	500	-	kW
Collector dissipation	-	335	-	kW
Efficiency	58	60	-	%
C.W. drive power	-	25	50	W

**600 kW operation into matched load**

Cathode voltage	-	-58	-62	kV
Cathode current	-	18,6	19	A
Input power	-	1,08	1,1	MW
Accelerator anode voltage	-1	-	-	kV
Accelerator anode current	-	1	5	mA
C.W. output power, VSWR ≤ 1,1	570	600	-	kW
Collector dissipation	-	480	530	kW
Efficiency	52	56	-	%
C.W. drive power	-	25	50	W

## Notes

1. When switching on the heater voltage, the heater current must never exceed a peak value of 65 A.
2. Required values are given with each tube.
3. For further recommendations please contact the tube manufacturer.
4. Separate parts, matched individually to each tube, to be delivered together with each tube and to be returned together with each burnt-out tube.
5. R3 sockets are only usable together with optional accessories TE 1159 and TE 1160.
6. Cable with R3 plugs on each end, to be fed into the R3 sockets of the H.V. connection unit TE 1163 and into R3 sockets TE 1158 applied to the power supply. Dummy plugs are provided for cable termination on H.V. test of the cable set.
7. The accelerator anode voltage may never become positive with respect to the body (ground).
8. 1100 kW up to 10 s.
9. For reflections exceeding this value please contact the tube manufacturer.
10. Maximum values will not occur simultaneously.
11. Parts are needed for all handling operations at the site and are to be ordered once for the site.
12. Free option.

**INSTALLATION AND OPERATION REQUIREMENTS****A. Required interlocks**

1. Fast switch-off of the drive power within 30 ms has to be done if the arc detector and/or r.f. reflection indicator is activated. An arc detector must be provided at the knee of the output waveguide.
2. A fast switch-off of the beam supply has to be provided when one of the following situations occur:
  - a) the beam current increases rapidly,
  - b) the solenoid current deviates by more than  $\pm 5\%$  from the adjusted value.

The switching sensors and the discharge facilities for the power supply must be designed so that a copper wire of 0,35 mm diameter, connected to the power supply instead of the klystron (length approx. 1 cm/kV), will not be destroyed, if the full operating voltage is switched on and applied to the wire.
3. The mains for the beam power supply has to be switched off within 100 ms when one of the following situations occur:
  - a) the collector temperature monitor (with internal thermocouple) is activated (switch-off value adjustable between 30 and 60 K above the water inlet temperature),
  - b) the monitored temperature differences between inlet and outlet in the collector and/or body cooling circuits are too high;
 

max. values permitted: collector	$\Delta \theta = 14 \text{ K}$
body circuit I	$\Delta \theta = 30 \text{ K}$
body circuit II	$\Delta \theta = 30 \text{ K}$
  - c) the beam current either exceeds the limiting value or increases by more than 30% or max. 2 A above the adjusted value,
  - d) the water flow of the collector and body cooling circuits decreases below the required minimum value,
  - e) the air flow for the r.f. window and cathode cooling decreases below the required minimum value.

Restarting is not allowed within 10 s of any interruption.



**B. Switching-on and off sequence**

## Switching-on sequence

1. Cathode cooling on.
2. Getter-ion pump supply on.
3. Check that the pump current is  $< 4$  mA.
4. Heater voltage supply on.
5. Wait for preheating time (min. 15 minutes)
6. Cooling air r.f. window on.
7. Cooling body circuits I and II on.
8. Collector cooling supply on.
9. Solenoid current supply on.
10. Check that the heater current has reached the adjusted value  $\pm 2$  A.
11. Beam supply on.

## Switching-off sequence

1. Beam voltage supply off.
2. All other supplies and cooling circuits off.

**c. Radiation dangers***R.F. radiation*

R.F. power may be emitted not only through the normal output coupling but also through other apertures (for example, r.f. leaks). This r.f. power may be sufficiently intense to cause danger to the human body, particularly to the eyes. Such radiation may be increased if the tube is functioning incorrectly.

*X-radiation*

A highly dangerous intensity of X-rays may be emitted by tubes operating at voltages higher than approximately 5 kV. Adequate protection (X-ray shielding) for the operator is then necessary. The emission intensity of X-rays may correspond to a value of voltage much higher than that expected from the actual value applied to the tube.

Poor focusing may result in excessive X-radiation.

This tube is equipped with a lead shielding which under normal conditions reduces the radiation values below 0,5 mR/h, measured at a distance of 1 m from the tube axis.

REFLEX KLYSTRONS

C







## RUGGEDIZED TUNABLE REFLEX KLYSTRON

Mechanically tunable lightweight rugged reflex klystron with integral cavity, waveguide output and flying leads, suitable for operation at low pressures.

### QUICK REFERENCE DATA

Frequency range, tunable within the band	f	10,5 to 12,2 GHz
Power output	$W_o$	400 mW
Construction		waveguide output

### HEATING: indirect

Heater voltage	$V_f$		6,3 V $\pm$ 10%
Heater current at $V_f = 6,3$ V	$I_f$		1,2 A
Cathode heating time	$t_w$	min.	15 s

### LIMITING VALUES (Absolute limits)

Resonator voltage	max.	450 V
Resonator current	max.	70 mA
Negative reflector voltage		20 to 1000 V
Body temperature	max.	200 °C

For maximum life the body temperature should be kept below 100 °C.

### COOLING: natural or forced air

Forced-air cooling is necessary for a resonator input greater than 10 W.

### CONNECTIONS

Yellow:	heater		
White:	heater + cathode		
Green:	i.c. (cathode)	Net mass:	200 g
Grey:	reflector	Mounting position:	any
Maroon:	cavity	Mechanical tuning with bolt and nut	

### TUNING

Loosen both tuning nuts at socket side. Turn both nuts in centre in small steps to the left or to the right until required frequency is obtained. Then fix lower nuts again. Do not touch lock nut at reflector side.

MECHANICAL DATA

Dimensions in mm

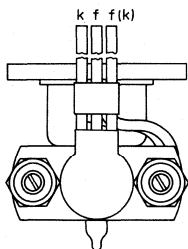

**WARNING**

*Do not apply the heater voltage to the green connector as this will result in the destruction of the tube.*

Output waveguide

RG-52/U (WR90)

Plane flange

UG-39/U

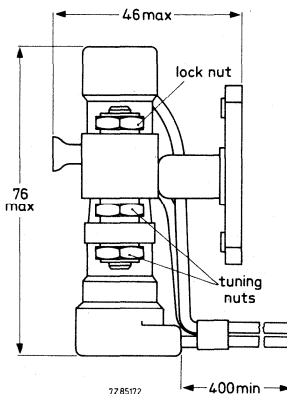
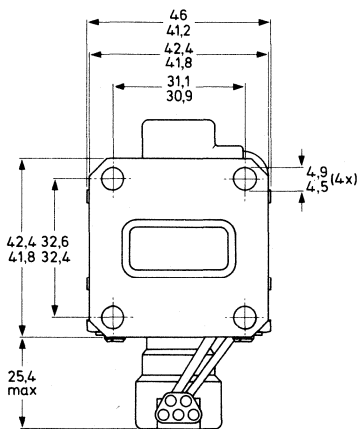

**TYPICAL CHARACTERISTICS**

Mechanical tuning range	10,5 to 12,2 GHz
Electronic tuning range between half-power points at any point in the mechanical tuning range at $V_{res} = 400 V$	> 30 MHz
Reflector modulation sensitivity at $f = 10,5$ to $12,2$ GHz	0,8 to 2,0 MHz/V
Power output at any frequency in the mechanical tuning range with reflector voltage optimized at $V_{res} = 400 V$	> 50 mW
Reflector voltage range for maximum power output over the mechanical tuning range	-120 to -370 V
Reflector voltage for maximum power output at centre frequency in principal mode at $V_{res} = 400 V$	-260 V



Frequency drift after first 5 minutes of operation			0,5 MHz
Temperature coefficient in the range $T_{amb} = -10$ to $+40$ °C		<	0,25 MHz/K
Frequency change with atmospheric pressure change equivalent to operation at			
0 to 20 km altitude	1	<	3 MHz
0 to 30 km altitude	2	<	10 MHz
Frequency modulation under vibration of 5 g applied to the flange (50 to 5000 Hz in three planes)		<	4 MHz

**OPERATING CHARACTERISTICS**

Frequency	10,5	11,5	12,2 GHz
Resonator voltage	400	400	400 V
Resonator current	65	65	65 mA
Reflector voltage	-190	-260	-315 V
Output power, matched load	150	270	370 mW
optimized load	320	400	420 mW
Electronic tuning range between half-power points	58	52	47 MHz
Reflector modulation coefficient	1,0	1,0	1,0 MHz/V

Frequency	10,5	11,5	12,2 GHz
Resonator voltage	200	200	200 V
Resonator current	23	23	23 mA
Reflector voltage	-60	-90	-110 V
Output power, matched load	10	22	27 mW
optimized load	25	30	27 mW
Electronic tuning range between half-power points	60	50	38 MHz



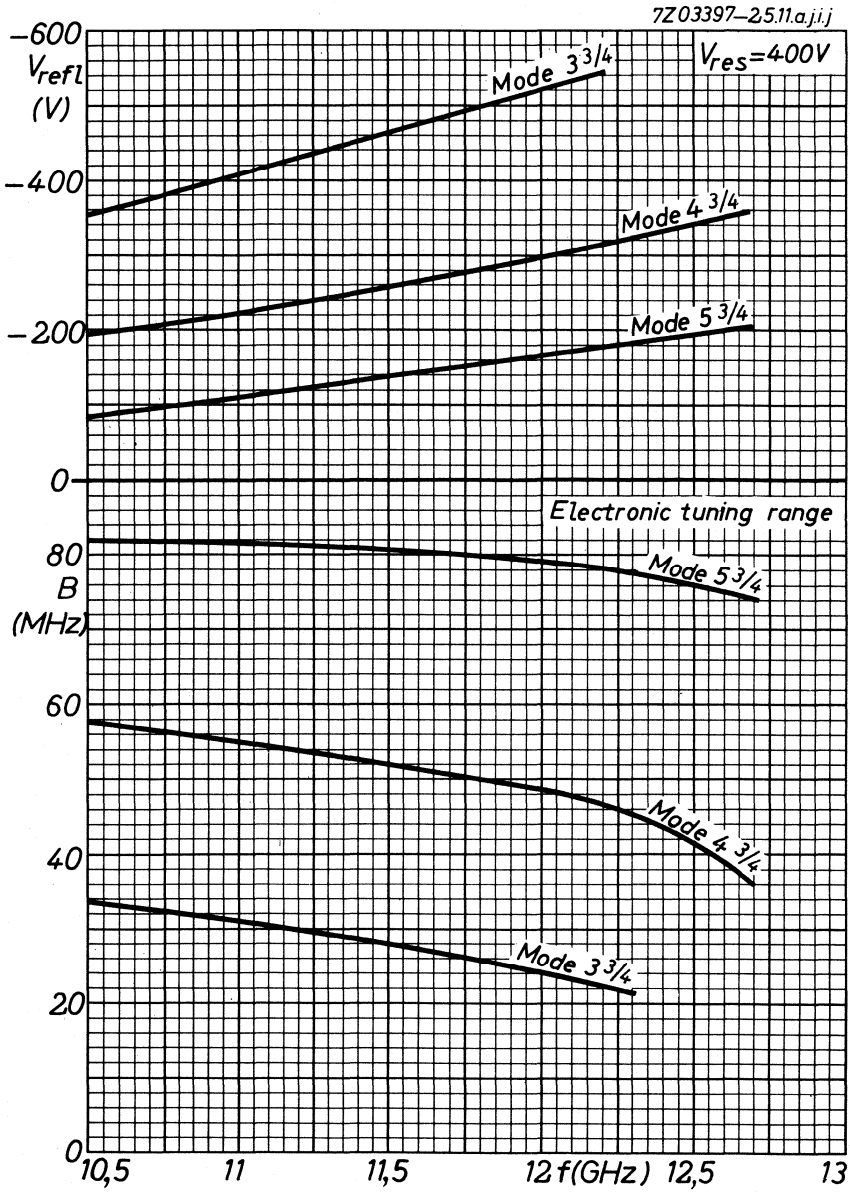

Fig. 2.

7203396-25.11a.jij

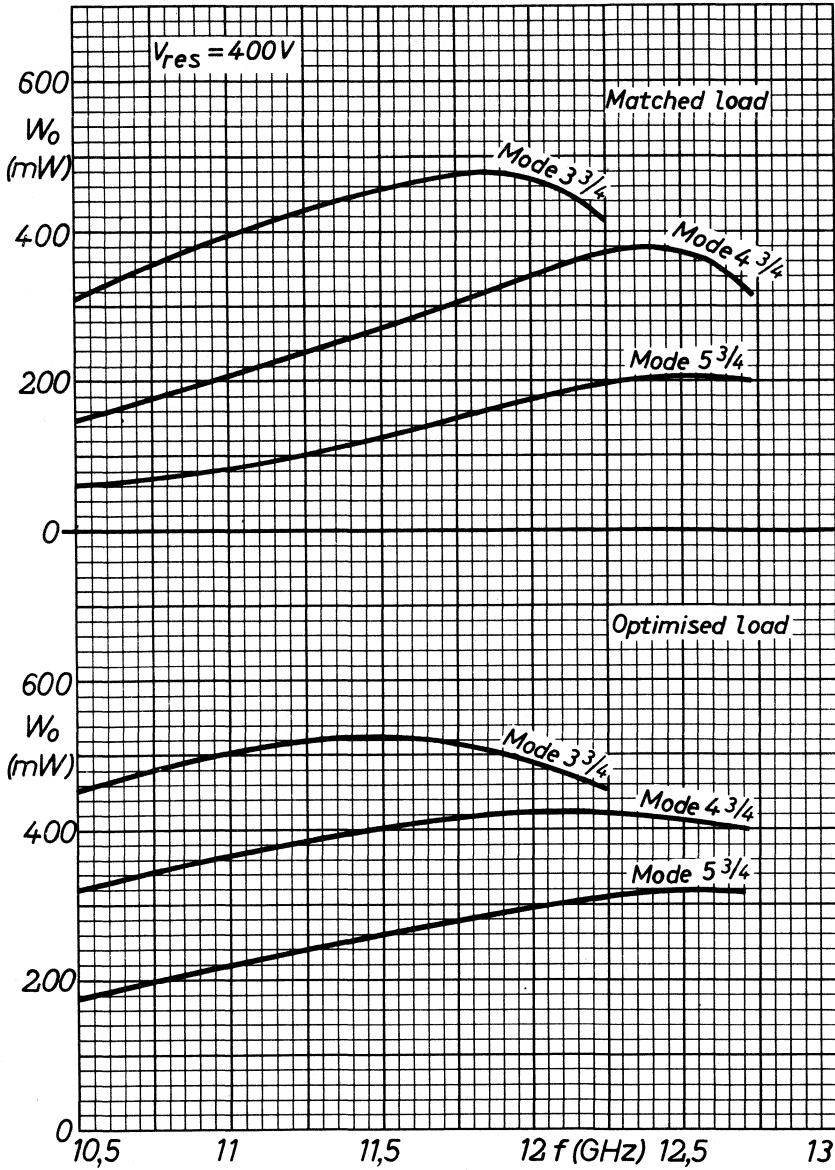

Fig. 3.

7Z03398-25.11.a.jjj

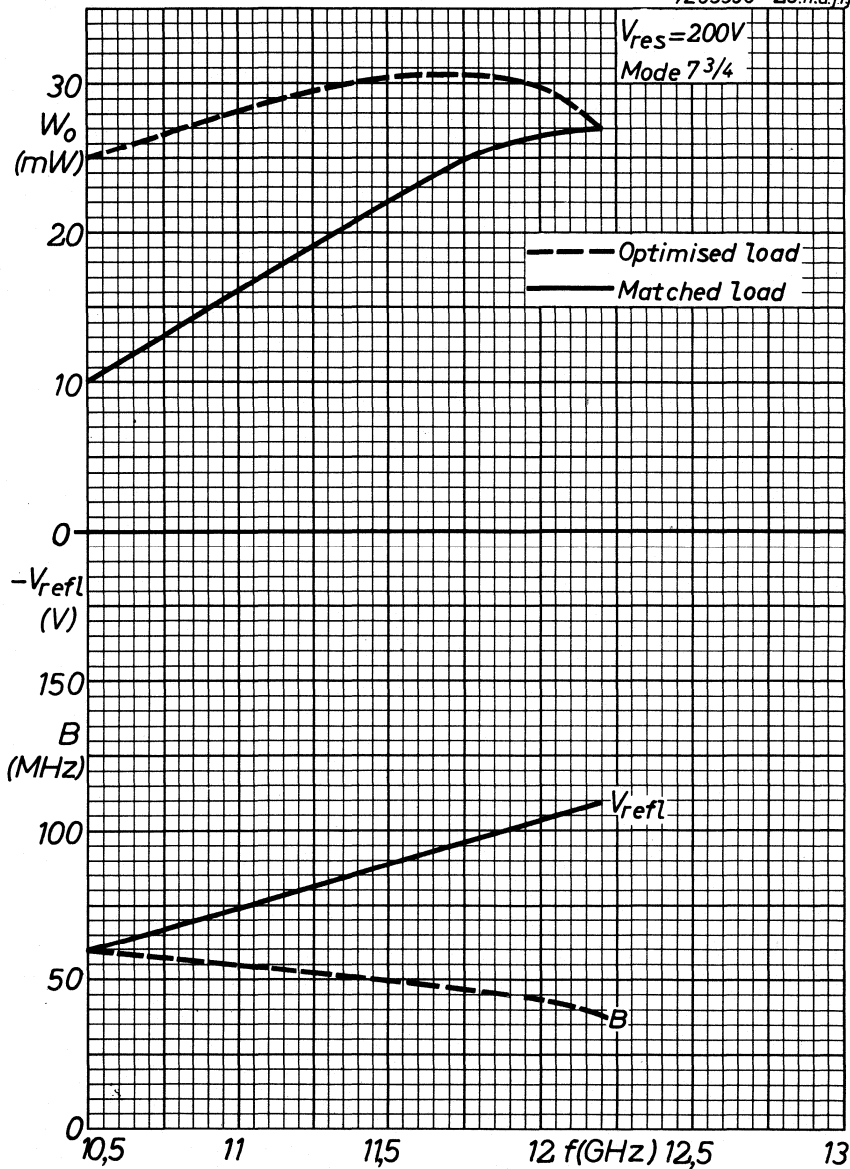

Fig. 4.



## TUNABLE REFLEX KLYSTRON

Mechanically tunable lightweight reflex klystron with integral cavity and waveguide output.

### QUICK REFERENCE DATA

Frequency range, tunable within the band	f	10,5 to 12,2 GHz
Power output	$W_o$	400 mW
Construction		waveguide output

### HEATING: indirect

Heater voltage	$V_f$	6,3 V $\pm$ 10%
Heater current at $V_f = 6,3$ V	$I_f$	1,2 A
Cathode heating time	$t_w$	min. 15 s

### LIMITING VALUES (Absolute limits)

Resonator voltage	max.	450 V
Resonator current	max.	70 mA
Negative reflector voltage		20 to 1000 V
Body temperature	max.	200 °C

For maximum life the body temperature should be kept below 100 °C.

### COOLING: natural or forced air

Forced-air cooling is necessary for a resonator input greater than 10 W.

### TUNING

Loosen both tuning nuts at socket side. Turn both nuts in centre in small steps to the left or to the right until required frequency is obtained. Then fix lower nuts again. Do not touch lock nut at reflector side.

### WARNING

Do not apply the heater voltage to the cathode pin as this will result in the destruction of the tube.

Output waveguide	RG-52/U (WR90)
Plain flange	UG-39/U
Net mass: 200 g	Mounting position: any
Base: Pee Wee 3 pin (A3-1)	
Socket: E2 555 37	Mechanical tuning with bolt and nut
Connector for reflector: 55316	

MECHANICAL DATA

Dimensions in mm

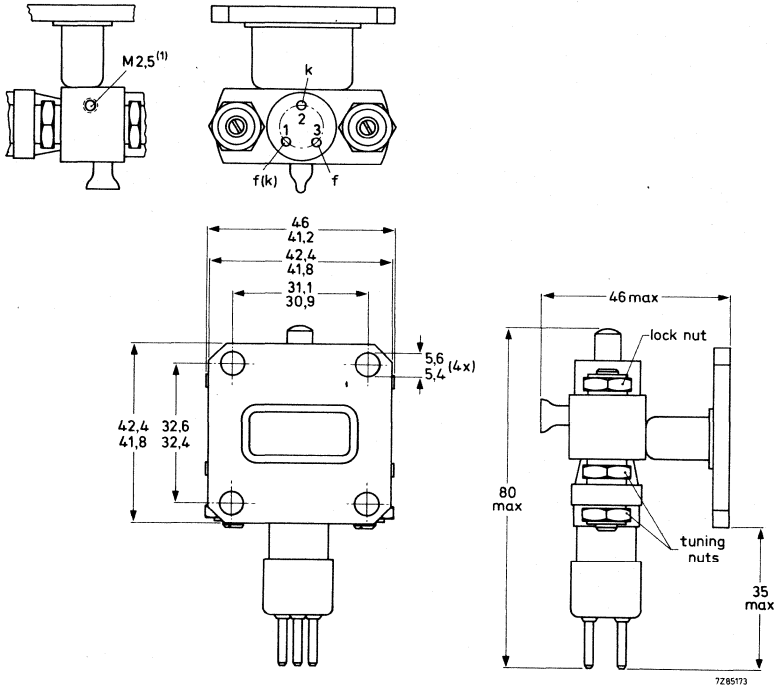

TYPICAL CHARACTERISTICS

Mechanical tuning range	10,5 to 12,2 GHz
Electronic tuning range between half-power points at any point in the mechanical tuning range at $V_{res} = 400$ V	> 30 MHz
Reflector modulation sensitivity at $f = 10,5$ to 12,2 GHz	0,8 to 2,0 MHz per V
Power output at any frequency in the mechanical tuning range with reflector voltage optimized at $V_{res} = 400$ V	> 50 mW
Reflector voltage range for maximum power output over the mechanical tuning range	-100 to -400 V
Reflector voltage for maximum power output at centre frequency in principal mode at $V_{res} = 400$ V	-260 V

Frequency drift after first 5 minutes of operation	0,5 MHz
Temperature coefficient in the range $T_{amb} = -10$ to $+40$ °C	< 0,25 MHz/K

**OPERATING CHARACTERISTICS**

Frequency	10,5	11,5	12,2 GHz
Resonator voltage	400	400	400 V
Resonator current	65	65	65 mA
Reflector voltage	-190	-260	-315 V
Output power, matched load	150	270	370 mW
optimized load	320	400	420 mW
Electronic tuning range between half-power points	58	52	47 MHz
Reflector modulation coefficient	1,0	1,0	1,0 MHz/V

Frequency	10,5	11,5	12,2 GHz
Resonator voltage	200	200	200 V
Resonator current	23	23	23 mA
Reflector voltage	-60	-90	-110 V
Output power, matched load	10	22	27 mW
optimized load	25	30	27 mW
Electronic tuning range between half-power points	60	50	38 MHz



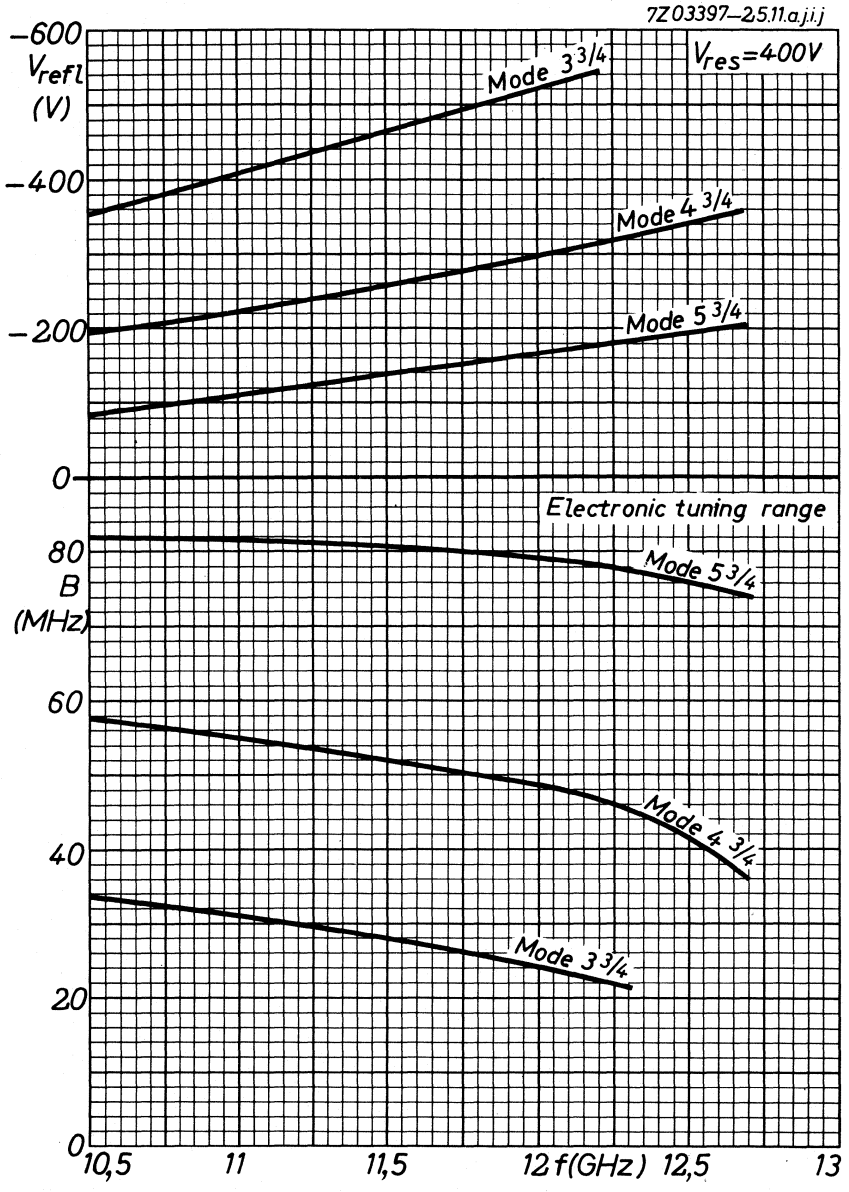

Fig. 2.



7Z03396-25.11ajij

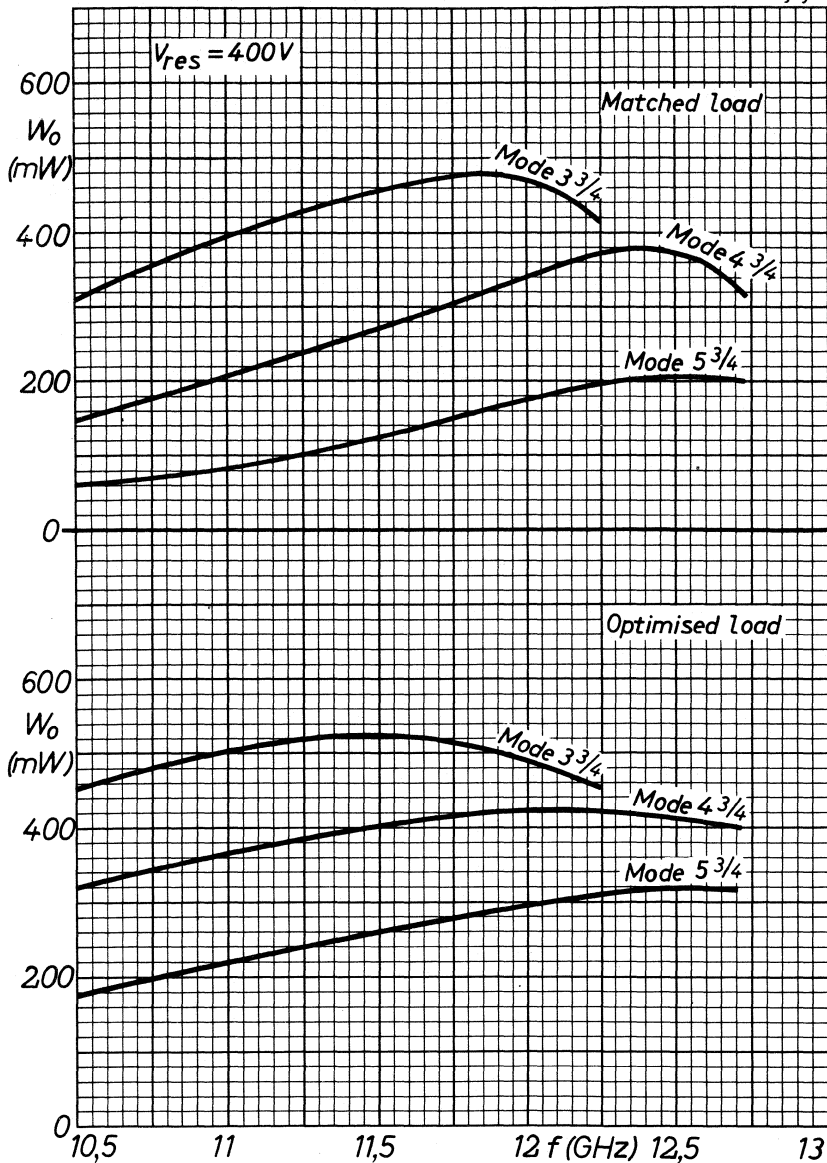

Fig. 3.

7Z03398-25.11.ajj

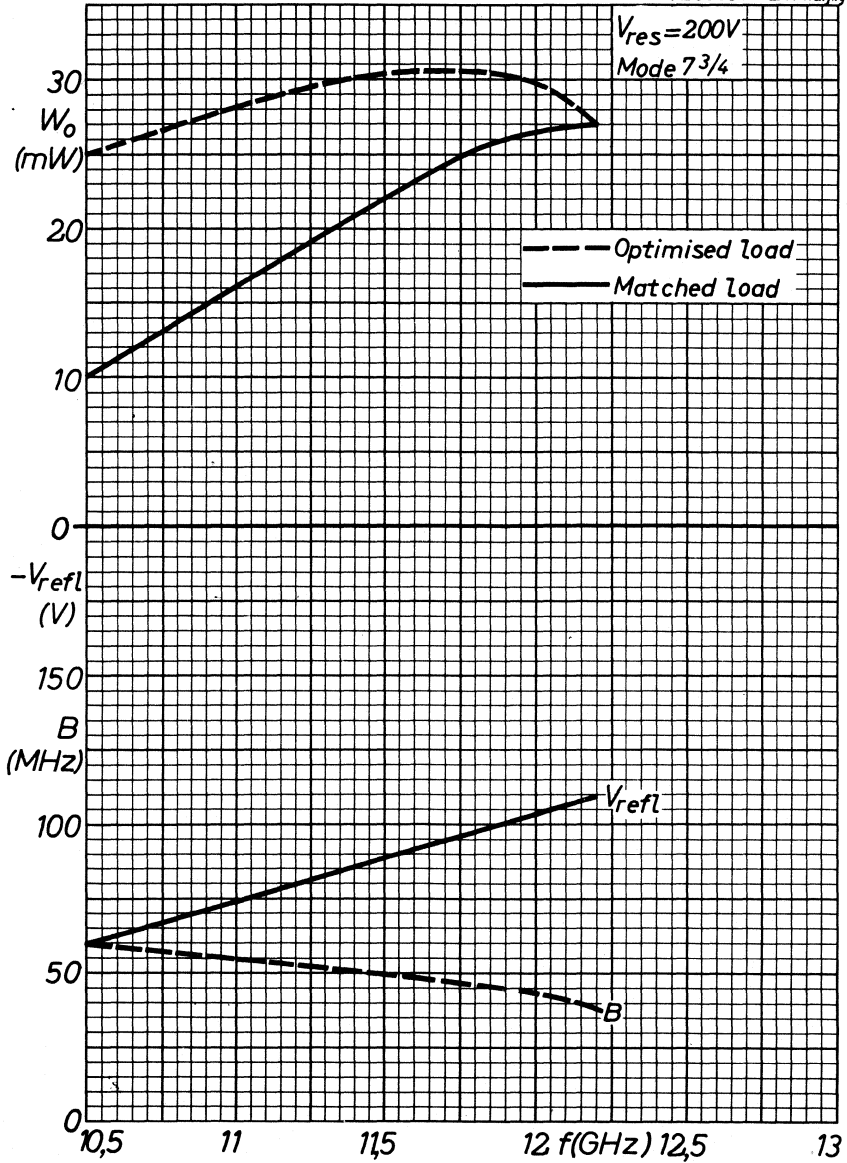

Fig. 4.

TRAVELLING-WAVE TUBES

D





## TRAVELLING-WAVE TUBE

6 GHz travelling-wave tube with a periodic permanent magnet mount intended for use in the power output stages of wideband microwave links.

### QUICK REFERENCE DATA

Frequency range	f	5,925 to 6,425 GHz
Saturation output power	$W_{0\text{sat}}$	25 W
Gain	G	38 dB
Construction, tube mount		unpackaged periodic permanent magnet

**CATHODE:** dispenser type

**HEATING:** indirect by a.c. or d.c.

Heater voltage	$V_f$	6,3 V $\pm$ 2%
Heater current	$I_f$	0,85 to 1,05 A
Waiting time for a new tube	$t_w$ min.	2 min
	$t_w$ min.	5 min

When operated on d.c. the heater must be negative with respect to cathode.

### TEMPERATURE LIMITS AND COOLING

Absolute max. temperature at reference point on mount cooler	T	max.	140 °C
<b>Ambient temperature range</b>		min.	max.
Operation to full specification	$T_{\text{amb}}$	-10	+65 °C (note 1)
Operation without damage to tube	$T_{\text{amb}}$	-20	+65 °C
Storage	$T_{\text{amb}}$	-60	+85 °C (note 2)

### Cooling

Tube installed in convection-cooled mount type P6L11  
 horizontally mounted  
 vertically mounted

natural  
 natural assisted by convection duct  
 or low velocity air flow

A condition-cooled mount is available.

MECHANICAL DATA

Dimensions in mm

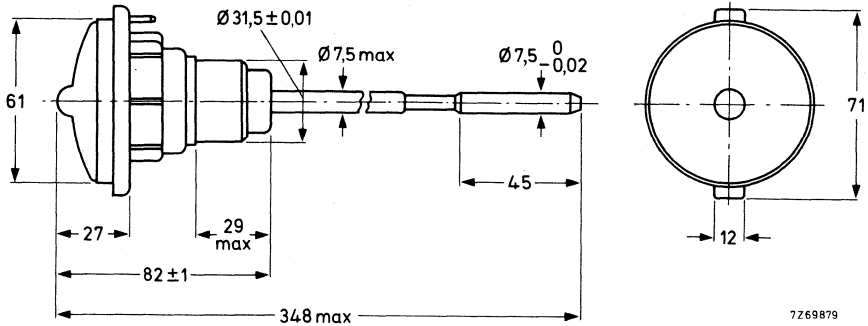

7269879

Fig. 1.

**Mounting position:** Any (but see "Cooling").

The barrel of the mount must be protected from strong magnetic fields such as from isolators, and should be several centimetres from steel plates.

Note that the tube is fragile. It should be inserted carefully into the mount and then pushed home axially. Rotation is also necessary to negotiate the withdrawal check lugs.

**Mass**

Net mass of tube: 0,15 kg

Net mass of mount: 4,9 kg

**Accessories**

Mount, convection-cooled, with 153 IEC-R70 waveguide input and output (34,85 mm x 15,799 mm) type P6L11, see Fig. 3.

**Plug connections to mount**

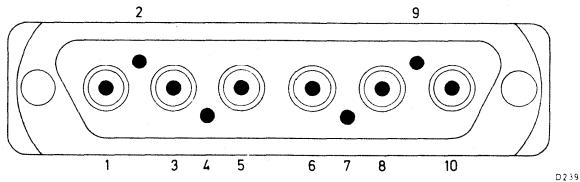

D239C

Fig. 2 Amphenol plug 17-801.

- |                                  |                  |
|----------------------------------|------------------|
| 1 helix                          | 6 cathode        |
| 2 collector (earth)              | 7 safety circuit |
| 3 grid 2 (accelerator electrode) | 8 heater         |
| 4 -                              | 9 safety circuit |
| 5 grid 1 (focusing electrode)    | 10 heater        |



**DESIGN RANGES FOR POWER SUPPLY**

Voltages are specified with respect to cathode.

Normal operation.

		min.	max.	notes
Grid 1 voltage	$V_{g1}$	-20	0 V	3
Grid 1 current	$I_{g1}$		100 $\mu$ A	
Grid 2 voltage	$V_{g2}$	1,9	2,7 kV	4,5
Grid 2 current	$I_{g2}$	-250	+250 $\mu$ A	
Helix voltage	$V_x$	3,2	3,8 kV	
Helix current	$I_x$		1,5 mA	5,6
Collector voltage	$V_{coll}$	1,9	2,1 kV	7
Collector current	$I_{coll}$		50 mA	

**TYPICAL OPERATION**

As a power amplifier with the collector earthed and tube focused in a mount type P6L11. Tubes are fully interchangeable in mounts and tube replacement is a simple operation.

Voltages are specified with respect to cathode.

**Conditions**

Frequency	f	6 GHz
Heater voltage	$V_f$	6,3 V
Grid 1 voltage	$V_{g1}$	-15 V
Helix voltage	$V_x$	3,4 kV
Collector voltage (earth)	$V_{coll}$	2 kV
Collector current	$I_{coll}$	45 mA

**Performance**

Gain	G	38 dB
Output power	$W_o$	15 W
Noise factor (including gas noise)	F	28 dB
Hot input match	VSWR	1,2
Hot output match	VSWR	1,4
Grid 1 current	$I_{g1}$	1 $\mu$ A
Grid 2 current	$I_{g2}$	5 $\mu$ A
Helix current	$I_x$	0,5 mA
Grid 2 voltage	$V_{g2}$	2,2 kV



**LIMITING VALUES** (Absolute maximum rating system)

notes

Voltages are specified with respect to cathode.

Grid 1 voltage	$-V_{g1}$	max.	250 V
		min.	0 V
Grid 2 voltage	$V_{g2}$	max.	3 kV
Helix voltage	$V_x$	max.	4 kV
Helix current	$I_x$	max.	1,3 mA 6
Collector voltage	$V_{coll}$	max.	2,2 kV
		min.	1,9 kV
Collector current	$I_{coll}$	max.	50 mA
Collector dissipation	$W_{coll}$	max.	100 W
R.F. input power	$W_i$	max.	250 mW 8

**TEST CONDITIONS AND LIMITS**

Tube focused in mount P6L11.

**Conditions**

Heater voltage	$V_f$	6,3 V
Grid 1 voltage	$V_{g1}$	-15 V
Grid 2 voltage	$V_{g2}$	6,9
Helix voltage	$V_x$	10
Collector voltage	$V_{coll}$	1,9 kV
Collector current range	$I_{coll}$	40 to 50 mA 16
Output power	$W_o$	15 W
Frequency range	$f$	5,925 to 6,425 GHz 11

**Limits and characteristics**

		min.	max.
Gain at $W_o = 15$ W	G	37	40 dB
Noise factor at $W_o = 15$ W, design test only	F		30 dB
Saturation output power	$W_{o\ sat}$	23	W 12
Hot input match	VSWR		1,5 13
Hot output match	VSWR		2 13
Grid 2 voltage	$V_{g2}$	1,9	2,7 kV
Helix voltage	$V_x$	3,2	3,8 kV
Grid 1 current	$I_{g1}$		100 $\mu$ A
Grid 2 current	$I_{g2}$		250 $\mu$ A
Helix current	$I_x$		1,3 mA 6
A.M./P.M. conversion at $W_o = 15$ W (design test only)			2 $\%$ /dB 14
Attenuation			15

## NOTES

1. The magnetic circuit is fully temperature-compensated in this range, and the operation of the tube will not change as the temperature is varied.
2. If the temperature of the mount is lowered below  $-60^{\circ}\text{C}$  the magnets will suffer an irreversible change.
3.  $V_{g1}$  is normally fixed at  $-15\text{ V}$ .
4. For adjustment of focus it is also necessary for the grid 2 voltage to be variable in the range 0 to 1,9 kV without stabilization. As an alternative the negative voltage on grid 1 may be increased within certain limits to reduce the collector current (see "Limiting Values").
5. The power supply should be designed so that any automatic switching allows the correct cathode preheating time (which may be reduced or eliminated for momentary breaks of 5 s), followed by establishment of all electrode voltages except  $V_{g2}$ . The  $V_{g2}$  may then be applied. All supplies should usually be stabilized to within  $\pm 2\%$  except where otherwise stated. A protective device to reduce  $V_{g2}$  should operate if the helix current exceeds its limiting value (but see note 6).
6. During the focusing operation the helix current may (transiently) be allowed to reach 2 mA. It may be useful so set the focusing screws on a new mount 1,5 turns back from fully home before commencing the switch-on operation.
7. The collector voltage is usually fixed at 2 kV. This supply need not be stabilized provided that it remains in the range 1,9 to 2,1 kV when the tube is operating.
8. The output power reflected back into the tube by the load (for example the output isolator) should also not exceed this limit.
9.  $V_{g2}$  should be adjusted to give the specified collector current while cyclically adjusting focusing screws for minimum helix current.
10.  $V_x$  should be adjusted to give the maximum gain at the specified output power. Focusing should then be re-optimized.
11. The tube is tested at the centre and the extremes of the frequency range.
12. Measured pulsed at a duty ratio of 1:2. If necessary the helix voltage is readjusted to give maximum output power as the input power is increased and the focus re-optimized.
13. This is obtained without adjustment at each frequency ("plug-in" match).
14. The value given for A.M. to P.M. conversion is that obtained under the stated conditions. Improved values may be obtained with other settings of helix voltage and input power.
15. With electrode voltages not applied minimum attenuation is 60 dB.
16. Specified on data sheet enclosed with tube.

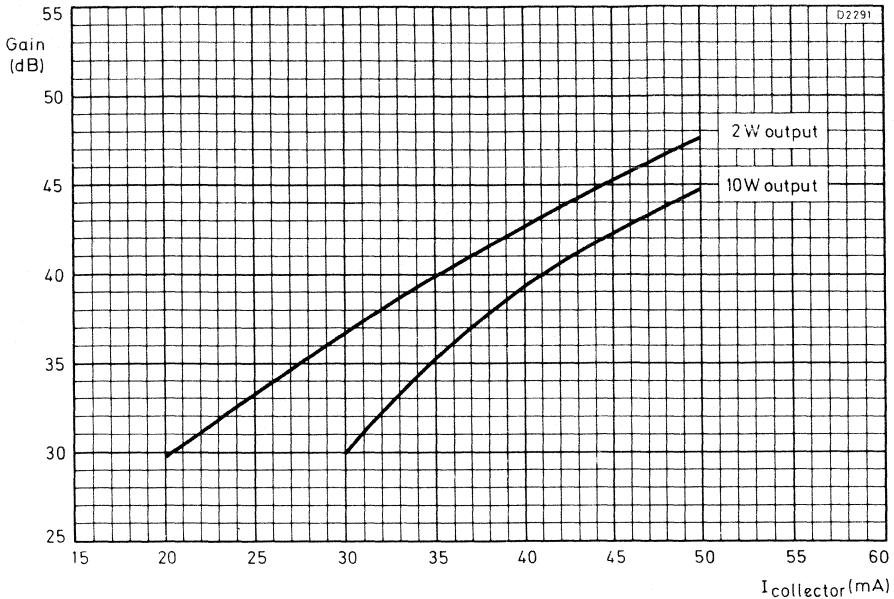

Fig. 4 Gain as a function of collector current at 6,2 GHz.

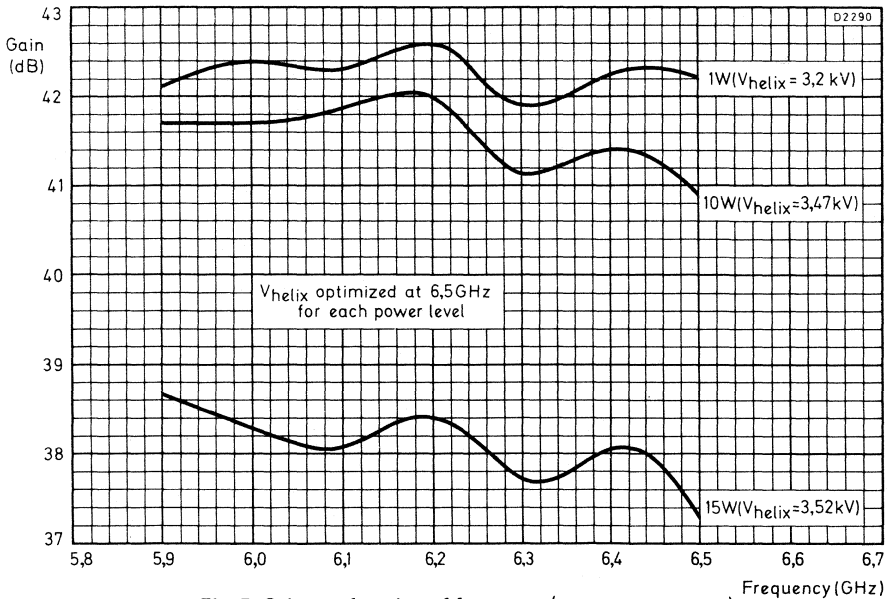

Fig. 5 Gain as a function of frequency (power as parameter).

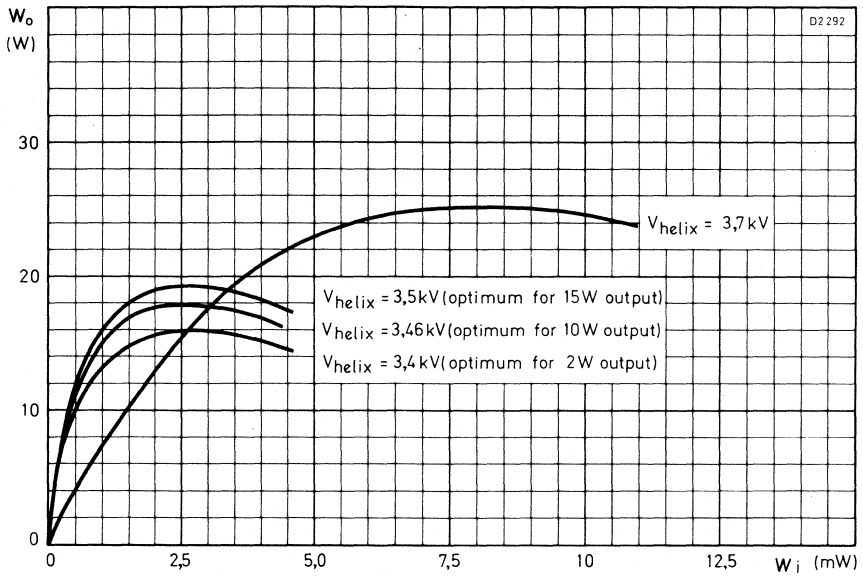

Fig. 6 Output power as function of input power (helix voltage as parameter) at 6,2 GHz.

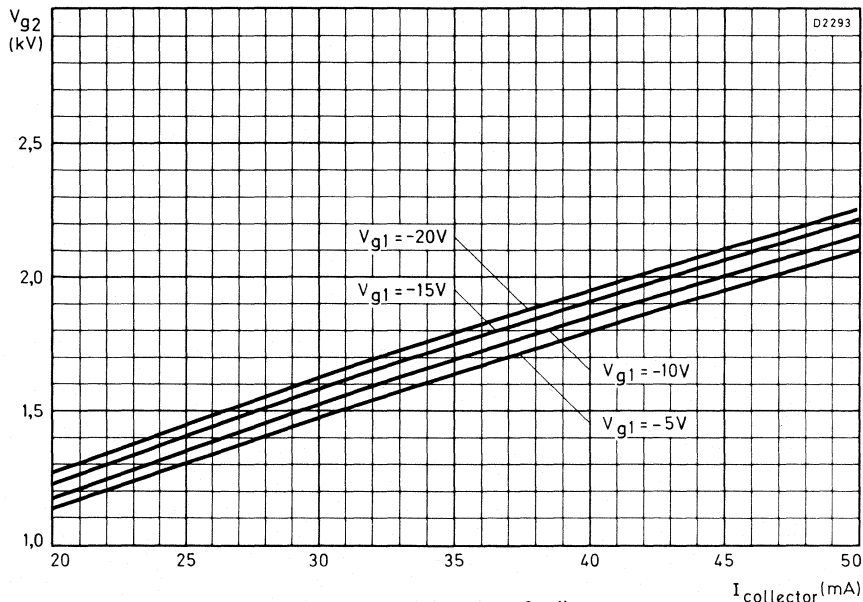

Fig. 7 Grid 2 voltage as a function of collector current.

## TRAVELLING-WAVE TUBE

4 GHz travelling-wave tube with a periodic permanent magnet mount designed for wide-band microwave link applications.

### QUICK REFERENCE DATA

Frequency range	3,4 to 4,2 GHz
Saturation output power at midband	25 W
Low-level gain	42 dB
Interchangeability	plug-in focus, plug-in match
Construction	unpackaged
tube	glass-metal envelope, metal-ceramic base
mount	periodic permanent magnet

**CATHODE:** dispenser type

**HEATING:** indirect by a.c. or d.c.

When operated on d.c. the cathode must be connected to the positive side of the heater power supply.

Heater voltage  $V_f$  6,3 V  $\pm$  2%

Heater current at  $V_f = 6,3$  V  $I_f$  approx. 1 A

Waiting time  $t_w$  min. 2 min

For shorter waiting time when the tube already has been in operation see "Application of voltages".

**COOLING:** Natural cooling

by convection with mount 55329 or

by conduction with mount 55332

### MECHANICAL DATA

Dimensions in mm

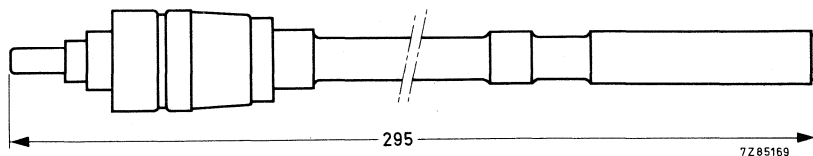

Fig. 1.

**Mounting position:** Any. See "Design and operating notes"

### Mass

of tube

approx. 60 g

of mount

approx. 4,5 kg

**ACCESSORIES** (to be ordered separately)

PPM mount for convection cooling

type 55329

PPM mount for conduction cooling

type 55332

Waveguide taper (two required) to waveguide IEC-R40 (58,17 x 29,08 mm<sup>2</sup>)  
with flange IEC-UER40

type 55330

Waveguide taper (two required) to waveguide IEC-F40 (58,17 x 7 mm<sup>2</sup>)  
with flange IEC-UGF40

type 55333

Clamp for fastening of mount (two required)

type 55331

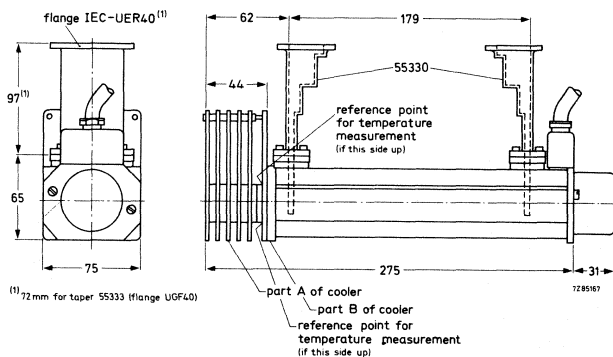

Fig. 2 Mount 55329 with convection cooling and waveguide tapers 55330.

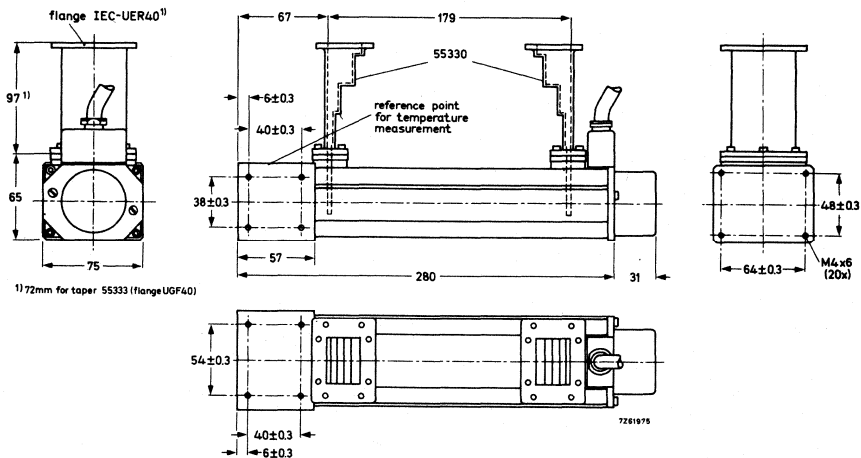

Fig. 3 Mount 55332 with conduction (heatsink) cooling and waveguide tapers 55330.

**Connections**

The mount is provided with flying leads, marked with colours

Heater, cathode	yellow
Heater	brown
Focusing electrode	green
Accelerator	blue
Helix	to be earthed via mount
Collector	red
Safety circuit (closed or opened, when putting on or taking off the mount cap)	two violet leads

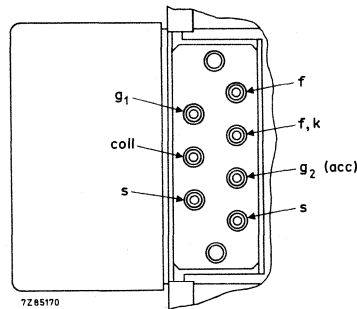

Fig. 4 Connections in cable housing.

**GENERAL CHARACTERISTICS**

Frequency range	f	3,4 to 4,2 GHz
Saturation output power (CW)	$W_{sat}$	25 W (note 1)
Low-level gain	G	42 dB (note 2)
Gain at $W_o = 15$ W	G	38 dB (note 3)
Thermal noise factor at $W_o = 15$ W	F	24 dB (note 4)
AM to PM conversion at $W_o = 15$ W		3 °/dB (note 4)
Cold match at input and output (f = 3,4 to 4,2 GHz)	VSWR	max. 1,5 (note 5)

**Notes**

1. Typical value measured at f = 3,8 GHz,  $I_{coll} = 60$  mA.  $W_i$  and  $V_x$  optimally adjusted for saturation output power.
2. Typical value measured at f = 3,8 GHz,  $I_{coll} = 60$  mA.  $W_o < 1$  W.  $V_x$  optimally adjusted for low-level gain.
3. Typical value measured at f = 3,8 GHz,  $I_{coll} = 60$  mA.  $V_x$  adjusted for optimum gain.
4. Typical value measured at f = 4 GHz,  $I_{coll} = 60$  mA.  $V_x$  adjusted for optimum gain.
5. Measured on the cold tube, i.e. with the beam switched off and without use of any matching device (plug-in match).

**TYPICAL OPERATION**

Voltages are specified with respect to the cathode

Frequency	f		3,6	GHz	
Output power	$W_o$		15	10	5 W
Helix voltage (adjusted for optimum gain)	$V_x$	approx.	2250	2200	2150 V
Collector voltage	$V_{coll}$		1500	1300	1100 V
Focusing electrode voltage	$V_{g1}$		-5	-5	-5 V
Collector current	$I_{coll}$		60	60	60 mA
Gain	G		38	40	41 dB
Accelerator voltage*	$V_{g2}$	approx.	1550	1550	1550 V
Accelerator current	$I_{g2}$		< 0,1	< 0,1	< 0,1 mA
Helix current (plug-in focus)	$I_x$		0,3	0,3	0,2 mA
Thermal noise factor	F		24	21,5	20,5 dB
AM to PM conversion			3	2,5	1,5 °/dB

Frequency	f		4,0	GHz	
Output power	$W_o$		15	10	5 W
Helix voltage (adjusted for optimum gain)	$V_x$	approx.	2150	2100	2050 V
Collector voltage	$V_{coll}$		1500	1300	1100 V
Focusing electrode voltage	$V_{g1}$		-5	-5	-5 V
Collector current	$I_{coll}$		60	60	60 mA
Gain	G		38	40	41 dB
Accelerator voltage*	$V_{g2}$	approx.	1550	1550	1550 V
Accelerator current	$I_{g2}$		< 0,1	< 0,1	< 0,1 mA
Helix current (plug-in focus)	$I_x$		0,3	0,3	0,2 mA
Thermal noise factor	F		24	21,5	20,5 dB
AM to PM conversion			3	2,5	1,5 °/dB

\* To be adjusted for indicated collector current.



**LIMITING VALUES** (Absolute maximum rating system)

Voltages are with respect to the cathode unless otherwise specified.

Focusing electrode voltage	$-V_{g1}$	min.	0 V
		max.	50 V
Accelerator voltage	$V_{g2}$	max.	2000 V
Helix voltage	$V_x$	max.	2700 V
Collector to helix voltage	$V_{coll-x}$	max.	2500 V
Cathode current	$I_k$	max.	65 mA
Accelerator current	$I_{g2}$	max.	0,3 mA
Helix current	$I_x$	max.	3 mA
R.F. input level	$W_i$	max.	200 mW
Collector dissipation at $T_{amb} = 65\text{ }^{\circ}\text{C}$	$W_{coll}$	max.	90 W
Power reflected from load (to avoid overheating of the helix)		max.	2 W
Cooler temperature at reference point			
mount type 55329	T	max.	140 $^{\circ}\text{C}$
mount type 55332	T	max.	150 $^{\circ}\text{C}$



## DESIGN AND OPERATING NOTES

### 1. General design considerations

Equipment design should be oriented around the tube specifications given in these data sheets and not around one particular tube since due to normal production variations the design parameters will vary around the nominal values given.

### 2. Installation of the mount

Two main methods may be discerned:

- a. Fixing the mount relative to the microwave circuit by only connecting the waveguide tapers to the input and output sides of the circuit.
- b. Employing (a) and establishing additional support by fastening the mount to the rack with two clamps 55331. In this case it is recommended that a short piece of flexible waveguide be used at input and output side to prevent excessive strain on the mount via the tapers, unless very careful alignment of the waveguide components can be assured.

Possible forces on the waveguides must not produce a moment greater than 20 Nm at the flanges.

#### 2.1 Mount type 55329

The cooler of the mount consists of the parts A and B (see Fig. 2). Part A is slightly movable and should be handled with special care. The mount should be installed in such a way, that it is not resting on the parts A or B of the cooler, and that part A always remains freely movable. When a tube is in the mount, no forces should be exerted on part A, since they would be directly transferred to the collector.

#### 2.2 Mount type 55332

This mount has no movable parts. If clamps are used (method b) the slightly larger dimensions of the cooler with regard to the main part of the mount must be considered.

#### 2.3 Magnetic shielding

The periodic permanent magnet mount is completely shielded. This implies that no additional measures need be taken to prevent the magnetic properties of the mount from being affected by external magnetic fields. The mount will not influence surrounding equipment which is susceptible to stray magnetic fields. Several mounts may be placed side by side without disturbance of the focusing qualities. Isolators may be installed quite near to the mount.

#### *Warning*

*If any part of the shielding is removed, the magnetic properties of the mount may be disturbed irreversibly.*

### 3. Installation of the tube

Unlock the mount cap (see outline drawing) by turning it slightly counter-clockwise. The cap can then easily be removed, and the tube inserted by carefully pushing it in. Finally put the cap on the mount again, and lock by turning it clockwise. These instructions are also a guide for taking the tube out of the mount.

#### 4. Safety

The supply voltages are fed to the tube via the mount cap. When the cap is unlocked all voltages are removed from the tube. The two violet leads can be incorporated into an additional safety circuit which switches the voltages off at the power supply if the cap is unlocked. Thus the voltages can also be removed from the mount. The mount should always be earthed.

#### 5. Power supply

The design of the power supply depends on whether 5, 10 and/or 15 W operation is desired. An example of a supply circuit for 10 and 15 W operation is given in Fig. 5.

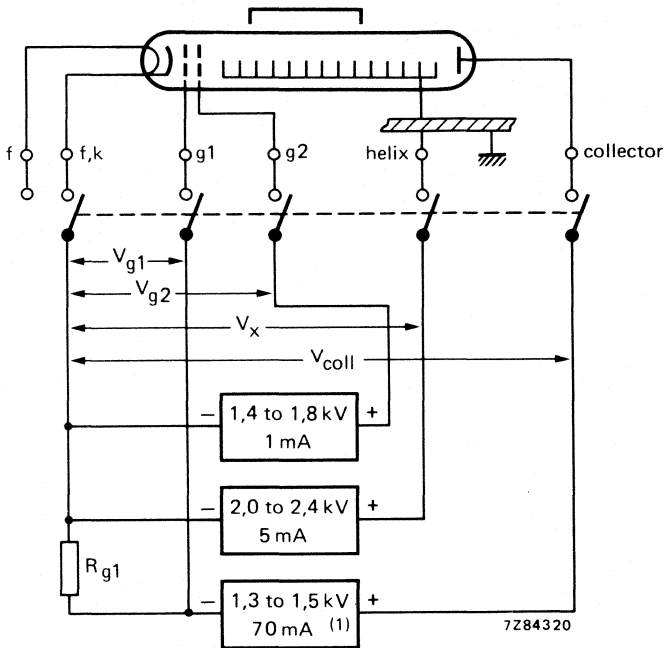

Fig. 5 For 5 W operation a minimum of 1,1 kV is required.

The design of the power supply should be so that  $V_{g2}$  can be varied between 1,4 and 1,8 kV.  $V_x$  can be varied between 2,0 and 2,4 kV.  $V_{g1}$  is  $-5$  V at  $I_{coll} = 60$  mA. The collector voltage must be 1,1 kV, 1,3 kV, or 1,5 kV at  $I_{coll} = 60$  mA for a desired output of 5 W, 10 W, or 15 W respectively.

For measurements of saturation output power the collector voltage should be 1,7 kV (between 3,8 and 4,2 GHz) and 1,85 kV (between 3,4 and 3,8 GHz). The helix voltage may then reach 2,7 kV.

## 6. Cooling

Tube and mount need no artificial means of cooling. The natural cooling of the collector has been made possible of depression of the collector potential with respect to the helix and by ensuring adequate heat transfer from the collector to the environment.

### 6.1 Mount 55329

Under typical operating conditions and at an ambient temperature of not more than 65 °C, the cooler temperature at the reference point (see Fig. 2) is well below the limit, provided the tube is mounted horizontally, and free air circulation is possible.

Under less favourable conditions a slight additional cooling by a low-velocity air flow may be required. Checking the temperature at the reference point then is strongly advised.

### 6.2 Mount 55332

Under typical operating conditions and at an ambient temperature of not more than 65 °C, the cooler temperature at the reference point (see Fig. 3) is well below the limit, provided an aluminium heatsink of 300 x 300 x 6 mm is mounted on one of the cooler surfaces. The heatsink should be fixed with its centre contacting the cooler and in a vertical position. The mount itself may have any position in the equipment.

This is only an example and other heatsink configurations may be employed. It will then be necessary to check the temperatures reached at the reference point under extreme conditions e.g. 65 °C ambient temperature.

## 7. Application of voltages

### 7.1 Switching-on procedure for new tubes

- 7.1.1 Apply the heater voltage for the specified waiting time.
- 7.1.2 Apply the rated voltages to the collector, to the helix, to the accelerator and to the focusing electrode in case of a separate supply simultaneously (see Notes).
- 7.1.3 Adjust the accelerator voltage to obtain a collector current of 60 mA.
- 7.1.4 Apply the r.f. input signal, adjust the level to obtain the required output power while simultaneously adjusting the helix voltage for optimum gain.

### 7.2 Readjustment during life

During life the collector current may decrease. A readjustment of the accelerator voltage to obtain  $I_{\text{coll}} = 60$  mA will then be necessary.

### 7.3 Switching-off procedure

All voltages may be switched off simultaneously (see Notes).

**7.4 Switching-on procedure after interruption of voltage**

- 7.4.1 Interruption of less than 40 s: All voltages may be switched on simultaneously.
- 7.4.2 Interruption of more than 40 s but less than 1 week: Apply the heater voltage for min. 40 s, then apply all other voltages simultaneously.
- 7.4.3 Interruption of more than 1 week: Apply the heater voltage for the specified waiting time of 2 min. Apply all other voltages simultaneously.

**Notes**

If the voltages cannot be switched simultaneously the possibility exists that all the cathode current is flowing to the accelerator or the helix. This condition may never last for more than 10 ms, otherwise it will cause permanent damage to the tube. This may be avoided by switching the accelerator voltage on after the other electrode voltages, or off before the other electrode voltages.

**8. Input and output circuit and group delay**

In order to avoid phase distortions due to long-line effect, the insertion of an isolator between tube and antenna, and between tube and pre-stage is strongly recommended. The isolators should be positioned as close to the tube as possible.

If isolators with a VSWR of less than 1,05 are used at a short distance from the tube, the reflections result in a variation of group delay of less than 0,2 nanoseconds over a band of 20 MHz.

It may be noted that the difference between the voltage reflection coefficients of the hot and cold (i.e. without beam) tube is less than 0,2 for the input as well as the output side.

**9. Environmental conditions**

Ambient temperature

storage

$T_{amb}$

min. -60 °C

max. +65 °C

operation

$T_{amb}$

min. -30 °C

max. +65 °C

Relative humidity

0 to 95 %

The tube and mount resist fungus attack.

For changes in gain and helix current over the specified temperature range see Fig. 19.



7Z06572

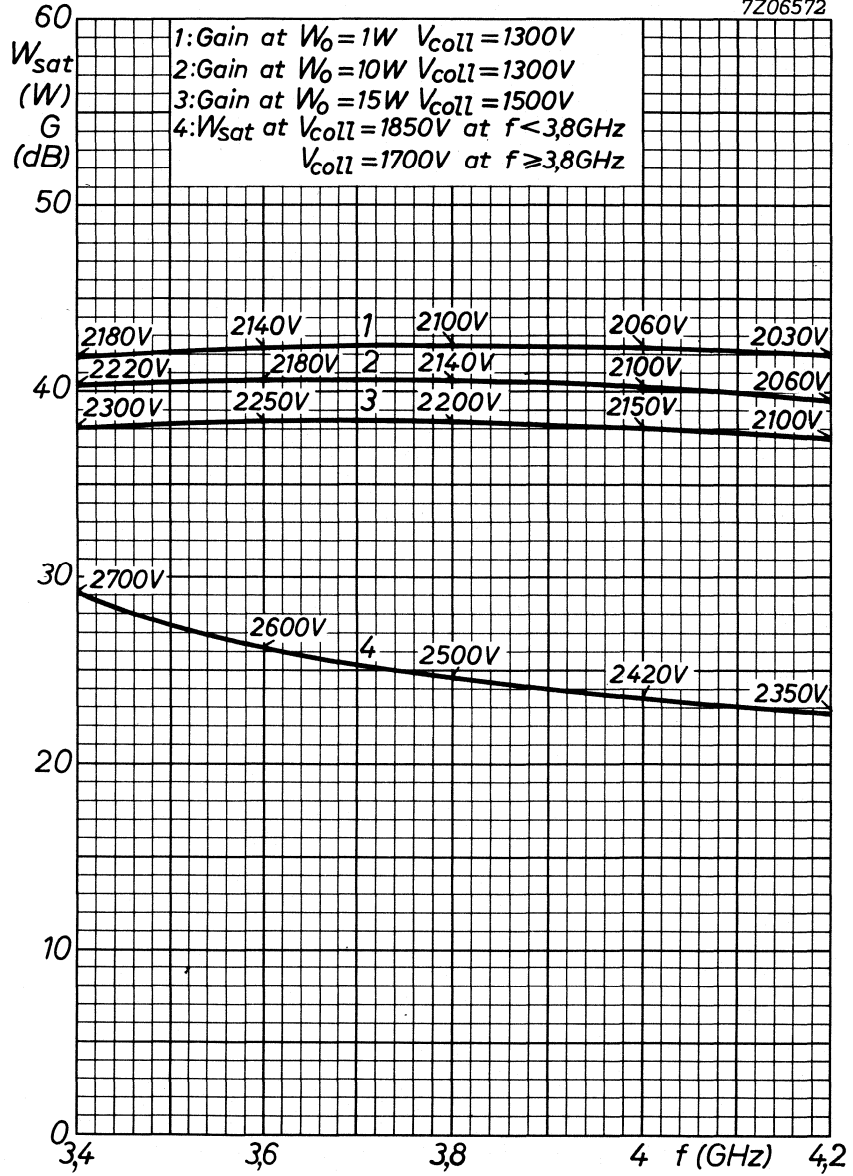

Fig. 6 Ratio of gain and saturation power to frequency.

7Z06573

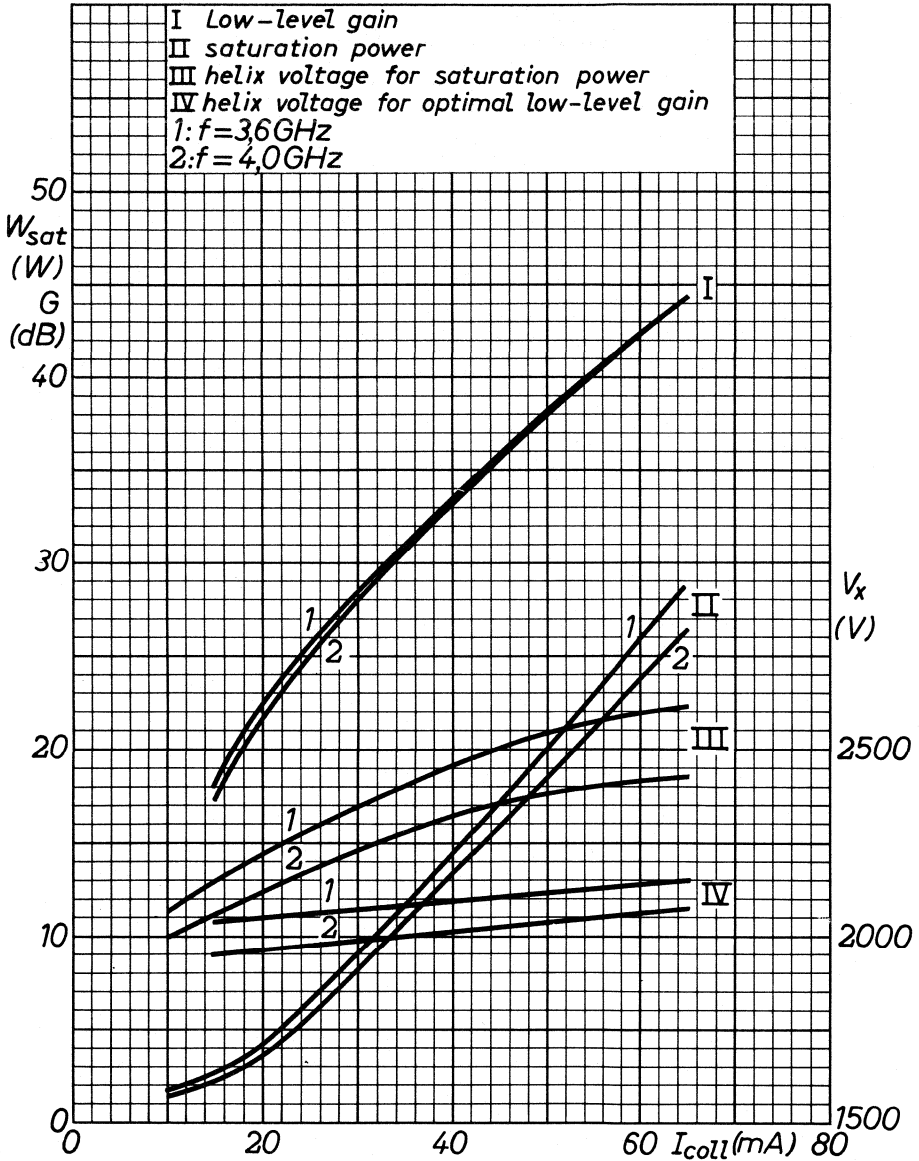

Fig. 7 Ratio of gain and saturation power to collector current.

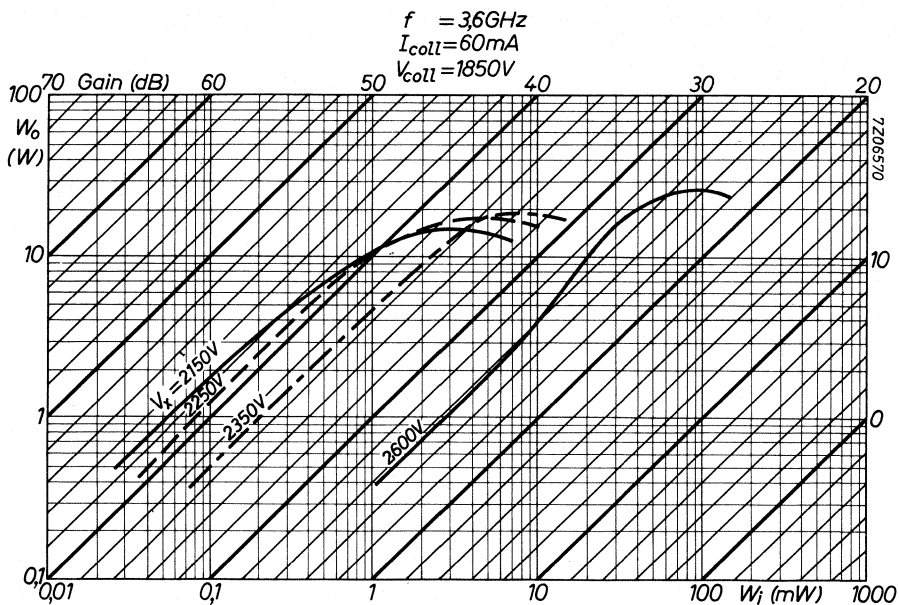

Fig. 8 Ratio of output power to input power.  $f = 3,6\text{ GHz}$ ;  $I_{\text{coll}} = 60\text{ mA}$ ;  $V_{\text{coll}} = 1850\text{ V}$ .

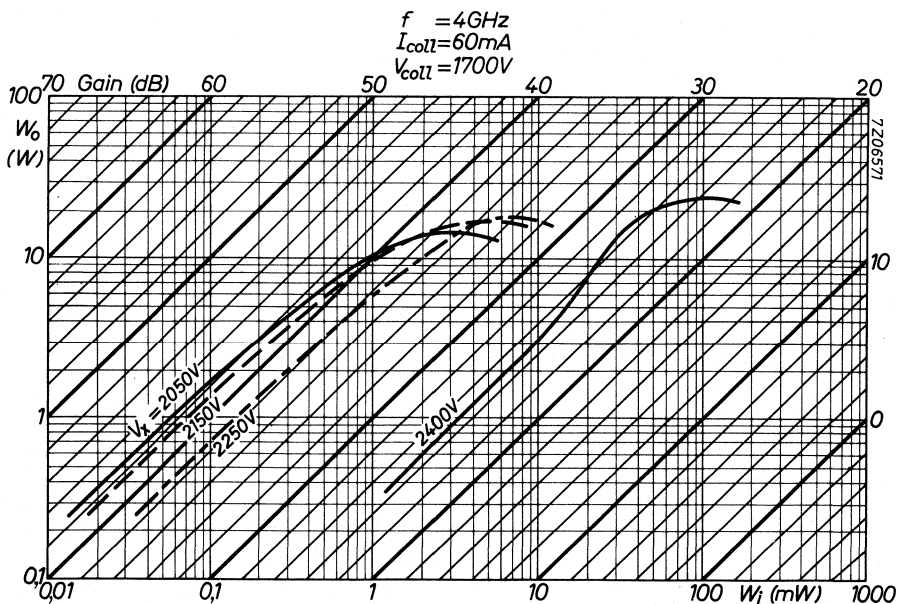

Fig. 9 Ratio of output power to input power.  $f = 4\text{ GHz}$ ;  $I_{\text{coll}} = 60\text{ mA}$ ;  $V_{\text{coll}} = 1700\text{ V}$ .



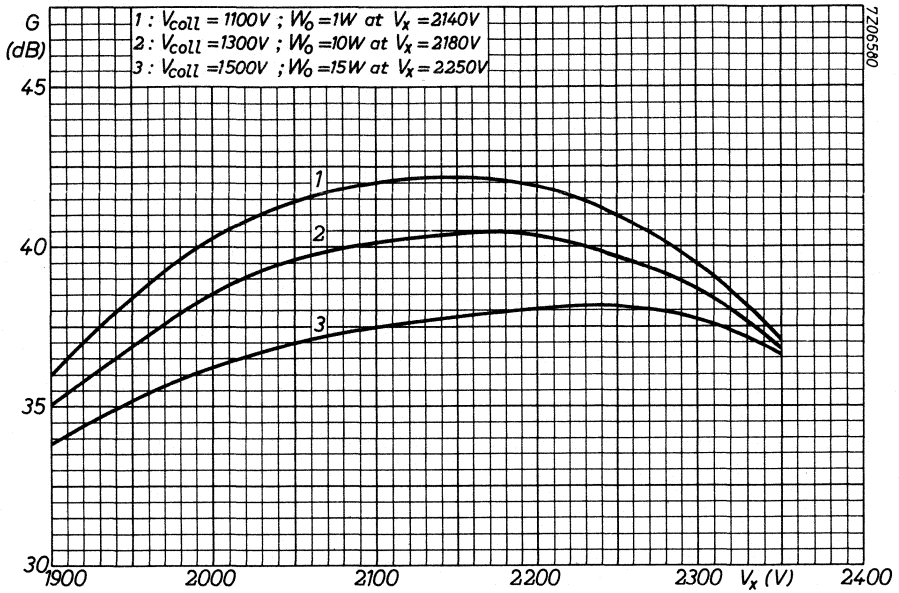

Fig. 10 Ratio of gain to helix voltage;  $f = 3,6$  GHz.

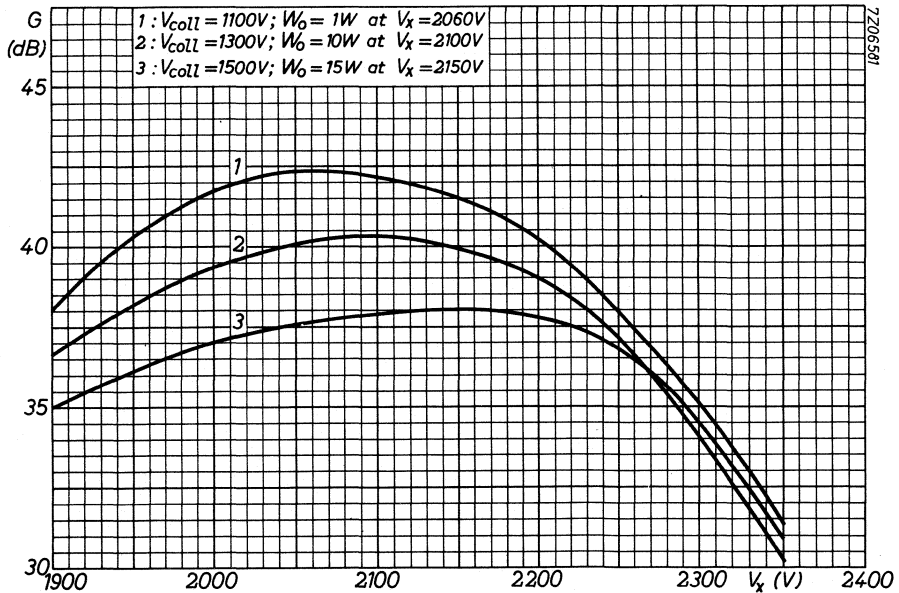

Fig. 11 Ratio of gain to helix voltage;  $f = 4$  GHz.

7Z10222

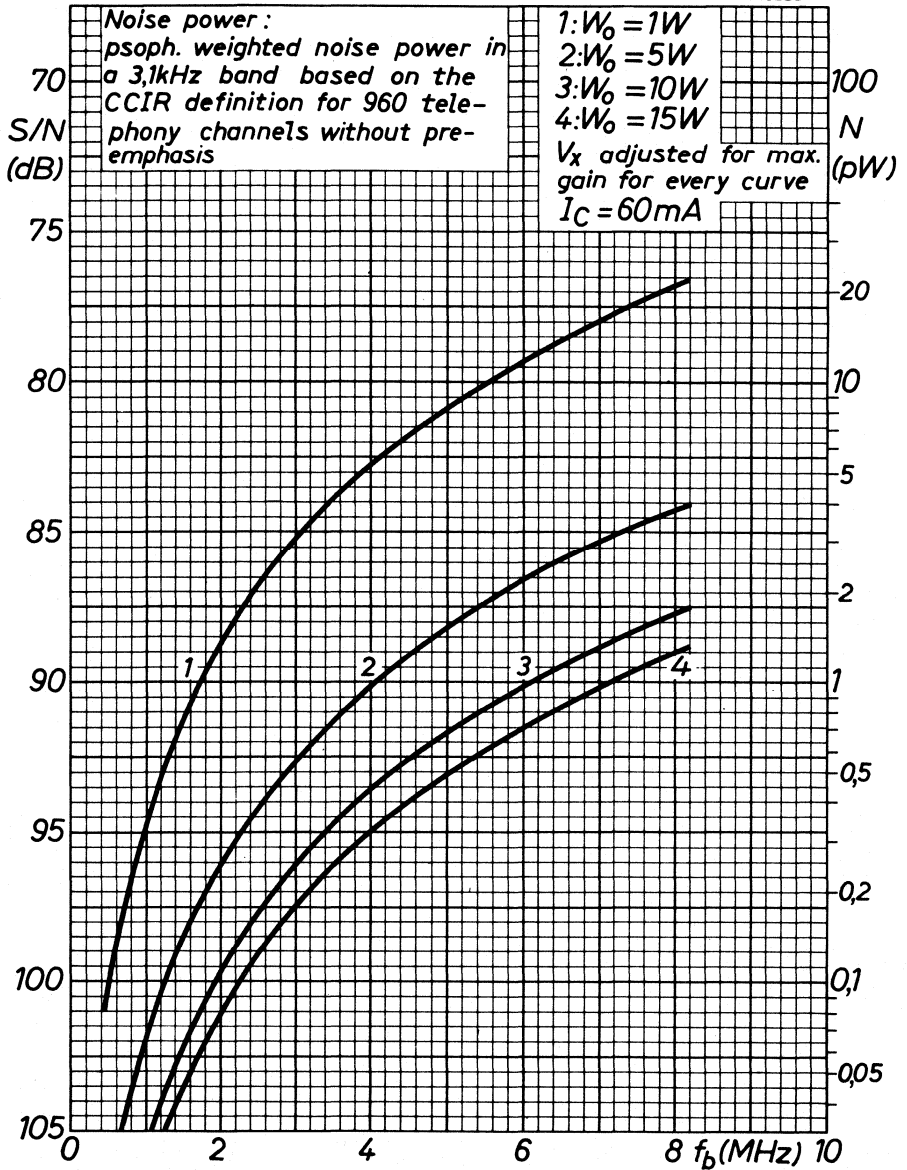

Fig. 12 Ratio of signal-to-noise ratio (FM) to baseband frequency;  $f = 4$  GHz.

7Z10221

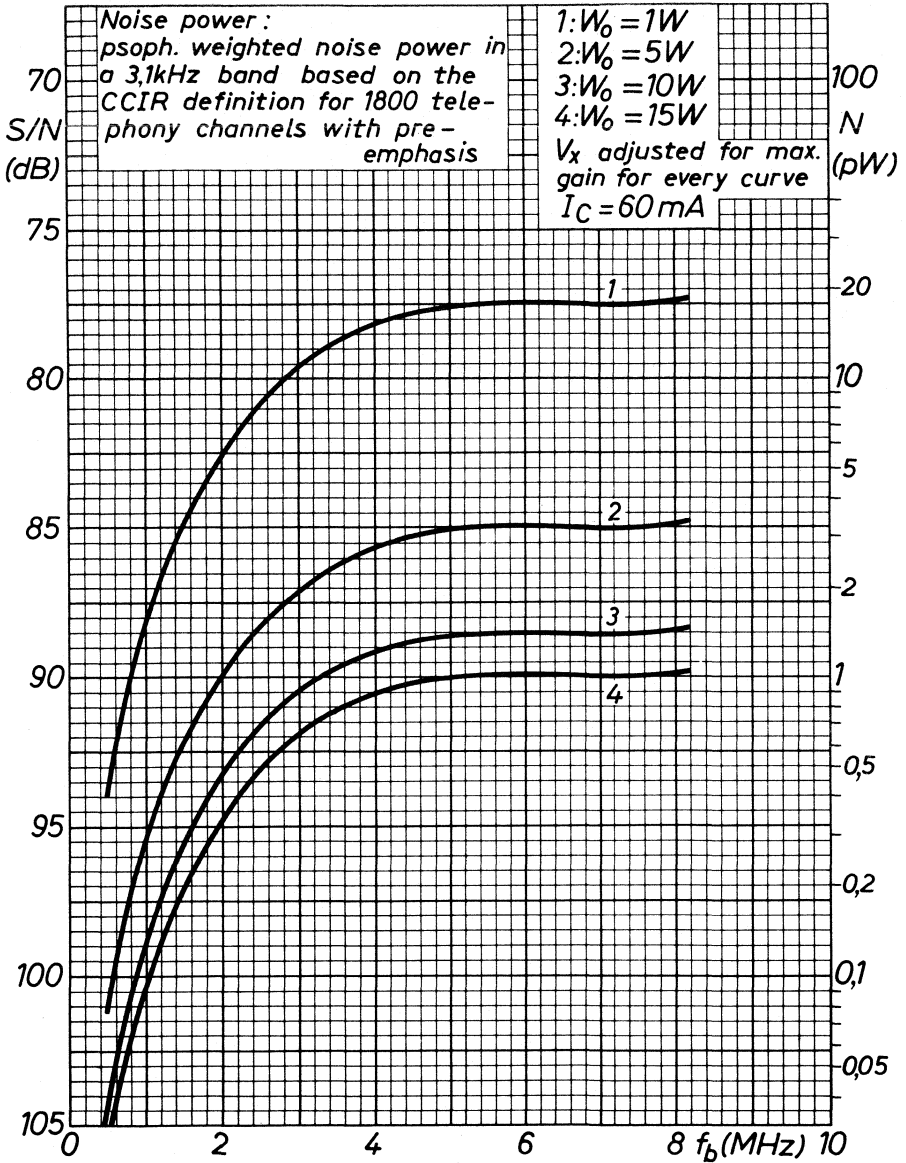

Fig. 13 Ratio of signal-to-noise ratio (FM) to baseband frequency;  $f = 4 GHz$ .

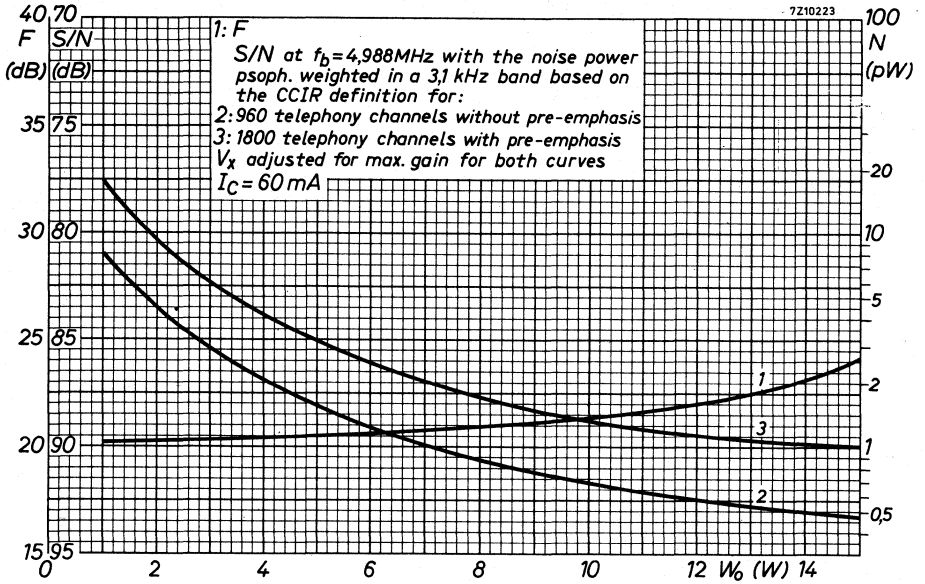

Fig. 14 Ratio of thermal noise (FM) to output power;  $f = 4 \text{ GHz}$ .

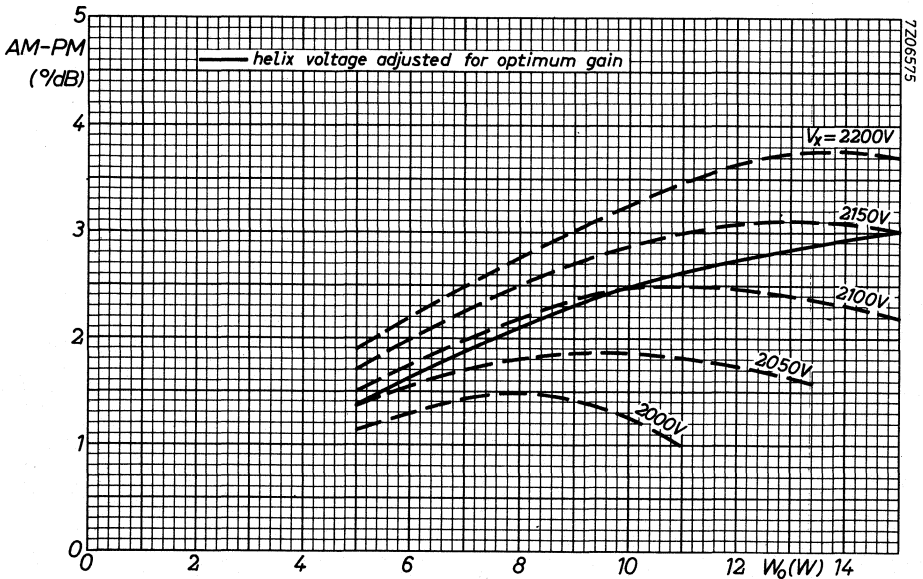

Fig. 15 Ratio of AM-to-PM conversion to output power;  $f = 4 \text{ GHz}$ .

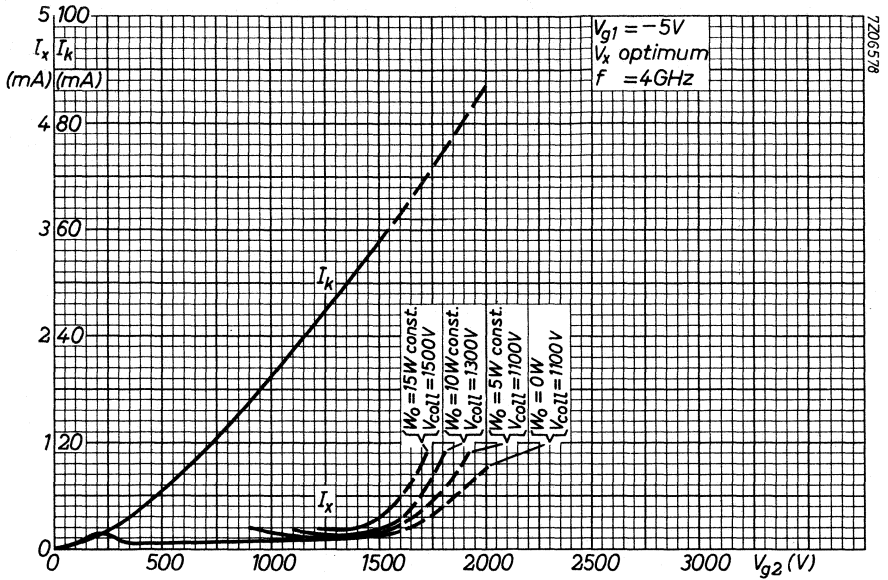

Fig. 16 Ratio of cathode current and helix current to accelerator voltage.

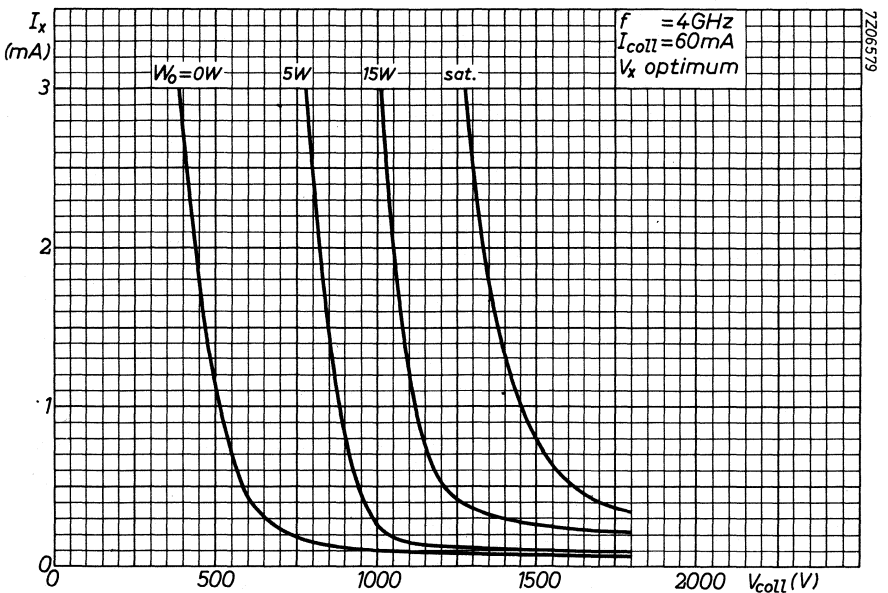

Fig. 17 Ratio of helix current to collector voltage.

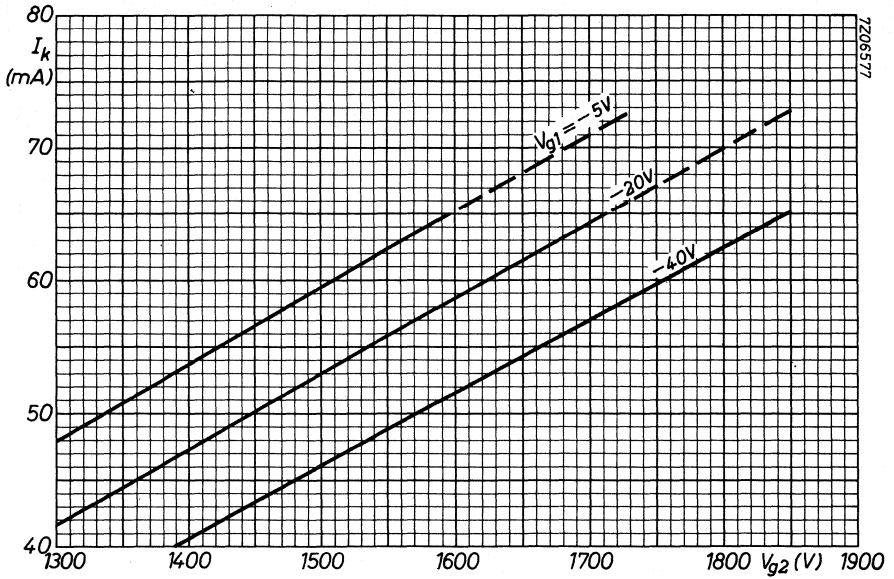

Fig. 18 Ratio of cathode current to accelerator voltage.

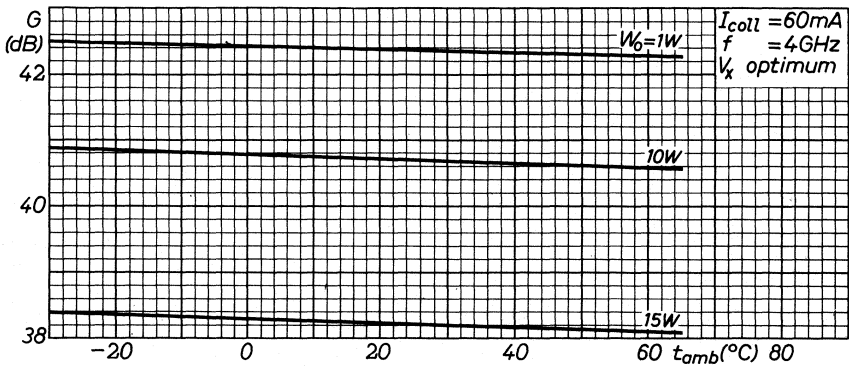
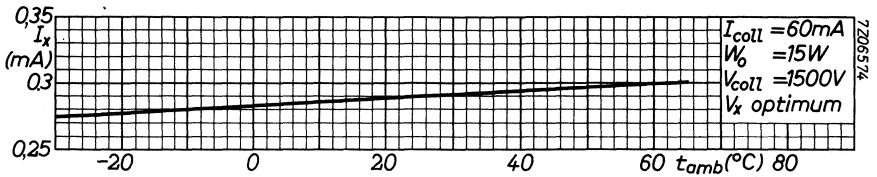

Fig. 19 Ratio of helix current and gain to ambient temperature.

## TRAVELLING-WAVE TUBE

Travelling-wave tube with a periodic permanent magnet mount designed for wide-band microwave link applications.

## QUICK REFERENCE DATA

Frequency range	5,8 to 8,5 GHz
Saturation output power at midband	20 W
Low-level gain at midband	45 dB
Interchangeability	plug-in focus, plug-in match
Construction	unpackaged
tube	glass-metal envelope, metal-ceramic base
mount	periodic permanent magnet

**CATHODE:** dispenser type

**HEATER:** indirect by a.c. or d.c.

When operated on d.c. the cathode must be connected to the positive side of the heater power supply.

Heater voltage	$V_f$	6,3 V $\pm 2\%$
Heater current at $V_f = 6,3$ V	$I_f$	approx. 1 A
Waiting time	$t_w$	min. 2 min

For shorter waiting time when the tube already has been in operation see "Application of voltages".

**COOLING:** By conduction. See also "Design and operating notes", paragraph 6.

## MECHANICAL DATA

Dimensions in mm

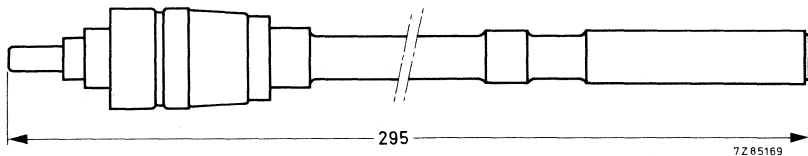

Fig. 1.

**Mounting position:** Any. See "Design and operating notes".

## Mass

of tube	approx.	60 g
of mount	approx.	4,5 kg

**ACCESSORIES (to be ordered separately)**

PPM mount for conduction cooling

type 55337

Waveguide taper (two required)  
to waveguide IEC-R70 (34,85 x 15,80 mm<sup>2</sup>)  
with flange mating IEC-PDR70

type 55338

Waveguide taper (two required)  
to waveguide IEC-R84 (28,50 x 12,62 mm<sup>2</sup>)  
with flange mating IEC-UER84

type 55342

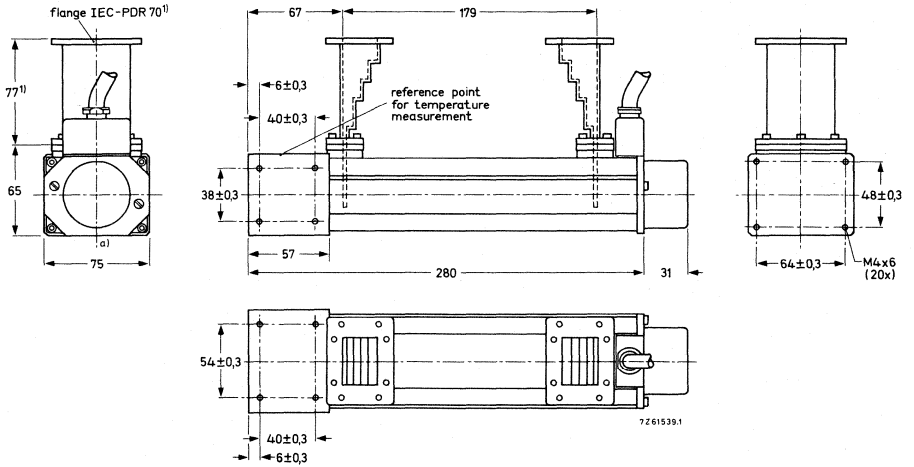

(1) 37 mm for taper 55342 (flange UER-84).

Fig. 2 Mount with conduction (heatsink) cooling and waveguide tapers 55338.



**Connections**

The mount is provided with flying leads, marked with colours.

Heater, cathode	yellow
Heater	brown
Focusing electrode	green
Accelerator	blue
Helix	to be earthed via mount
Collector	red
Safety circuit (closed or opened, when putting on or taking off the mount cap)	two violet leads

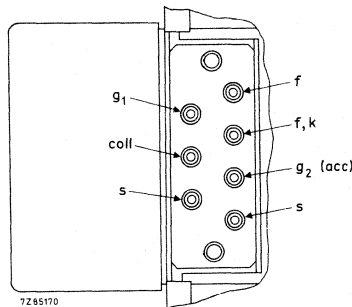

Fig. 3 Connections in cable housing.

**GENERAL CHARACTERISTICS**

Frequency range	f	5,8 to 8,5 GHz
Saturation output power (CW)	$W_{sat}$	20 W (note 1)
Low-level gain	G	45 dB (note 2)
Gain at $W_0 = 15 W$	G	39 dB (note 3)
Thermal noise factor at $W_0 = 15 W$	F	25 dB (note 4)
AM to PM conversion at $W_0 = 15 W$	$k_p$	3 °/dB (note 4)
Cold match at input and output (f = 5,8 to 8,5 GHz)	VSWR	max. 1,5

**NOTES**

1. Typical value measured at  $f = 7,2 GHz$ .  $I_{coll} = 55 mA$ ,  $W_i$  and  $V_x$  optimally adjusted for saturation output power.
2. Typical value measured at  $f = 7,2 GHz$ .  $I_{coll} = 55 mA$ ,  $W_0 < 1 W$ ,  $V_x$  optimally adjusted for low level gain.
3. Typical value measured at  $f = 7,2 GHz$ .  $I_{coll} = 55 mA$ ,  $V_x$  adjusted for optimum gain.
4. Typical value measured at  $f = 6 GHz$ .  $I_{coll} = 55 mA$ ,  $V_x$  adjusted for optimum gain.
5. Measured on the cold tube, i.e. with the beam switched off and without use of any matching device (plug-in match).

## TYPICAL OPERATION

Voltages are specified with respect to the cathode.

Frequency	f		6,0	GHz
Output power	$W_O$	15	10	5 W
Helix voltage (adjusted for optimum gain)	$V_x$	approx. 2950	2900	2900 V
Collector voltage	$V_{coll}$	1500	1450	1300 V
Focusing electrode voltage	$V_{g1}$	-6	-6	-6 V
Collector current	$I_{coll}$	55	55	55 mA
Gain	G	41	43	45 dB
Accelerator voltage*	$V_{g2}$	approx. 2050	2050	2050 V
Accelerator current	$I_{g2}$	< 0,1	< 0,1	< 0,1 mA
Helix current (plug-in focus)	$I_x$	0,8	0,8	0,5 mA
Thermal noise factor	F	25	23	22 dB
AM to PM conversion	$k_p$	3,0	2,5	1,5 °/dB

Frequency	f		7,0	GHz
Output power	$W_O$	15	10	5 W
Helix voltage (adjusted for optimum gain)	$V_x$	approx. 2850	2800	2800 V
Collector voltage	$V_{coll}$	1500	1450	1300 V
Focusing electrode voltage	$V_{g1}$	-6	-6	-6 V
Collector current	$I_{coll}$	55	55	55 mA
Gain	G	39	42	44 dB
Accelerator voltage*	$V_{g2}$	approx. 2050	2050	2050 V
Accelerator current	$I_{g2}$	< 0,1	< 0,1	< 0,1 mA
Helix current (plug-in focus)	$I_x$	0,8	0,8	0,5 mA
Thermal noise factor	F	25	23	22 dB
AM to FM conversion	$k_p$	3,0	2,5	1,5 °/dB

\* To be adjusted for indicated collector current.

Frequency	$f$	8,0	GHz
Output power	$W_o$	10	5 W
Helix voltage (adjusted for optimum gain)	$V_x$	approx. 2750	2750 V
Collector voltage		1540	1300 V
Focusing electrode voltage	$V_{g1}$	-6	-6 V
Collector current	$I_{coll}$	55	55 mA
Gain	$G$	38	40 dB
Accelerator voltage*	$V_{g2}$	approx. 2050	2050 V
Accelerator current	$I_{g2}$	< 0,1	< 0,1 mA
Helix current (plug-in focus)	$I_x$	0,8	0,5 mA
Thermal noise factor	$F$	23	22 dB
AM to PM conversion	$k_p$	2,5	1,5 °/dB

**LIMITING VALUES** (Absolute maximum rating system)

Voltages are with respect to the cathode unless otherwise specified.

Focusing electrode voltage	$-V_{g1}$	min.	0 V
		max.	50 V
Accelerator voltage	$V_{g2}$	max.	2700 V
Helix voltage	$V_x$	max.	3300 V
Collector to helix voltage	$V_{coll-x}$	max.	2500 V
Cathode current	$I_k$	max.	60 mA
Accelerator current	$I_{g2}$	max.	0,3 mA
Helix current	$I_x$	max.	3 mA
R.F. input level	$W_i$	max.	100 mW
Collector dissipation at $T_{amb} = 65\text{ °C}$	$W_{coll}$	max.	90 W
Power reflected from load (to avoid overheating of the helix)		max.	2 W
Cooler temperature at reference point	$T$	max.	150 °C

\* To be adjusted for indicated collector current.

## DESIGN AND OPERATING NOTES

### 1. Installation of the mount

Two main methods may be discerned:

- (a) Fixing the mount relative to the microwave circuit by only connecting the waveguide tapers to the input and output sides of the circuit.
- (b) Employing (a) and establishing additional support by fastening the mount to the rack with clamps. In this case it is recommended that a short piece of flexible waveguide be used at the input and output sides to prevent excessive strain on the mount via the tapers, unless very careful alignment of the waveguides can be assured.

Possible forces on the waveguides must not produce a moment greater than 20 Nm at the flanges.

#### 1.1 Mount

The mount has no movable parts. If clamps are used (method b) the slightly larger dimensions of the cooler as compared to the main part of the mount must be considered.

#### 1.2 Magnetic shielding

The periodic permanent magnet is completely shielded. This implies that no additional measures need be taken to prevent the magnetic properties of the mount from being affected by external magnetic fields. The mount will not influence surrounding equipment which is susceptible to stray magnetic fields. Several mounts may be placed side by side without disturbing the focusing qualities. Isolators may be installed quite near to the mount.

#### *Warning*

*If any part of the shielding is removed, the magnetic properties of the mount may be disturbed irreversibly.*

### 2. Installation of the tube

Unlock the mount cap (see outline drawing) by turning it slightly counter-clockwise. The cap can then easily be removed, and the tube inserted by carefully pushing it in. Finally put the cap on the mount again, and lock by turning it clockwise. These instructions also apply (in the reverse order) for taking the tube out of the mount.

### 3. Safety

The supply voltages are fed to the tube via the mount cap. When the cap is unlocked all voltages are removed from the tube. The two violet leads can be incorporated into an additional safety circuit which switches the voltages off at the power supply if the cap is unlocked. Thus the voltages can also be removed from the mount. The mount should always be earthed.

4. Power supply

An example of a supply circuit for 5, 10 and 15 W operation is given in Fig. 4.

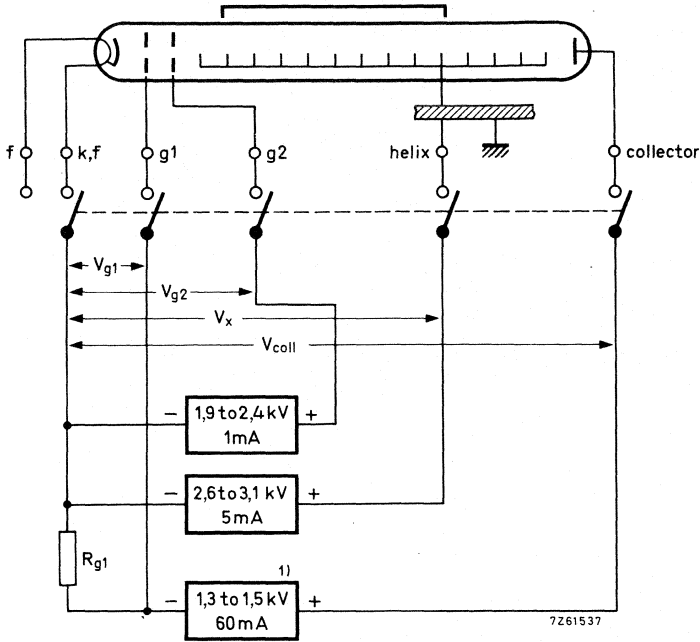

Fig. 4.

Design ranges for the power supply (electrode voltages with respect to cathode)

	min.	max.
Accelerator voltage	1900	2400 V
Accelerator current		0,3 mA
Helix voltage*	2600	3100 V
Helix current		3 mA

The collector voltage is set at a fixed voltage dependent on the output power level.

Output power level	$W_o$	5	10	15	$W_{sat}$	W
Collector voltage	$V_{coll}$	1300	1450	1500	1700	V
Collector current	$I_{coll}$	55	55	55	55	mA
Focusing electrode voltage	$V_{g1}$	-6	-6	-6	-6	V

\* At saturation the helix voltage may reach 3200 V.

## 5. Cooling

Tube and mount need no artificial means of cooling. Natural cooling of the collector has been made possible by depression of the collector potential with respect to the helix and by ensuring adequate heat transfer from the collector to the environment.

Under typical operating conditions and at an ambient temperature of not more than 65 °C, the cooler temperature at the reference point (see Fig. 2) is well below the limit, provided an aluminium heatsink of 300 x 300 x 6 mm is mounted on one of the cooler surfaces. The heatsink is best fixed with its centre coinciding with that of the cooler, and in a vertical position. The mount itself may have any position in the equipment.

Other heatsink configurations may be employed. It will then be necessary to check the temperatures reached at the reference point under extreme conditions e.g. 65 °C ambient temperature.

## 6. Application of voltages

### 6.1 *Switching-on procedure for new tubes*

- 6.1.1 Apply the heater voltage for the specified waiting time.
- 6.1.2 Apply the rated voltages to the collector, the helix, the accelerator (and in case of a separate supply to the focusing electrode) simultaneously (see Notes).
- 6.1.3 Adjust the accelerator voltage to obtain a collector current of 55 mA.
- 6.1.4 Apply the r.f. input signal, adjust the level to obtain the required output power while simultaneously adjusting the helix voltage for optimum gain.

### 6.2 *Readjustment during life*

During life the collector current may decrease. A readjustment of the accelerator voltage to obtain  $I_{\text{coll}} = 55 \text{ mA}$  will then be necessary.

### 6.3 *Switching-off procedure*

All voltages should be switched off simultaneously.  
If this is not feasible, do as described under "Notes".

### 6.4 *Switching-on procedure after interruption of voltage (also see the Notes)*

- 6.4.1 Interruption of less than 40 s: Switch on all voltages simultaneously.
- 6.4.2 Interruption of more than 40 s but less than 1 week: Apply the heater voltage for min. 40 s, then apply all other voltages simultaneously.
- 6.4.3 Interruption of more than 1 week: Apply the heater voltage for the specified waiting time of 2 min. Apply all other voltages simultaneously.

**NOTES**

When the voltages cannot be switched simultaneously all the cathode current may flow to the accelerator or the helix. If this condition lasts for more than 10 ms, it may cause permanent damage to the tube. The remedy is to switch the accelerator voltage on after the other electrode voltages, or off before the other electrode voltages.

**7. Input and output circuit and group delay**

In order to avoid phase distortions due to long-line effect, the insertion of an isolator between tube and antenna, and another between tube and pre-stage is strongly recommended. The isolators should be positioned as close to the tube as possible.

If isolators with a VSWR of less than 1,05 are used at a short distance from the tube, the reflections result in a variation of the group delay of less than 0,2 nanoseconds over a band of 20 MHz.

It may be noted that the difference between the voltage reflection coefficients of the hot and the cold tube (i.e. with respectively without electron beam) is less than 0,2 for the input as well as the output side, measured at an output power level of 5 W or more.

**8. Environmental conditions**

Ambient temperature

storage

$T_{amb}$	min.	-60 °C
	max.	+65 °C

operation

$T_{amb}$	min.	-30 °C
	max.	+65 °C

Relative humidity

0 to 95 %

The tube and mount resist fungus attack.



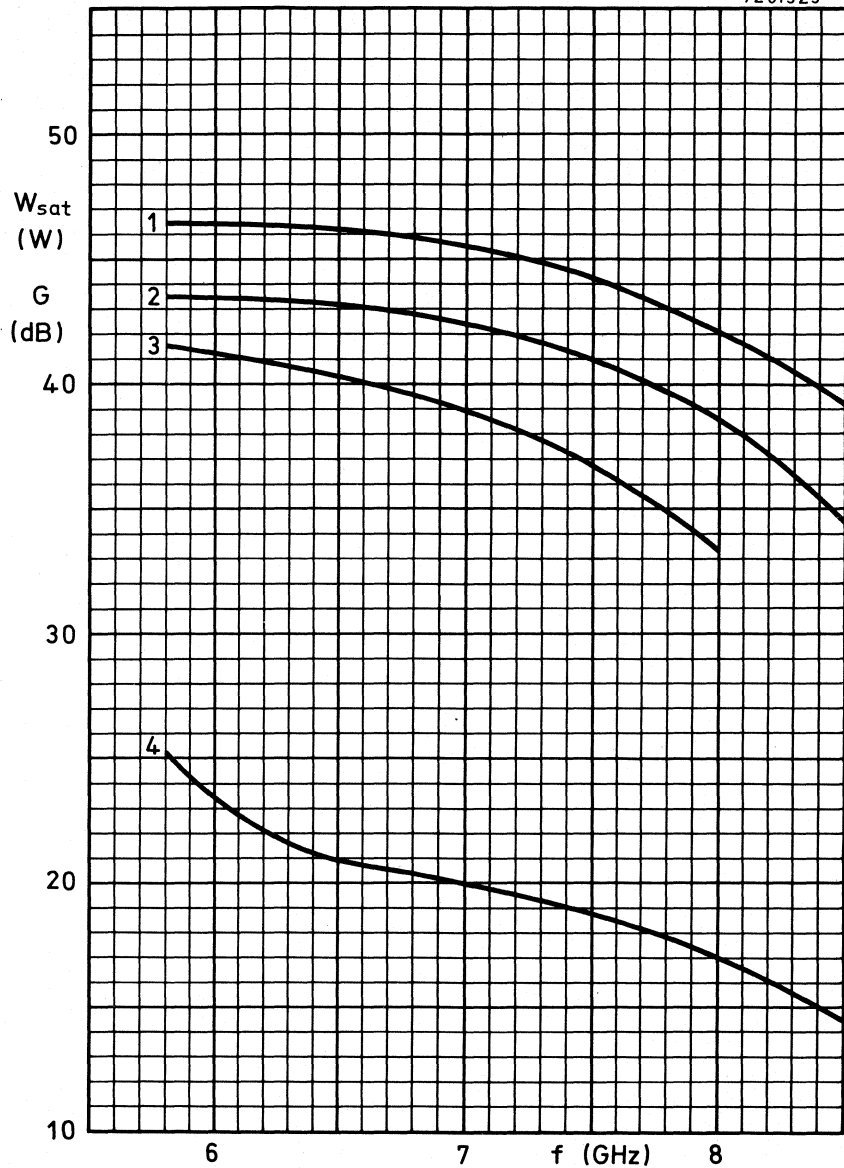

Fig. 5 Ratio of gain and saturation power to frequency.

1. Gain at  $W_o = 1 \text{ W}$ ;  $V_{\text{coll}} = 1300 \text{ V}$ ;  $V_f = 6,3 \text{ V}$
2. Gain at  $W_o = 10 \text{ W}$ ;  $V_{\text{coll}} = 1450 \text{ V}$ ;  $V_{g1} = -6 \text{ V}$
3. Gain at  $W_o = 15 \text{ W}$ ;  $V_{\text{coll}} = 1500 \text{ V}$ ;  $I_{\text{coll}} = 55 \text{ mA}$
4.  $W_o = W_{\text{sat}}$   $V_{\text{coll}} = 1700 \text{ V}$ ;  $V_x = \text{opt.}$



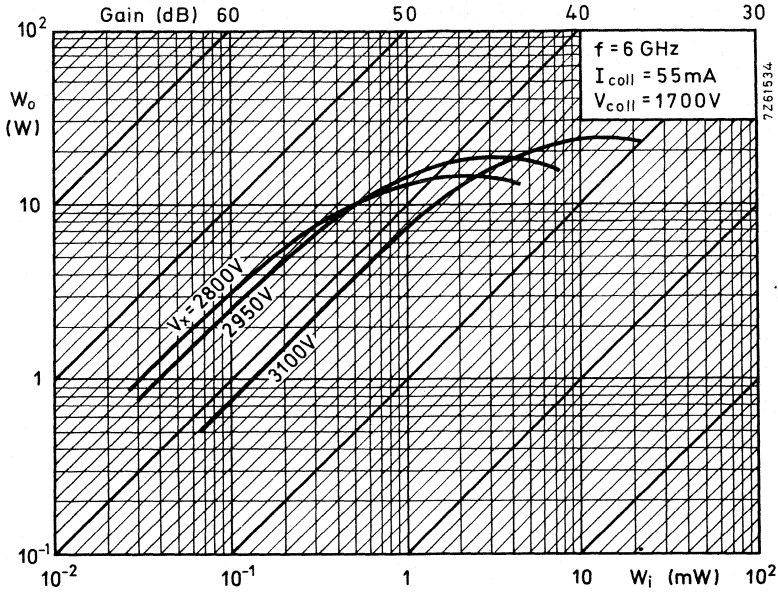

Fig. 6 Ratio of output power to input power;  $f = 6$  GHz.

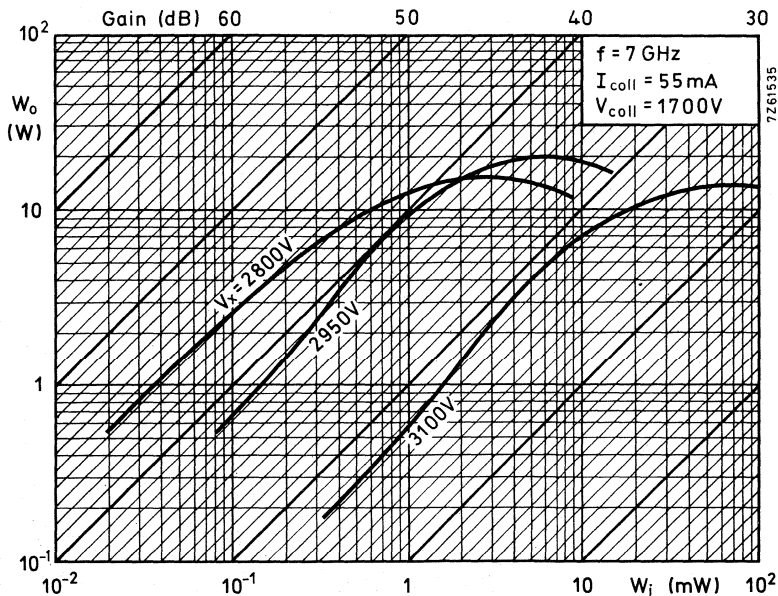

Fig. 7 Ratio of output power to input power;  $f = 7$  GHz.

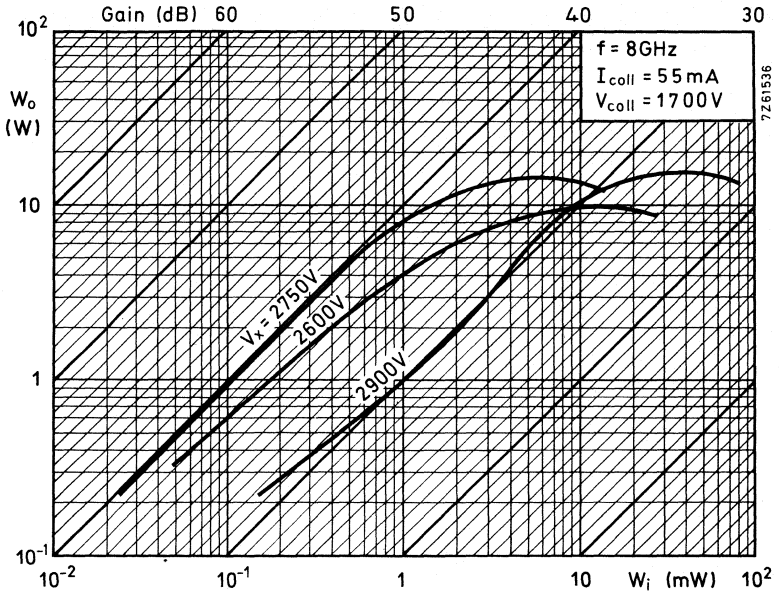

Fig. 8 Ratio of output power to input power.

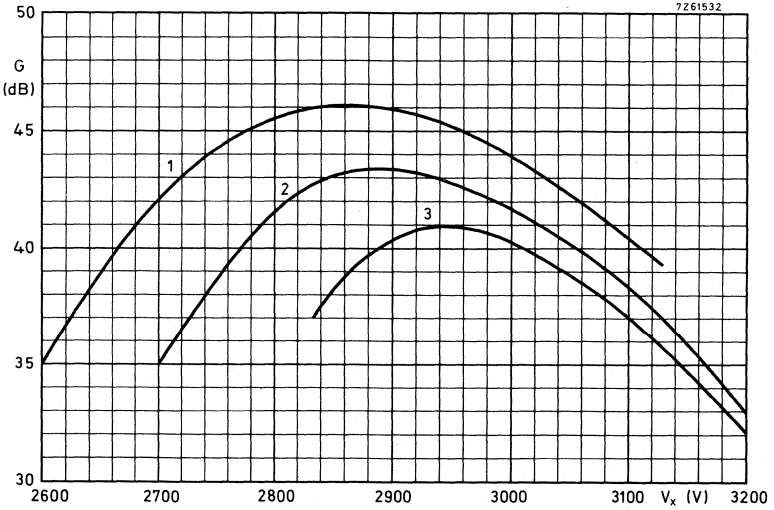

Fig. 9 Ratio of gain to helix voltage;  $f = 6\text{ GHz}$ .  
 1.  $W_o = 1\text{ W}$ ;  $V_{\text{coll}} = 1300\text{ V}$ ;  $I_{\text{coll}} = 55\text{ mA}$ .  
 2.  $W_o = 10\text{ W}$ ;  $V_{\text{coll}} = 1450\text{ V}$ ;  $I_{\text{coll}} = 55\text{ mA}$ .  
 3.  $W_o = 15\text{ W}$ ;  $V_{\text{coll}} = 1500\text{ V}$ ;  $I_{\text{coll}} = 55\text{ mA}$ .

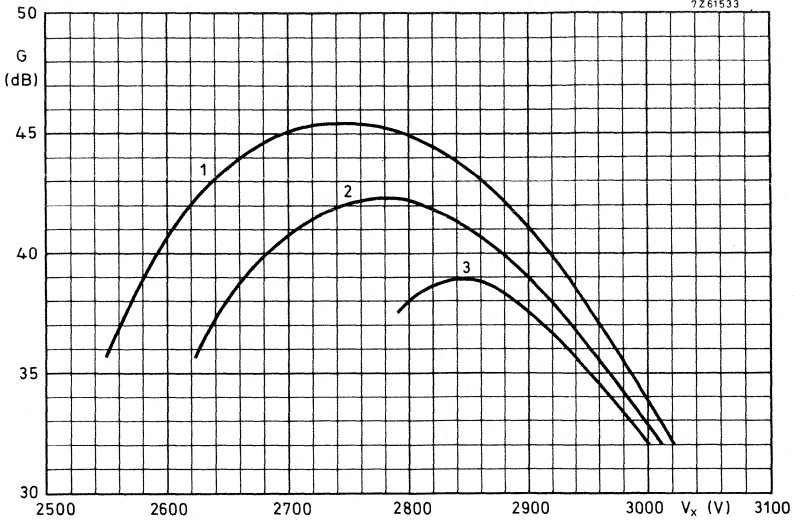

Fig. 10 Ratio of gain to helix voltage;  $f = 7$  GHz.

1.  $W_o = 1$  W;  $V_{coll} = 1300$  V;  $I_{coll} = 55$  mA
2.  $W_o = 10$  W;  $V_{coll} = 1450$  V;  $I_{coll} = 55$  mA
3.  $W_o = 15$  W;  $V_{coll} = 1500$  V;  $I_{coll} = 55$  mA.

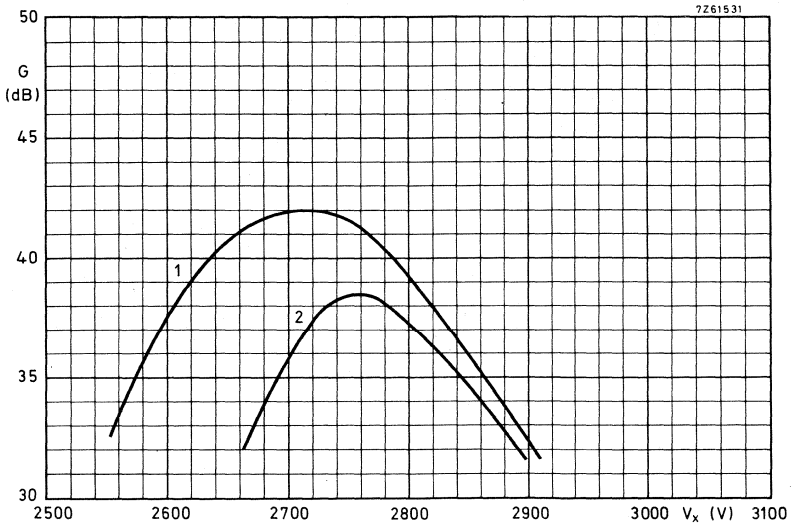

Fig. 11 Ratio of gain to helix voltage;  $f = 8$  GHz.

1.  $W_o = 1$  W;  $V_{coll} = 1300$  V;  $I_{coll} = 55$  mA
2.  $W_o = 10$  W;  $V_{coll} = 1450$  V;  $I_{coll} = 55$  mA.



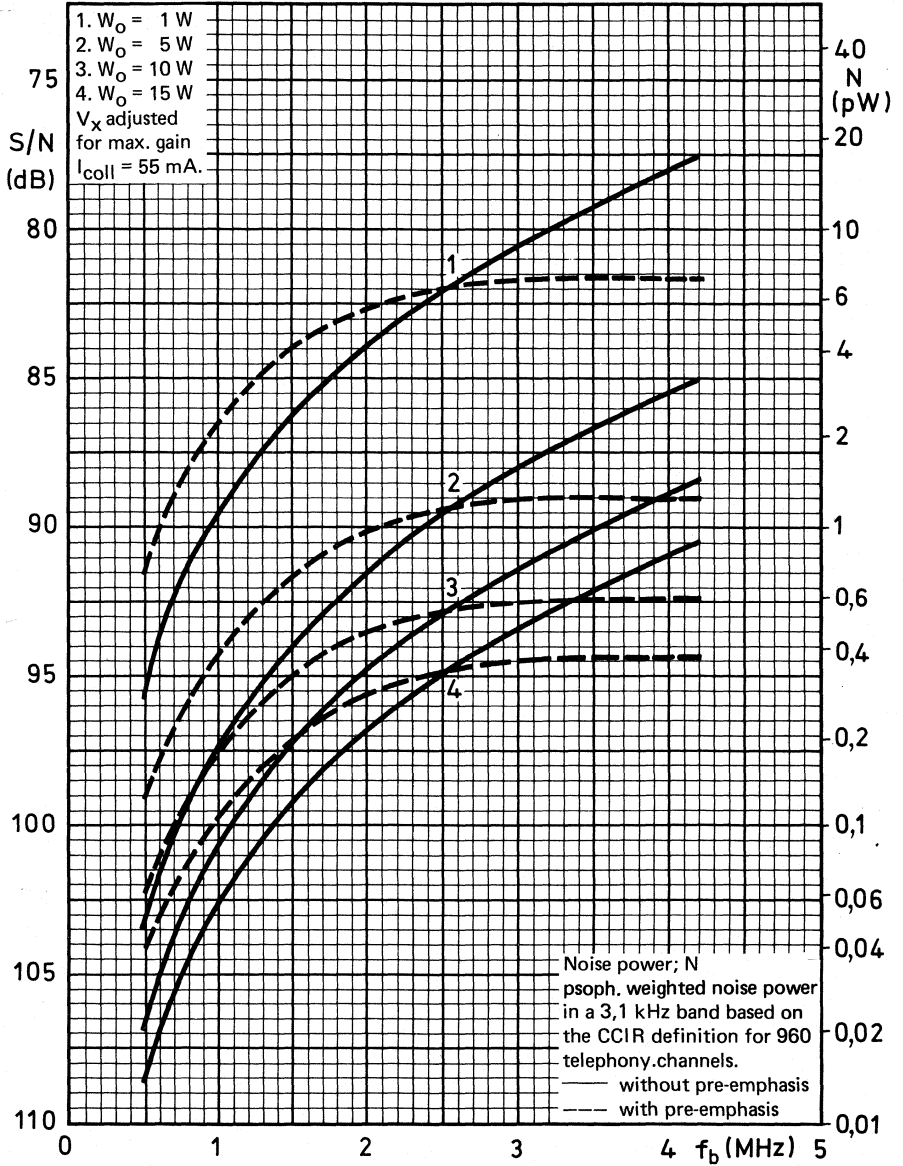

Fig. 12 Ratio of signal-to-noise ratio to baseband frequency;  $f = 6\text{ GHz}$ .

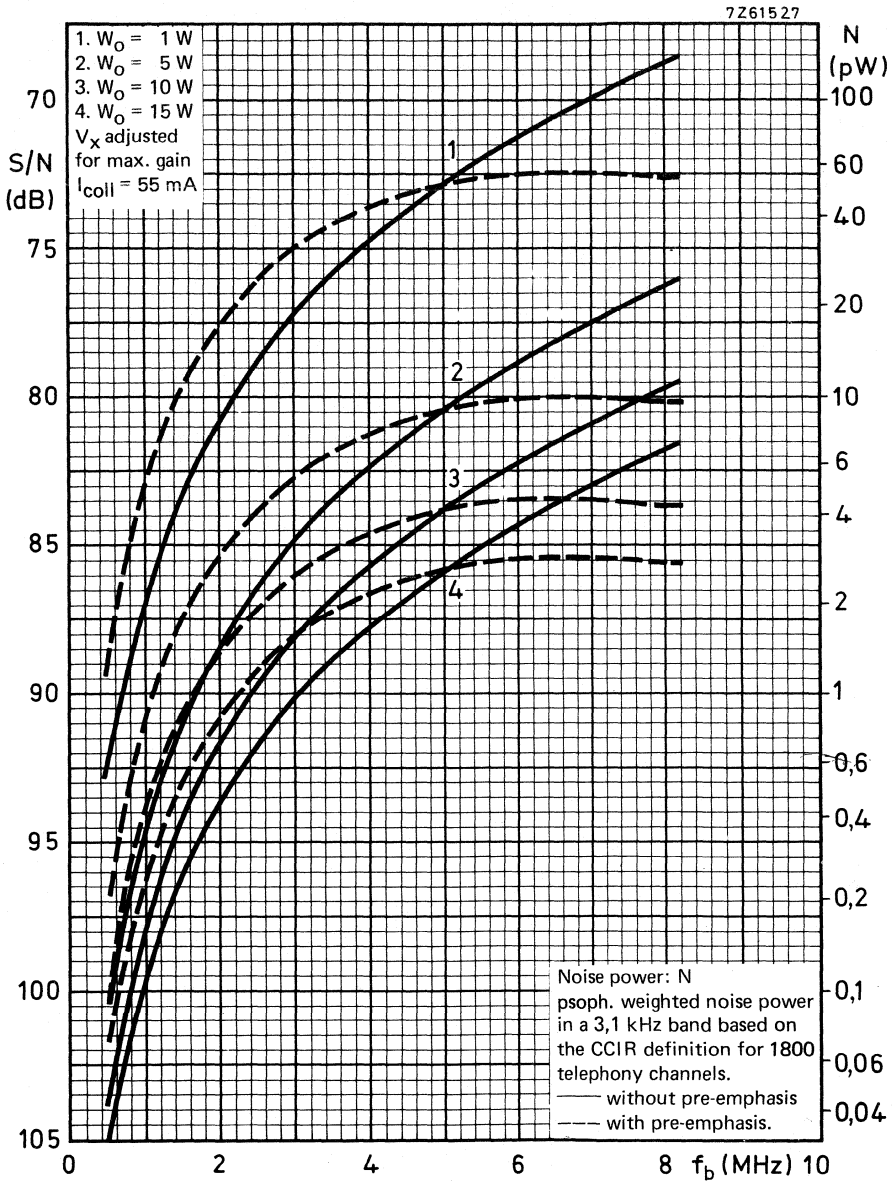

Fig. 13 Ratio of signal-to-noise ratio (FM) to baseband frequency;  $f = 6 \text{ GHz}$ .

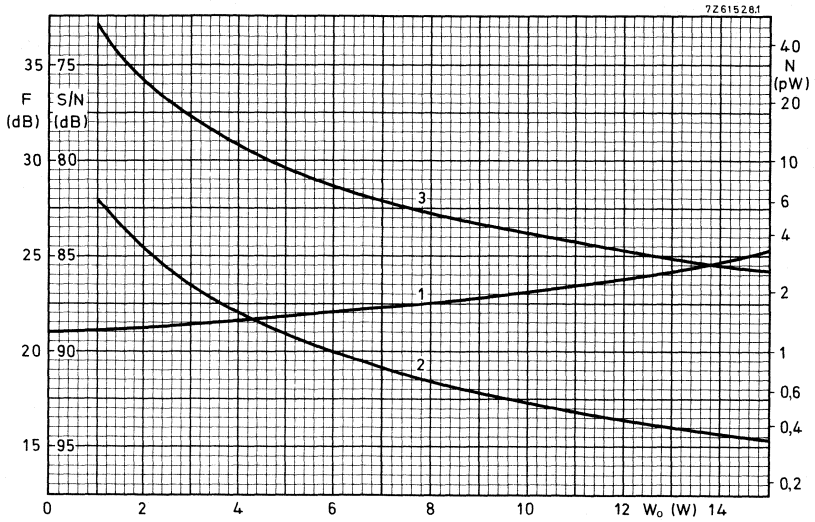

Fig. 14 Ratio of thermal noise (FM) to output power;  $f = 6$  GHz.

1.  $F$  at  $I_{coll} = 55$  mA  
S/N with the noise psoph.  
weighted in a 3.1 kHz band based  
on the CCIR definition for:
2. 960 channels at  $f_b = 2,546$  MHz
3. 1800 channels at  $f_b = 4,988$  MHz  
 $V_x$  adjusted for max. gain.

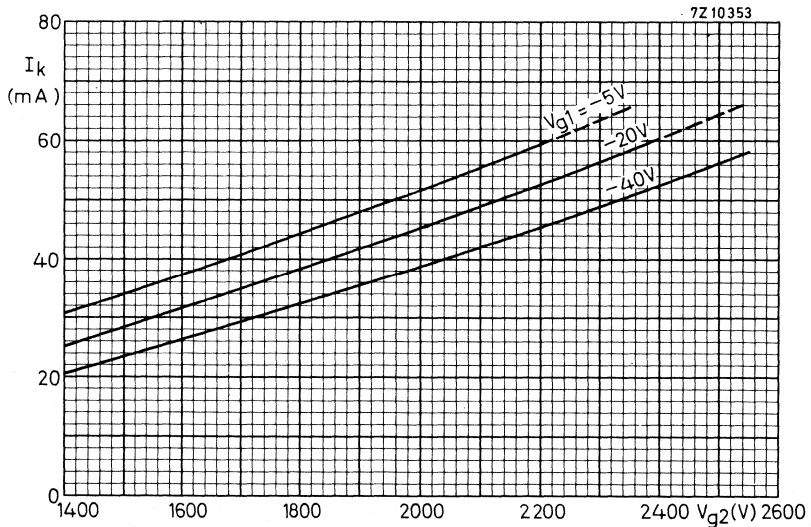

Fig. 15 Ratio of cathode current to accelerator voltage.



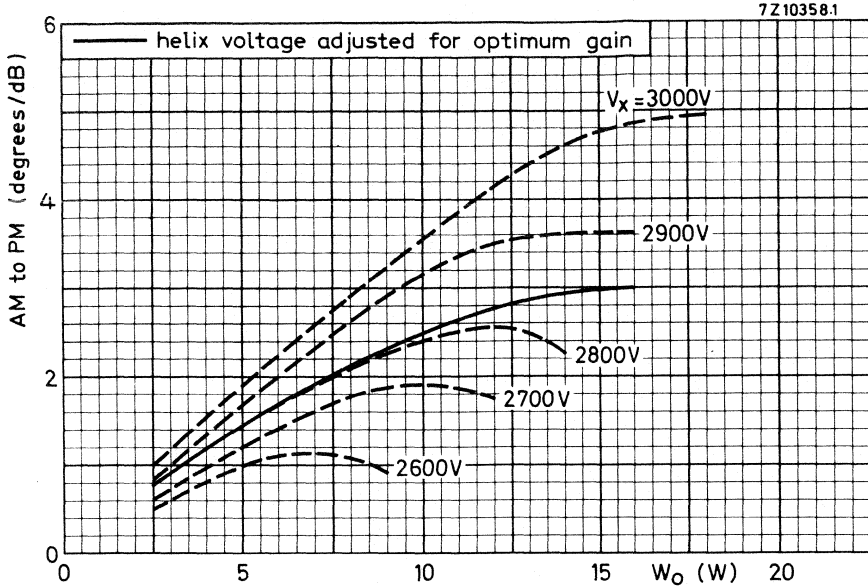

Fig. 16 Ratio of AM-to-PM conversion to output power;  $f = 6$  GHz.

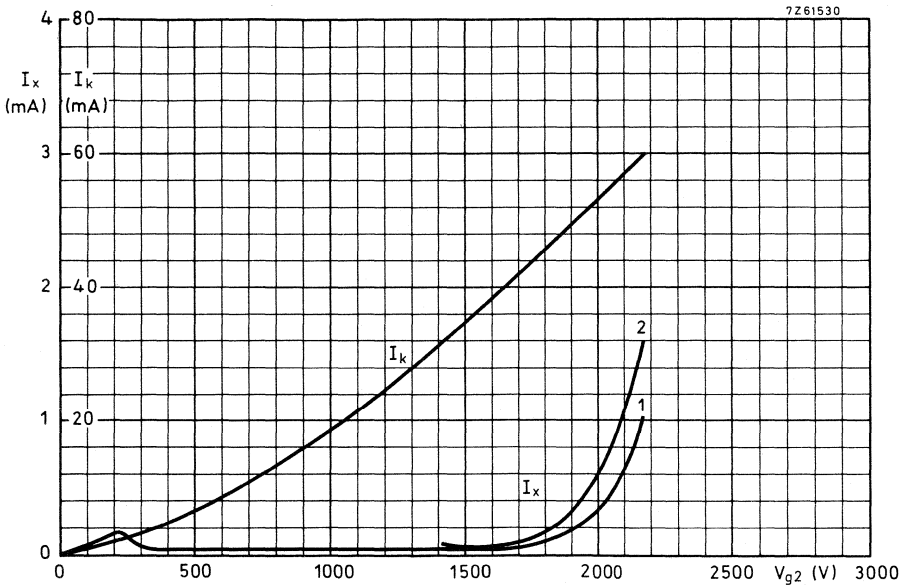

Fig. 17 Ratio of cathode current and helix current to accelerator voltage.

$V_{g1} = -6$  V  
 $f = 6$  GHz

1  $\left\{ \begin{array}{l} W_o = 0 \text{ W} \\ V_{coll} = 1300 \text{ V} \\ V_x = 2850 \text{ V} \end{array} \right.$

2  $\left\{ \begin{array}{l} W_o = 10 \text{ W} \\ V_{coll} = 1450 \text{ V} \\ V_x = \text{optimum} \end{array} \right.$

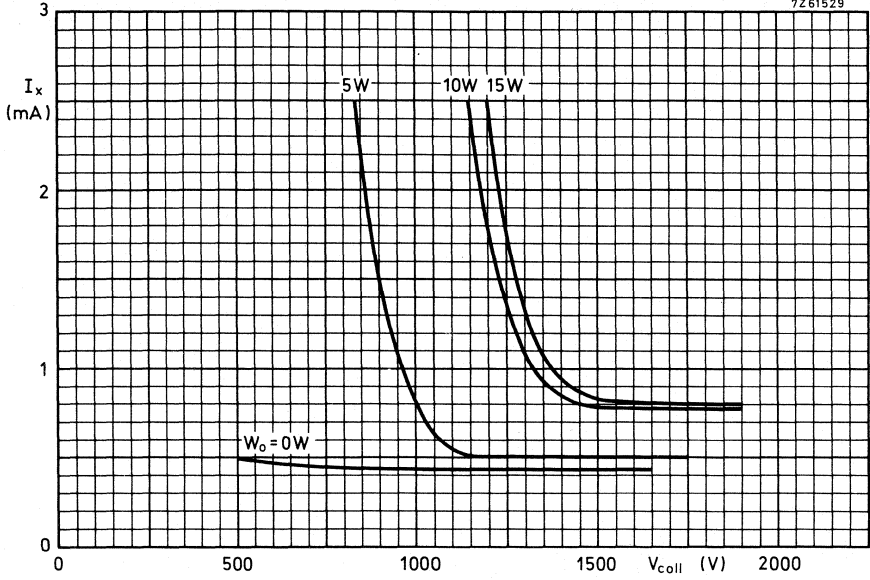

Fig. 18 Ratio of helix current to collector voltage.

$f = 6$  GHz  
 $V_x = \text{optimum}$   
 $I_{coll} = 55$  mA  
 $V_{g1} = -6$  V



## TRAVELLING-WAVE TUBE

Travelling-wave tube with a periodic permanent magnet mount designed for wide-band microwave link applications.

### QUICK REFERENCE DATA

Frequency range	7,0 to 8,0	8,0 to 8,5 GHz
Saturation output power at midband	22	17 W
Low-level gain at midband	45	42 dB
Interchangeability	plug-in focus, plug-in match	
Construction tube	unpacked glass-metal envelope, metal-ceramic base	
mount	periodic permanent magnet	

**CATHODE:** dispenser type

**HEATING:** indirect by a.c. or d.c.

When operated on d.c. the cathode must be connected to the positive side of the heater power supply.

Heater voltage  $V_f$  6,3 V  $\pm$  2%

Heater current at  $V_f = 6,3$  V  $I_f$  approx. 1 A

Waiting time  $t_w$  min. 2 min

For shorter waiting time when the tube already has been in operation see "Application of voltages".

**COOLING:** By conduction. See also "Design and operating notes", paragraph 6.

### MECHANICAL DATA

Dimensions in mm

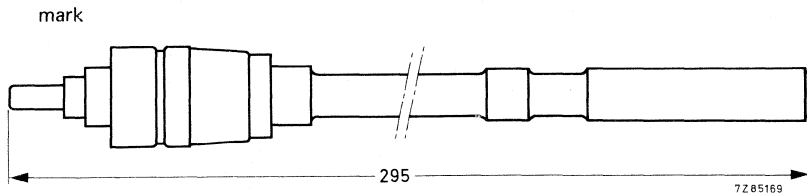

**Mounting position:** The tube is provided with a mark on the accelerator terminal. For optimum performance the tube must be inserted with this mark in line with the centre line a) of the cable housing on the mount. See Fig. 2.

### Mass

of tube approx. 60 g  
of mount approx. 4,5 kg

**ACCESSORIES** (to be ordered separately)

PPM mount for conduction cooling

type 55361

Waveguide taper (two required)  
to waveguide IEC-R70 (34,85 x 15,80 mm)  
with flange mating IEC-PDR70

type 55338

Waveguide taper (two required)  
to waveguide IEC-R84 (28,50 x 12,62 mm)  
with flange mating IEC-UER84

type 55342

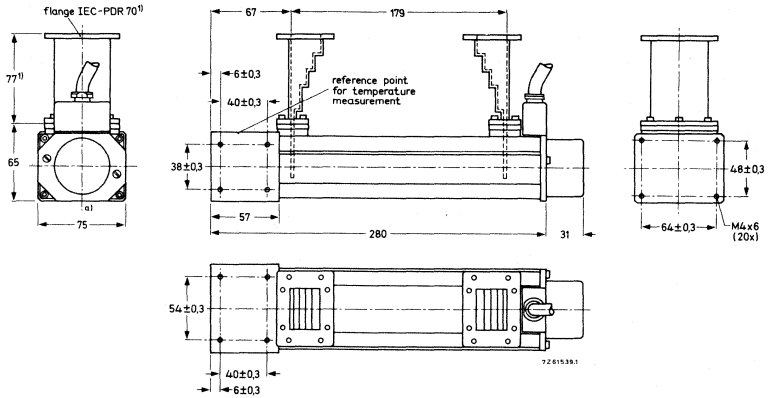

(1) 37 mm for taper 55342 (flange UER84)

Fig. 2 Mount with conduction (heatsink) cooling and waveguide tapers type 55338.

**Connections**

The mount is provided with flying leads, marked with colours.

Heater, cathode	yellow
Heater	brown
Focusing electrode	green
Accelerator	blue
Helix	to be earthed via mount
Collector	red
Safety circuit (closed or opened, when putting on or off the mount cap)	two violet leads.

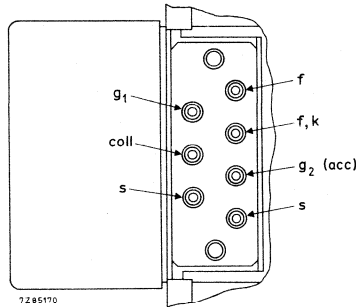

Fig. 3 Connections in cable housing.

**GENERAL CHARACTERISTICS**

Frequency range	f	7,0 to 8,0	8,0 to 8,5 GHz
Saturation output power (CW)	$W_{sat}$	22	17 W
Low-level gain	G	45	42 dB
Gain			
at $W_o = 15 W$	G	41	dB
at $W_o = 10 W$	G		39 dB
Thermal noise factor			
at $W_o = 15 W$	F	24	dB
at $W_o = 10 W$	F		24 dB
AM to FM conversion at $W_o = 15 W$	$k_p$	3	°/dB
Cold match at input and output (f = 7,0 to 8,5 GHz)	VSWR		max. 1,5

**Notes**

1. Typical values measured at f = 7,5 GHz,  $I_{coll} = 55 mA$ , or f = 8,3 GHz,  $I_{coll} = 52,5 mA$  respectively,  $W_i$  and  $V_x$  optimally adjusted for saturation output power.
2. Typical values measured at f = 7,5 GHz,  $I_{coll} = 55 mA$ , or f = 8,3 GHz,  $I_{coll} = 52,5 mA$  respectively,  $W_o < 1 W$ ,  $V_x$  optimally adjusted for low level gain.
3. Typical value measured at f = 7,5 GHz,  $I_{coll} = 55 mA$ , or f = 8,3 GHz,  $I_{coll} = 52,5 mA$  respectively,  $V_x$  adjusted for optimum gain.
4. Measured on the cold tube, i.e. with the beam switched off and without use of any matching device (plug-in match).

**TYPICAL OPERATION**

Voltages are specified with respect to the cathode.

Frequency	f		7,0	GHz
Output power	$W_o$		15    10	5 W
Helix voltage (adjusted for optimum gain)	$V_x$	approx.	3100    3000	2950 V
Collector voltage	$V_{coll}$		1500    1450	1300 V
Focusing electrode voltage	$V_{g1}$		-6    -6	-6 V
Collector current	$I_{coll}$		55,0    52,5	52,5 mA
Gain	G		42    43	45 dB
Accelerator voltage*	$V_{g2}$	approx.	2050    2000	2000 V
Accelerator current	$I_{g2}$		< 0,1    < 0,1	< 0,1 mA
Helix current (plug-in focus)	$I_x$		1,0    0,7	0,5 mA
Thermal noise factor	F		24    24	22 dB
AM to FM conversion	$k_p$		3,0    2,5	1,5 °/dB

Frequency	f		8,0	GHz
Output power	$W_o$		15    10	5 W
Helix voltage (adjusted for optimum gain)	$V_x$	approx.	3050    2950	2900 V
Collector voltage	$V_{coll}$		1500    1450	1300 V
Focusing electrode voltage	$V_{g1}$		-6    -6	-6 V
Collector current	$I_{coll}$		55,0    52,5	52,5 mA
Gain	G		39    40	43 dB
Accelerator voltage*	$V_{g2}$	approx.	2050    2000	2000 V
Accelerator current	$I_{g2}$		< 0,1    < 0,1	< 0,1 mA
Helix current (plug-in focus)	$I_x$		1,0    0,7	0,5 mA
Thermal noise factor	F		24    24	22 dB
AM to PM conversion	$k_p$		3,0    2,5	1,5 °/dB

\* To be adjusted for indicated collector current.

Frequency	f	8,5	GHz
Output power	$W_o$	10	5 W
Helix voltage (adjusted for optimum gain)	$V_x$ approx.	2900	2900 V
Collector voltage	$V_{coll}$	1450	1300 V
Focusing electrode voltage	$V_{g1}$	-6	-6 V
Collector current	$I_{coll}$	52,5	52,5 mA
Gain	G	37	40 dB
Accelerator voltage*	$V_{g2}$ approx.	2000	2000 V
Accelerator current	$I_{g2}$	< 0,1	< 0,1 mA
Helix current (plug-in focus)	$I_x$	0,7	0,5 mA
Thermal noise factor	F	24	22 dB
AM to PM conversion	$k_p$	2,5	1,5 °/dB

**LIMITING VALUES** (Absolute maximum rating system)

Voltages are with respect to the cathode unless otherwise specified.

Focusing electrode voltage	$V_{g1}$	min.	0 V
		max.	50 V
Accelerator voltage	$V_{g2}$	max.	2700 V
Helix voltage	$V_x$	max.	3300 V
Collector to helix voltage	$V_{coll-x}$	max.	2500 V
Cathode current	$I_k$	max.	58 mA
Accelerator current	$I_{g2}$	max.	0,3 mA
Helix current	$I_x$	max.	3 mA
R.F. input level	$W_i$	max.	100 mW
Collector dissipation at $T_{amb} = 65\text{ °C}$	$W_{coll}$	max.	90 W
Power reflected from load (to avoid overheating of the helix)		max.	2 W
Cooler temperature at reference point	T	max.	150 °C

\* To be adjusted for indicated collector current.

## DESIGN AND OPERATING NOTES

### 1. Installation of the mount

Two main methods may be discerned:

- a. Fixing the mount relative to the microwave circuit by only connecting the waveguide tapers to the input and output sides of the circuit.
- b. Employing (a) and establishing additional support by fastening the mount to the rack with clamps. In this case it is recommended to use a short piece of flexible waveguide at the input and output sides to prevent excessive strain on the mount via the tapers, unless very careful alignment of the waveguides can be assured.

Possible forces on the waveguides must not produce a moment greater than 20 Nm at the flanges.

#### 1.1 Mount

The mount has no movable parts. If clamps are used (method b) the slightly larger dimensions of the cooler as compared to the main part of the mount must be considered.

#### 1.2 Magnetic shielding

The periodic permanent magnet is completely shielded. This implies that no additional measures need be taken to prevent the magnetic properties of the mount from being affected by external magnetic fields. The mount will not influence surrounding equipment which is susceptible to stray magnetic fields. Several mounts may be placed side by side without disturbing the focusing qualities. Isolators may be installed quite near to the mount.

#### *Warning*

*If any part of the shielding is removed, the magnetic properties of the mount may be disturbed irreversibly.*

### 2. Installation of the tube

Unlock the mount cap (see outline drawing) by turning it slightly counter-clockwise. The cap can then easily be removed, and the tube inserted by carefully pushing it in. The tube is provided with a mark on the accelerator terminal. For optimum performance the tube must be inserted with this mark in line with the centre line a) of the cable housing on the mount. (See Fig. 2). Finally put the cap on the mount again, and lock by turning it clockwise. These instructions also apply (in the reverse order) for taking the tube out of the mount.

### 3. Safety

The supply voltages are fed to the tube via the mount cap. When the cap is unlocked all voltages are removed from the tube. The two violet leads can be incorporated into an additional safety circuit which switches the voltages off at the power supply if the cap is unlocked. Thus the voltages can also be removed from the mount. The mount should always be earthed.

4. Power supply

An example of a supply circuit for 5, 10 and 15 W operation is given in Fig. 4.

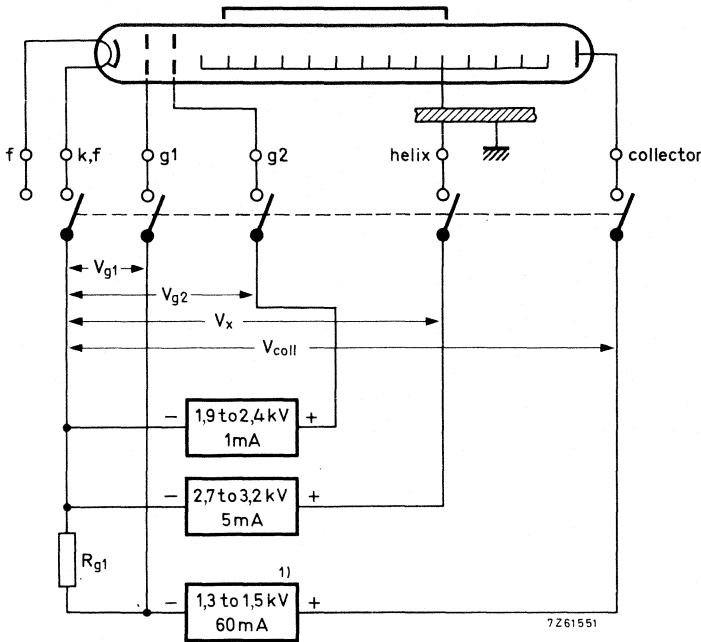

Fig. 4.

Design ranges for the power supply (electrode voltages with respect to cathode).

	min.	max.
Accelerator voltage	1900	2400 V
Accelerator current		0,3 mA
Helix voltage*	2700	3200 V
Helix current		3 mA

The collector voltage is set at a fixed voltage dependent on the output power level.

Output power level	$W_o$	5	10	15	$W_{sat}$ W
Collector voltage	$V_{coll}$	1300	1450	1500	1700 V
Collector current	$I_{coll}$	52,5	52,5	55,0	52,5/55,0 mA
Focusing electrode voltage	$V_{g1}$	-6	-6	-6	-6 V

\* At saturation the helix voltage may reach 3300 V.

## 5. Cooling

Tube and mount need no artificial means of cooling. Natural cooling of the collector has been made possible by depression of the collector potential with respect to the helix and by ensuring adequate heat transfer from the collector to the environment.

Under typical operating conditions and at an ambient temperature of not more than 65 °C, the cooler temperature at the reference point (see Fig. 2) is well below the limit, provided an aluminium heatsink of 300 x 300 x 6 mm is mounted on one of the cooler surfaces. The heatsink is best fixed with its centre coinciding with that of the cooler, and in a vertical position. The mount itself may have any position in the equipment.

Other heatsink configurations may be employed. It will then be necessary to check the temperatures reached at the reference point under extreme conditions e.g. 65 °C ambient temperature.

## 6. Application of voltages

### 6.1 *Switching-on procedure for new tubes*

- 6.1.1 Apply the heater voltage for the specified waiting time.
- 6.1.2 Apply the rated voltages to the collector, the helix, the accelerator (and in case of a separate supply to the focusing electrode) simultaneously (see Notes).
- 6.1.3 Adjust the accelerator voltage to obtain the collector current of 52,5 or 55,0 mA.
- 6.1.4 Apply the r.f. input signal, adjust the level to obtain the required output power while simultaneously adjusting the helix voltage for optimum gain.

### 6.2 *Readjustment during life*

During life the collector current may decrease. A readjustment of the accelerator voltage to obtain  $I_{coll} = 52,5$  (55,0) mA will then be necessary.

### 6.3 *Switching-off procedure*

All voltages should be switched off simultaneously. If this is not feasible, do as described under "Notes".

### 6.4 *Switching-on procedure after interruption of voltage (also see the Notes)*

- 6.4.1 Interruption of less than 40 s: Switch on all voltages simultaneously.
- 6.4.2 Interruption of more than 40 s but less than 1 week: Apply the heater voltage for min. 40 s, then apply all other voltages simultaneously.
- 6.4.3 Interruption of more than 1 week: Apply the heater voltage for the specified waiting time of 2 min. Apply all other voltages simultaneously.

## Notes

When the voltages cannot be switched simultaneously all the cathode current may flow to the accelerator or the helix. If this condition lasts for more than 10 ms, it may cause permanent damage to the tube. The remedy is to switch the accelerator voltage on after the other electrode voltages, or off before the other electrode voltages.



### 7. Input and output circuit and group delay

In order to avoid phase distortions due to long-line effect, the insertion of an isolator between tube and antenna, and another between tube and pre-stage is strongly recommended. The isolators should be positioned as close to the tube as possible.

If isolators with a VSWR of less than 1,05 are used at a short distance from the tube, the reflections result in a variation of the group delay of less than 0,2 nanoseconds over a band of 20 MHz.

It may be noted that the difference between the voltage reflection coefficients of the hot and the cold (i.e. with respectively without electron beam) tube is less than 0,2 for the input as well as the output side, measured at an output power level of 5 W or more.

### 8. Environmental conditions

Ambient temperature,

storage

T <sub>amb</sub>	min	-60 °C
	max.	+65 °C

operation

T <sub>amb</sub>	min.	-30 °C
	max.	+65 °C

Relative humidity

0 to 95 %

The tube and mount resist fungus attack.



7Z61540

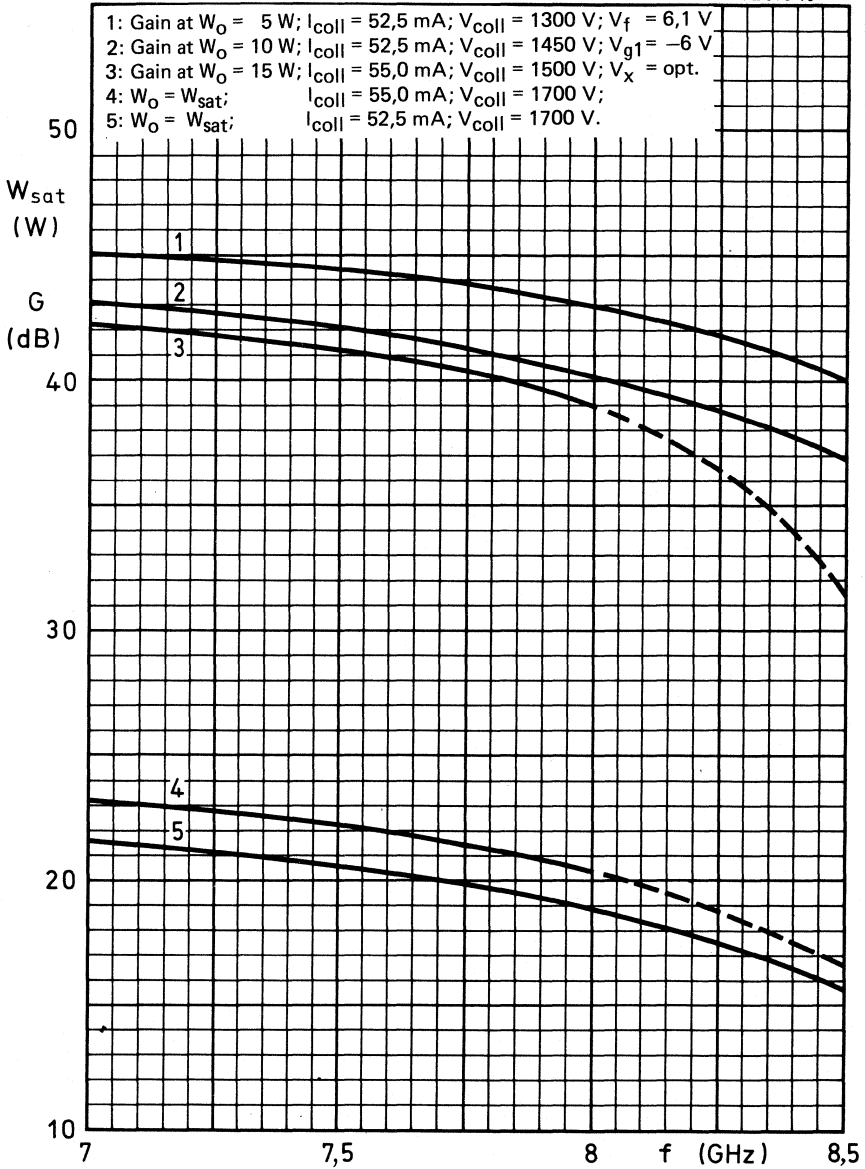

Fig. 5 Ratio of gain and saturation power to frequency.

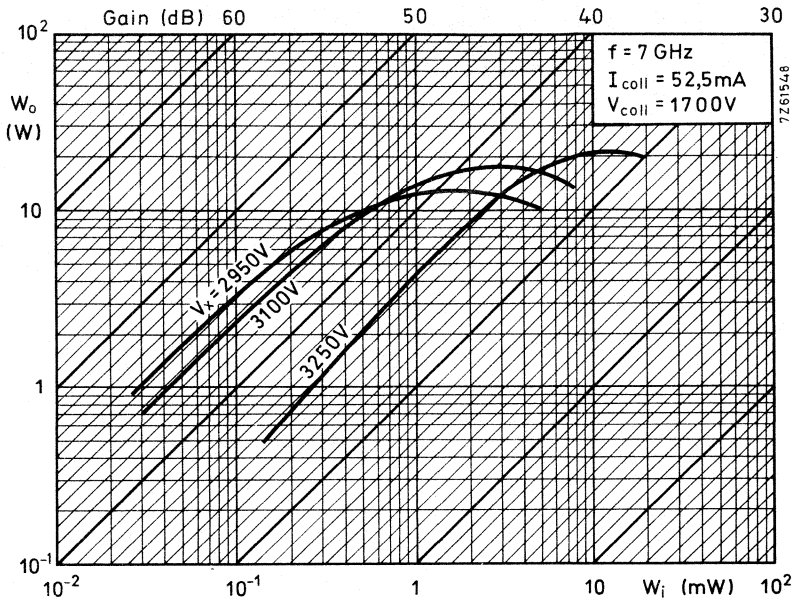

Fig. 6 Ratio of output power to input power.

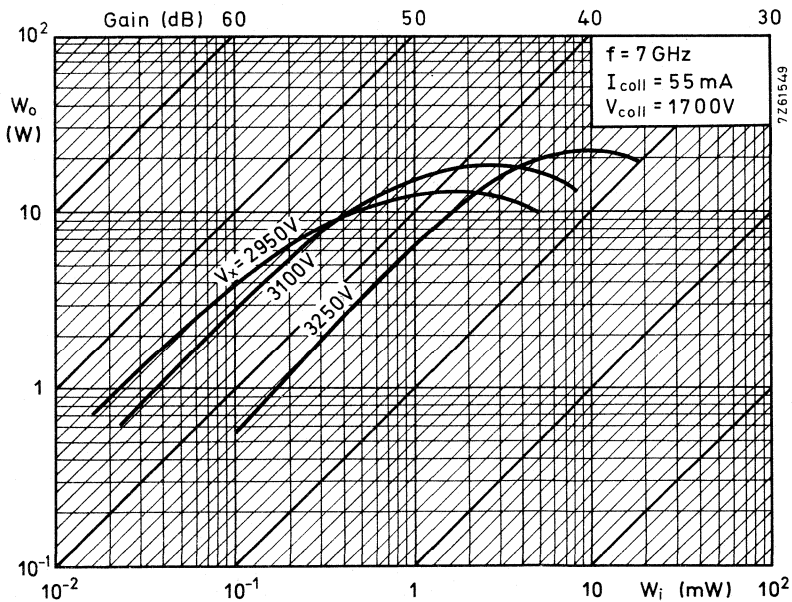

Fig. 7 Ratio of output power to input power.

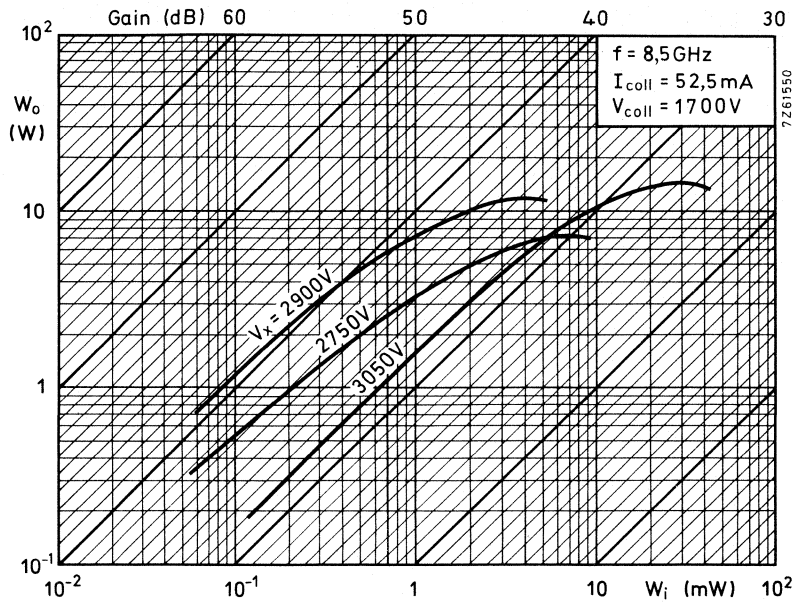
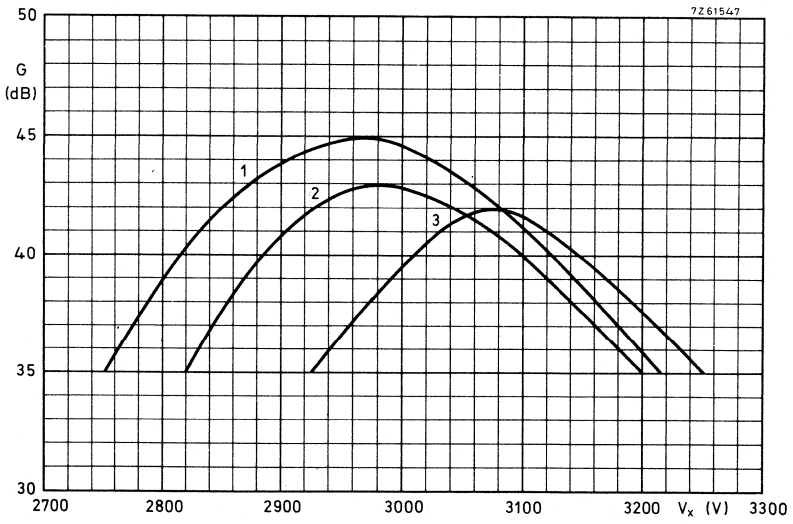
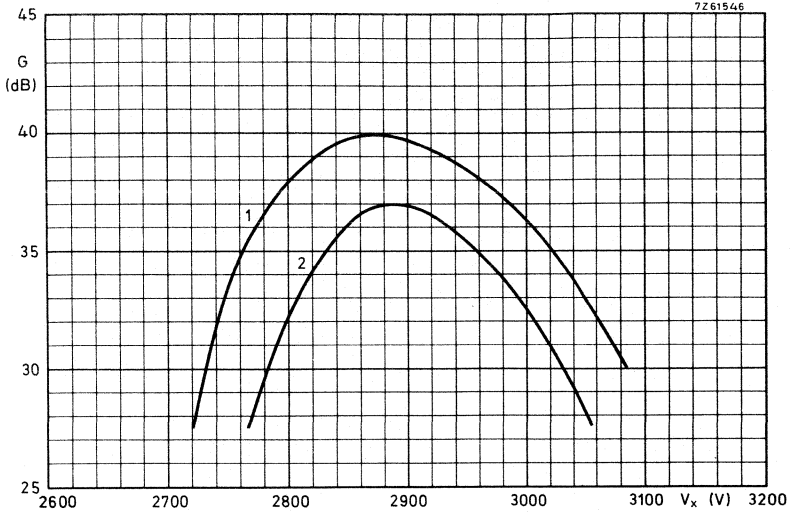

Fig. 8 Ratio of output power to input power.



- 1:  $W_o = 5\text{ W}$ ;  $V_{\text{coll}} = 1300\text{ V}$ ;  $I_{\text{coll}} = 52,5\text{ mA}$
- 2:  $W_o = 10\text{ W}$ ;  $V_{\text{coll}} = 1450\text{ V}$ ;  $I_{\text{coll}} = 52,5\text{ mA}$
- 3:  $W_o = 15\text{ W}$ ;  $V_{\text{coll}} = 1500\text{ V}$ ;  $I_{\text{coll}} = 55,0\text{ mA}$

Fig. 9 Ratio of gain to helix voltage;  $f = 7,0\text{ GHz}$ .



1:  $W_0 = 5 \text{ W}$ ;  $V_{\text{coll}} = 1300 \text{ V}$ ;  $I_{\text{coll}} = 52,5 \text{ mA}$   
 2:  $W_0 = 10 \text{ W}$ ;  $V_{\text{coll}} = 1450 \text{ V}$ ;  $I_{\text{coll}} = 52,5 \text{ mA}$

Fig. 10 Ratio of gain to helix voltage;  $f = 8,5 \text{ GHz}$ .

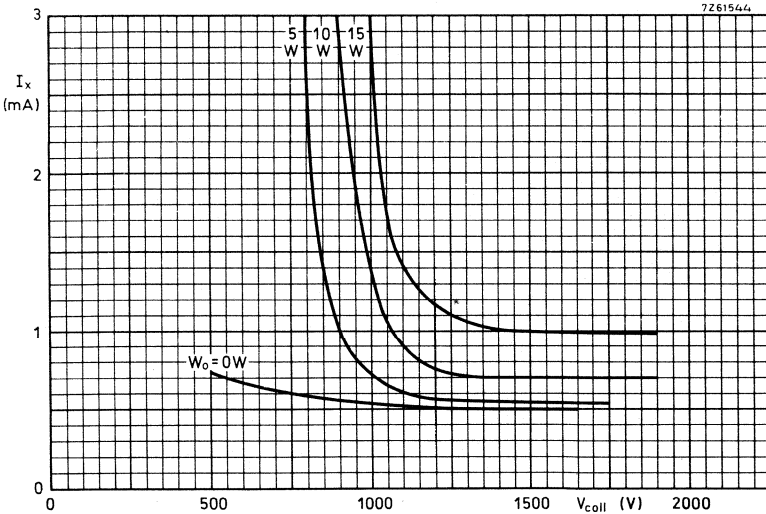

$f = 8 \text{ GHz}$   
 $V_x = \text{optimum}$

$I_{\text{coll}} = 55,0 \text{ mA}$	$I_{\text{coll}} = 52,5 \text{ mA}$
at $W_0 = 0 \text{ W}$	at $W_0 = 5 \text{ W}$
$W = 15 \text{ W}$	$W = 10 \text{ W}$

Fig. 11 Ratio of helix current to collector voltage.

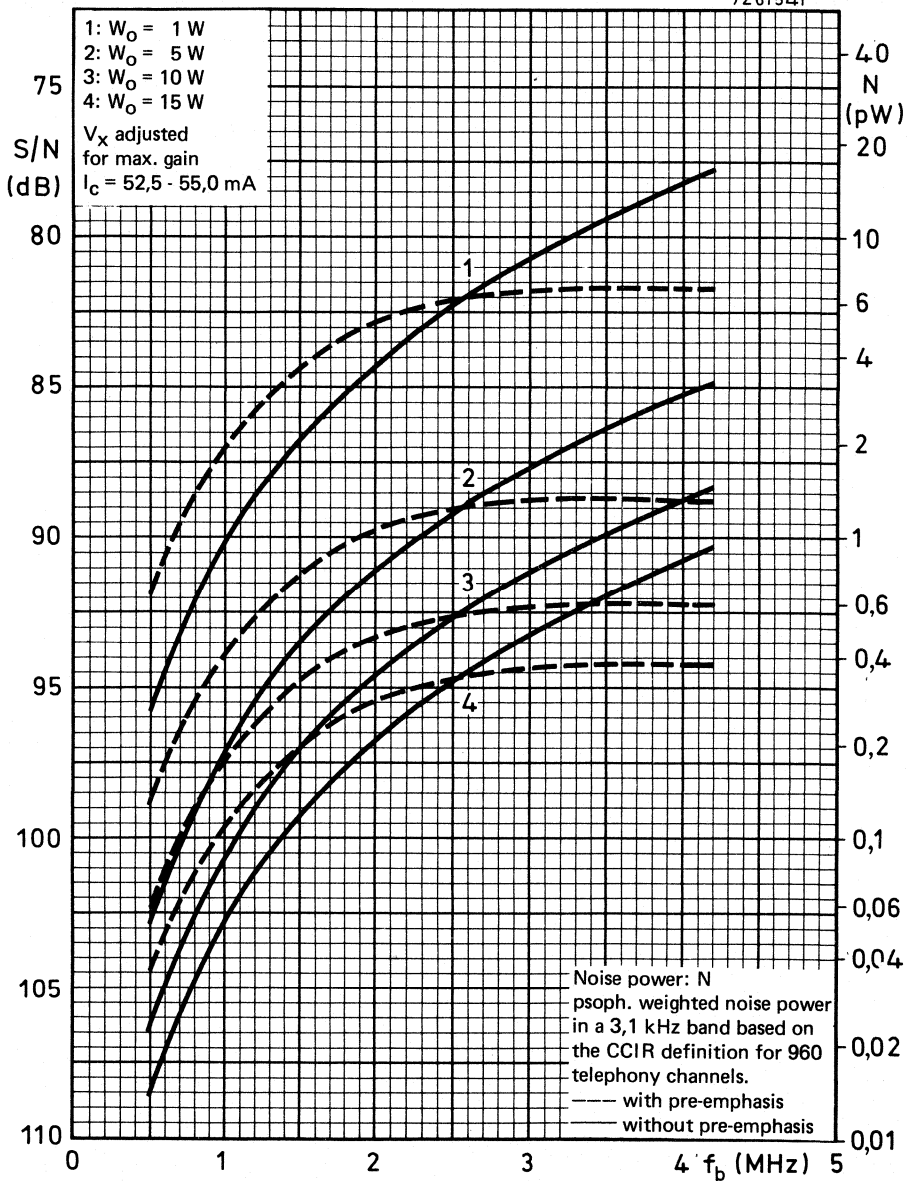

Fig. 12 Ratio of signal-to-noise ratio (FM) to baseband frequency;  $f = 7 \text{ GHz}$ .

7Z61542

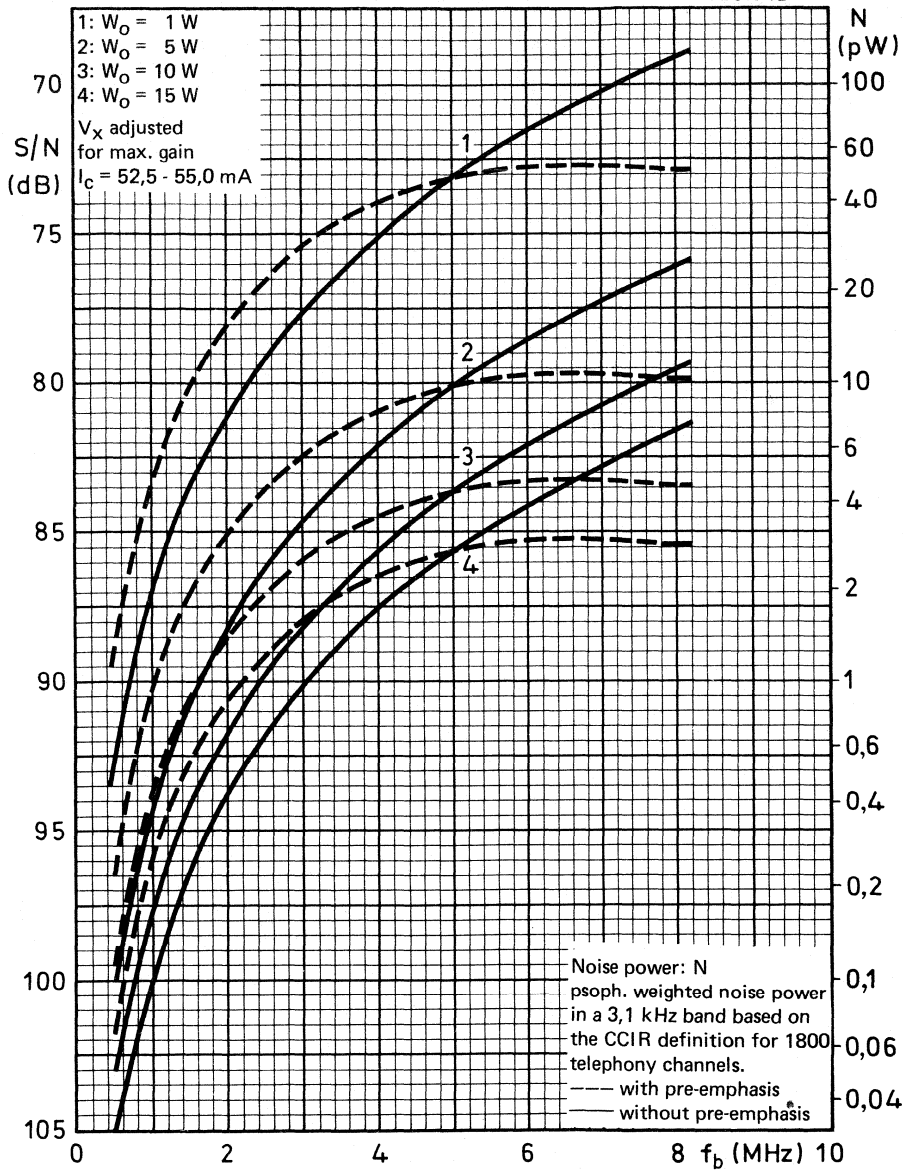

Fig. 13 Ratio of signal-to-noise ratio (FM) to baseband frequency;  $f = 7 \text{ GHz}$ .

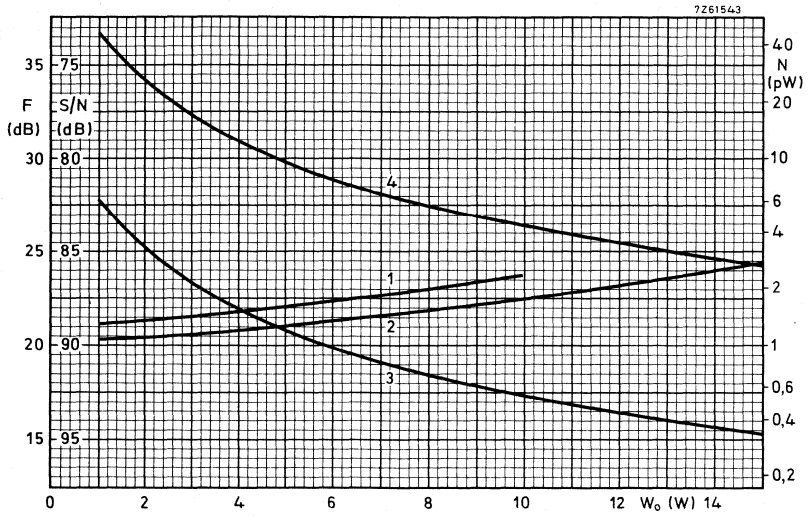

Fig. 14 Ratio of thermal noise (FM) to output power;  $f = 7$  GHz.

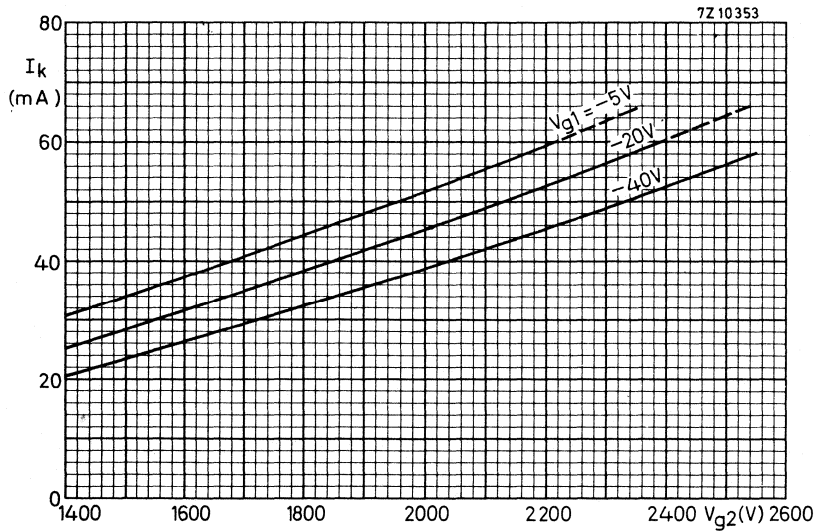

Fig. 15 Ratio of cathode current to accelerator voltage.



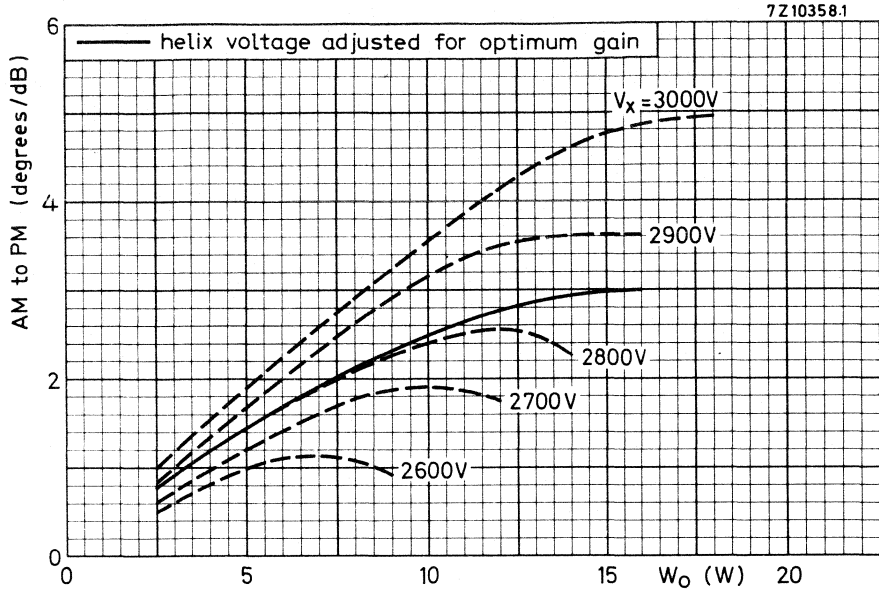

Fig. 16 Ratio of AM-to-PM conversion to output power;  $f = 7$  GHz.

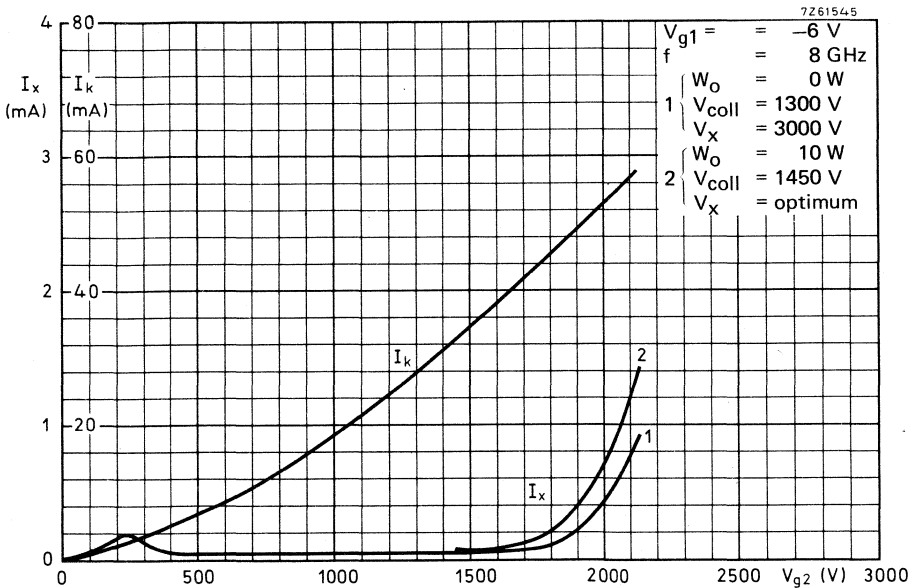

Fig. 17 Ratio of cathode current and helix current to accelerator voltage.



## TRAVELLING-WAVE TUBE

## QUICK REFERENCE DATA

Frequency range	f	4,4 to 5,0 GHz
Low level gain at 5,0 GHz	G >	36 dB
Saturated output power	$W_o$ >	6 W
Construction	unpackaged with uniform field permanent magnet focusing	

## DESCRIPTION

The wave propagating structure is of the helical type. The separate mount for the tube with r.f. conductors for coupling to the input and output waveguides contains a permanent magnet of the uniform field type, which is completely shielded by means of the surrounding box.

The tube is designed for plug-in match in the waveguide circuit. This gives the advantage that, after changing tubes, no tuning will be necessary, nor will the voltages on the tube have to be re-established, apart from the starting procedure. Only a slight adjustment of the tube in the magnetic field will be required.

## HEATING: indirect; dispenser type cathode

Heater voltage	$V_f$	6,3 V
Heater current	$I_f$	800 mA
Waiting time	$t_w$ min.	5 min

## GENERAL CHARACTERISTICS

Magnetic field strength	H	48 kA/m
Cold transmission loss (f = 4,4 to 5,0 GHz)	>	55 dB
Saturated output power ( $I_{coll} = 50$ mA)	$W_o$ >	6 W
Frequency	f	5,0 GHz
Helix voltage	$V_x$	optimal
Collector current	$I_{coll}$	50 mA
Output power	$W_o$	100 mW
Low level gain	G >	36 dB

**MECHANICAL DATA**

Net mass 0,5 kg  
 Net mass of mount 30 kg  
 Input and output waveguides RG-49/U

Connections of the plug of the mount

- 1 } Helix (x)
- 2 } Helix (x)
- 3 -
- 4 Collector (coll)
- 5 Accelerator (acc)
- 6 Heater (f)
- 7 Heater and cathode (f, k)

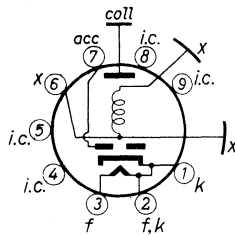

Tube base (Noval)

Dimensions in mm

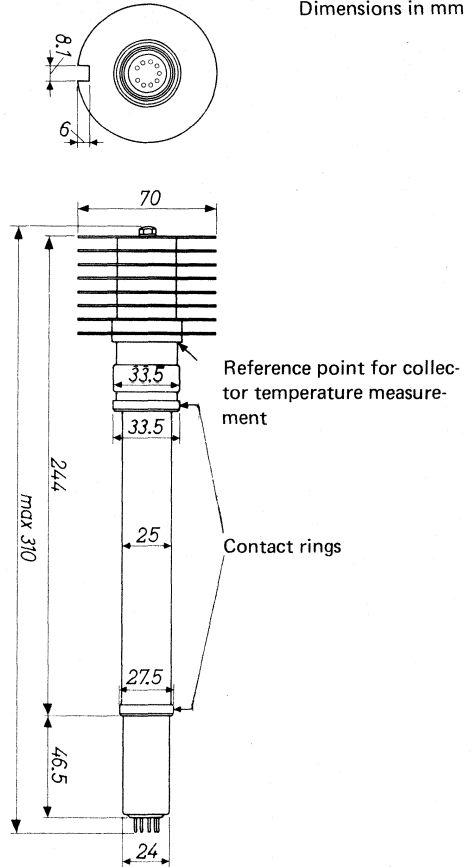
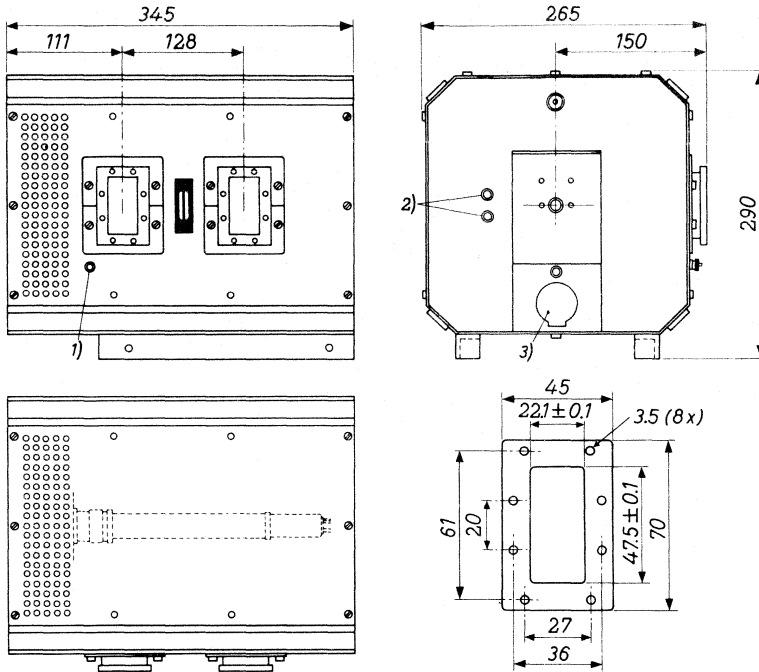

Fig. 1.

Mounting position: arbitrary, see "Cooling".



- (1) Earth connection.
- (2) Alignment screws.
- (3) Connector to power supply.

Fig. 2 Mount 55310

**WARNING**

*Do not apply voltages to the tube when the door is open.  
Do not remove any part of the shielding box, nor introduce ferro-magnetic materials into the mount.*

**NOTE**

A socket wrench for the alignment screws is fixed near the fastener on the door.

**LIMITING VALUES** (Absolute maximum rating system)

Voltages with respect to cathode.

Heater voltage	$V_f$	6,3	$V \pm 2\%$
Cathode current	$I_k$	max. 55	mA
Accelerator voltage	$V_{acc}$	max. 1500	V
Accelerator to helix voltage	$V_{acc-x}$	max. 500	V
Accelerator current	$I_{acc}$	max. 0,35	mA
Helix voltage	$V_x$	max. 1500	V (note 1)
Helix current	$I_x$	max. 4	mA
Collector voltage	$V_{coll}$	max. 1500	V
Collector dissipation	$W_{coll}$	max. 70	W
Collector temperature	$T_{coll}$	max. 175	$^{\circ}C$ (note 2)

**OPERATING CHARACTERISTICS** as power amplifier

Voltages with respect to helix.

Frequency	$f$	4,4 to 5,0	GHz
Cathode voltage	$V_k$	-1100	V
Accelerator voltage	$V_{acc}$	-30	V
Accelerator current	$I_{acc}$	< 0,35	mA
Helix current	$I_x$	< 3	mA
Collector voltage	$V_{coll}$	+50	V
Collector current	$I_{coll}$	47 to 53	mA
Power gain at $f = 5,0$ GHz			
at $W_o = 100$ mW	$G$	> 34	dB
at $W_o = 2,5$ W	$G$	> 32	dB
Voltage standing-wave ratio		< 1,5	(note 3)
Noise figure	$F$	< 30	dB

**NOTES**

1. The helix is galvanically connected to the mount.
2. For reference point of the collector temperature see Fig. 1.
3. For input and output. Measured cold, i.e. with beam switched off. For further particulars see paragraph "Transmission line".

### Cooling

The tube is convection cooled by natural air circulation. Under normal operating conditions and at  $T_{amb} < 55\text{ }^{\circ}\text{C}$  no forced air cooling is required to keep the collector temperature below the maximum permissible value of  $175\text{ }^{\circ}\text{C}$ , provided the tube is mounted horizontally and no obstructions are offered for the air circulation through the ventilation holes in the mount. For less favourable conditions a slight additional air flow will be necessary.

### Shielding

Nowhere along the box surface a magnetic field strength of  $160\text{ kA/m}$  close to the shielding plates extended over a cross-sectional area of  $30\text{ cm}^2$  and directed perpendicular to the box surface, causes a change, worth mentioning, in the focus quality. Several mounts may be placed on top of or next to each other, without mutual disturbance of focusing qualities.

The stray field of the mount, measured at a distance of  $1\text{ cm}$  from the box, is in general less than  $800\text{ A/m}$ . At a few spots, e.g. near the ventilation holes and the alignment screws this value is exceeded with maximum  $1,6\text{ kA/m}$ , but then the  $800\text{ A/m}$  value is still reached within a distance of  $4\text{ cm}$  from the box.

### Transmission line

To obtain the full benefit of the broadband characteristics of the tube, the insertion of an isolator between the tube and the pre-stage and between the tube and the antenna is strongly recommended. The isolators should be positioned as close as possible to the tube. By these provisions phase distortion by long line effects is avoided.

The difference between the reflection coefficients at input and output sides of the cold tube (i.e. without beam) and the warm tube is less than  $0,2$ . Provided an isolator with a VSWR of less than  $1,05$  is placed at a short distance ( $10$  to  $20\text{ cm}$ ) at either side of the tube, the reflections result in a variation of group delay of less than  $0,1\text{ ns}$  over a band of  $20\text{ MHz}$ .

### Operating instructions

The mount is provided with an alignment device for the proper positioning of the tube with respect to the magnetic field in the mount. For alignment screws see drawing of the mount.

As the helix current depends on the position of the tube with respect to the magnetic field, special attention must be given to the proper alignment of the tube during steps c and d of the starting procedure given below. To prevent tube damage it is essential to observe the  $4\text{ mA}$  maximum limit on the helix current.

### 1. Starting procedure

- 1.1 Remove the plug, loosen the fastener and open the door.
- 1.2 Insert the tube into the mount as shown in the drawing of the mount (take care, the tube is subject to magnetic forces). If the tube is obstructed by some parts of the mount, a small correction in the position of the tube will be sufficient to avoid the obstacles.
- 1.3 Close the door, lock the fastener and put on the plug.
- 1.4 Switch on the supply voltages in the following sequence (the voltages mentioned below are with respect to the helix, which is normally at ground potential):
  - a. Apply the rated heater voltage for at least 5 minutes.
  - b. Apply +50 V to the collector and -30 V to the accelerator. These voltages may be applied simultaneously.
  - c. Apply the cathode voltage gradually, adjusting the alignment of the tube in order not to exceed 4 mA helix current.
  - d. Apply the h.f. signal to the input of the tube and adjust the alignment of the tube until the helix current reaches a minimum.

### 2. Switching procedure after interruption of voltages

- 2.1 *Interruption less than 1 s.* All voltages can be applied simultaneously. The output will reach 95% of the stable end value within 0,2 s after the application of the voltages.
- 2.2 *Interruption 1 s or more.* The voltages must be applied in the following sequence:
  - a. Apply the rated heater voltage for at least 40 s.
  - b. Apply +50 V to the collector and -30 V to the accelerator. These voltages may be applied simultaneously.
  - c. Apply the rated cathode voltage. Voltages mentioned under b and c can be applied simultaneously.

The h.f. voltage can be applied at any time.

The output will reach 95% of the stable end value within 60 s after the application of the heater voltage.

### Note

The procedure described under 2.2 can be followed without any risk of disturbing the properties of the tube. It should be noted, however, that normally about 5 minutes cathode heating time is required to obtain completely stable operation of the tube.

### 3. Switching off procedure

- 3.1
  - a. Switch off all voltages simultaneously.
  - b. Remove plug, open the door and pull out the tube.
- 3.2
  - a. Bring accelerator voltage to helix potential.
  - b. Switch off the cathode voltage.
  - c. Switch off the accelerator, collector and heater voltages.
  - d. Remove plug, open the door and pull out the tube.

The methods 3.1 and 3.2 are optional.



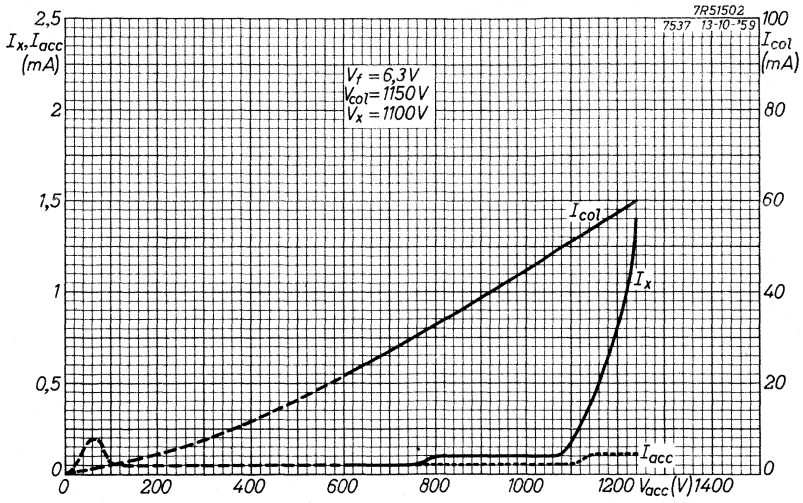

Fig. 3.

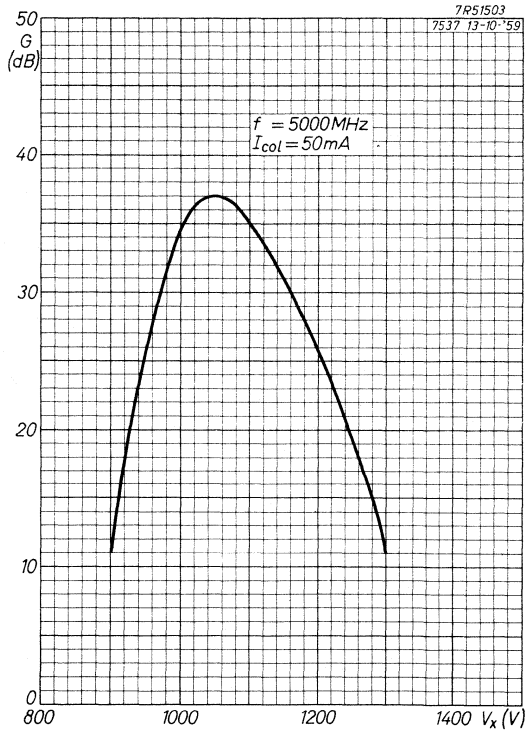

Fig. 4.



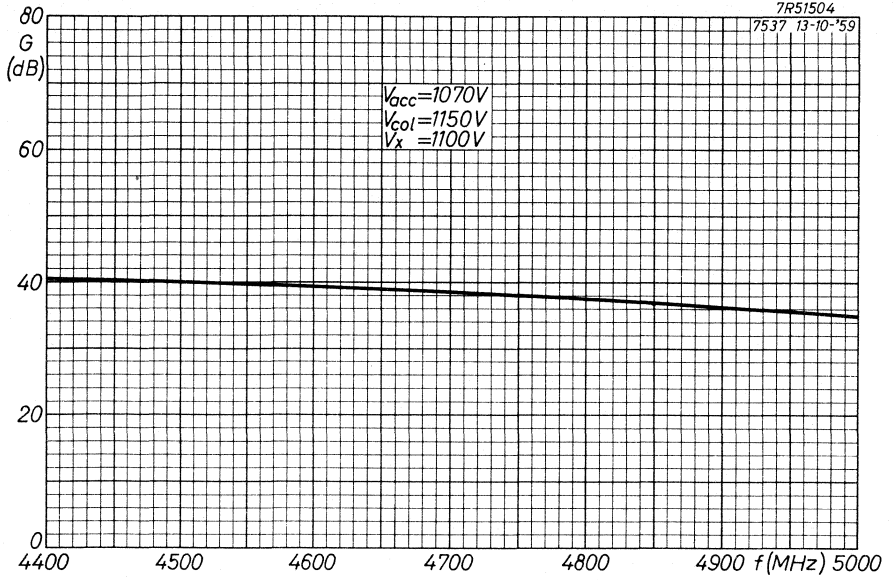

Fig. 5.

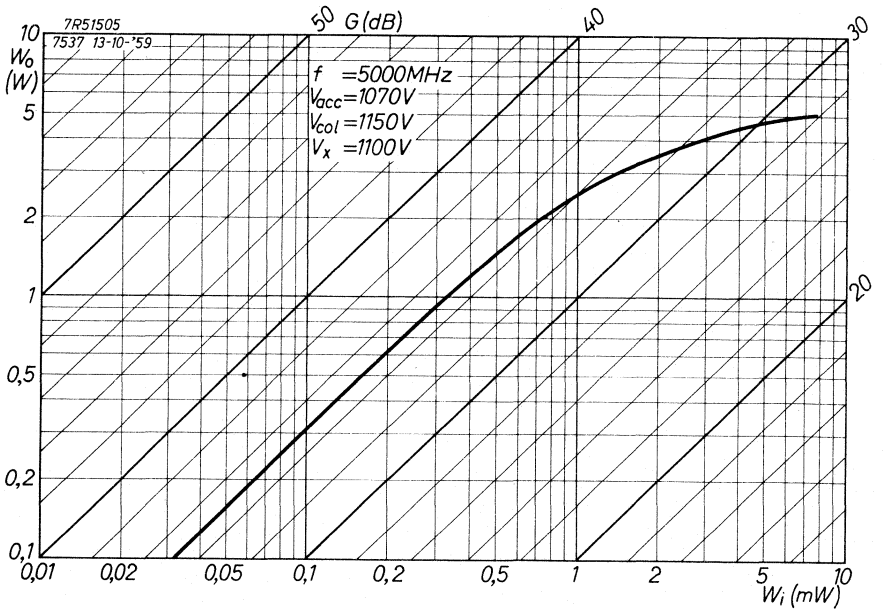

Fig. 6.

## TRAVELLING-WAVE TUBE

## QUICK REFERENCE DATA

Frequency range	f	3,8 to 4,2 GHz
Low level gain at 4,2 GHz	G	> 39 dB
Saturated output power	$W_o$	> 8 W
Construction	unpackaged with uniform field permanent magnet focusing	

## DESCRIPTION

The wave propagating structure is of the helical type. The separate mount for the tube with r.f. conductors for coupling to the input and output waveguides contains a permanent magnet of the uniform field type, which is completely shielded by means of the surrounding box.

The tube is designed for plug-in match in the waveguide circuit. This gives the advantage that, after changing tubes, no tuning will be necessary, nor will the voltages on the tube have to be re-established, apart from the starting procedure. Only a slight adjustment of the tube in the magnetic field will be required.

**HEATING:** indirect; dispenser type cathode.

Heater voltage	$V_f$	6,3 V
Heater current	$I_f$	800 mA
Waiting time	$t_w$	min. 5 min

## GENERAL CHARACTERISTICS

Magnetic field strength	H	48 kA/m
Cold transmission loss (f = 3,8 to 4,2 GHz)		> 60 dB
Saturated output power ( $I_{coll} = 50$ mA)	$W_o$	> 8 W
Frequency	f	4,2 GHz
Helix voltage	$V_x$	optimal
Collector current	$I_{coll}$	50 mA
Output power	$W_o$	100 mW
Low level gain	G	> 39 dB

**MECHANICAL DATA**

Net mass 0,5 kg

Net mass of mount 30 kg

Input and output waveguides WR229

Connections of the plug of the mount

- 1 } Helix (x)
- 2 } Helix (x)
- 3 -
- 4 Collector (coll)
- 5 Accelerator (acc.)
- 6 Heater (f)
- 7 Heater and cathode (f, k)

Dimensions in mm

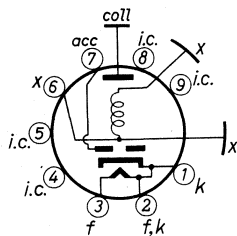
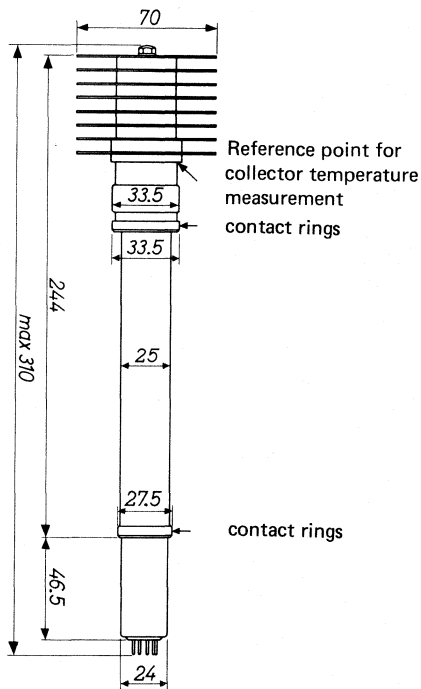
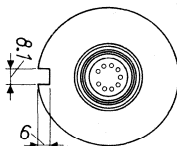

Tube base (Noval)

Fig. 1.

Mounting position: arbitrary, see "Cooling".

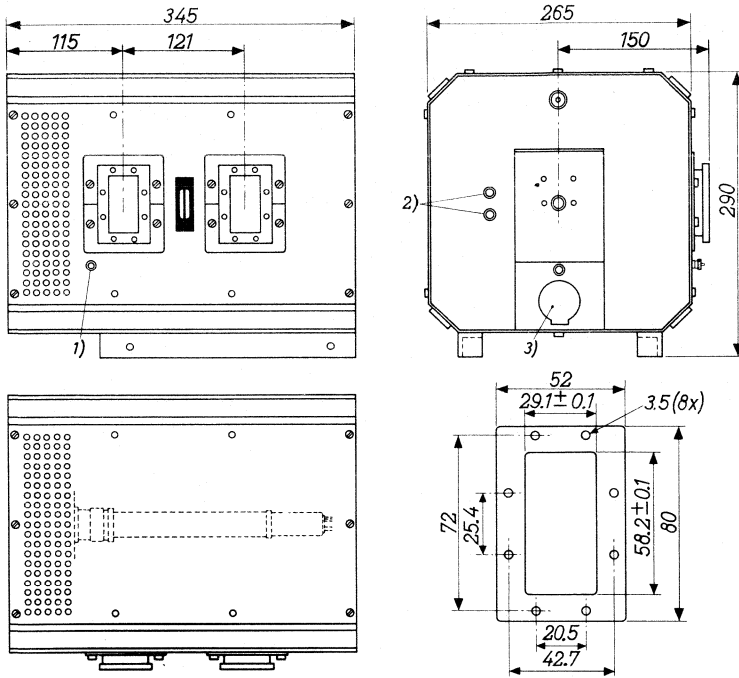

- (1) Earth connection.
- (2) Alignment screws.
- (3) Connector to power supply.

Fig. 2 Mount 55309.

**WARNING**

*Do not apply voltages to the tube when the door is open.  
Do not remove any part of the shielding box, nor introduce ferro-magnetic materials into the mount.*

**NOTE**

A socket wrench for the alignment screws is fixed near the fastener on the door.

**LIMITING VALUES** (Absolute maximum rating system)

Voltages with respect to cathode.

Heater voltage	$V_f$		$6,3 \text{ V} \pm 2 \%$
Cathode current	$I_k$	max.	55 mA
Accelerator voltage	$V_{acc}$	max.	1500 V
Accelerator to helix voltage	$V_{acc-x}$	max.	500 V
Accelerator current	$I_{acc}$	max.	0,35 mA
Helix voltage	$V_x$	max.	1500 V (note 1)
Helix current	$I_x$	max.	4 mA
Collector voltage	$V_{coll}$	max.	1500 V
Collector dissipation	$W_{coll}$	max.	70 W
Collector temperature	$T_{coll}$	max.	175 °C (note 2)

**OPERATING CHARACTERISTICS** as power amplifier

Voltages with respect to helix

Frequency	$f$		3,8 to 4,2 GHz
Cathode voltage	$V_k$		-1100 V
Accelerator voltage	$V_{acc}$		-30 V
Accelerator current	$I_{acc}$	<	0,35 mA
Helix current	$I_x$	<	3 mA
Collector voltage	$V_{coll}$		+50 V
Collector current	$I_{coll}$		47 to 53 mA
Power gain at $f = 4,2 \text{ GHz}$ at $W_o = 100 \text{ mW}$	$G$	>	37 dB
at $W_o = 3,0 \text{ W}$	$G$	>	35 dB
Voltage standing wave ratio		<	1,5 (note 3)
Noise figure	$F$	<	30 dB

**Notes**

1. The helix is galvanically connected to the mount.
2. For reference point of the collector temperature see Fig. 1.
3. For input and output. Measured cold, i.e. with beam switched off. For further particulars see paragraph "Transmission line".

### Cooling

The tube is convection cooled by natural air circulation. Under normal operating conditions and at  $T_{amb} < 55\text{ }^{\circ}\text{C}$  no forced air cooling is required to keep the collector temperature below the maximum permissible value of  $175\text{ }^{\circ}\text{C}$ , provided the tube is mounted horizontally and no obstructions are offered for the air circulation through the ventilation holes in the mount. For less favourable conditions a slight additional air flow will be necessary.

### Shielding

Nowhere along the box surface a magnetic field strength of  $160\text{ kA/m}$  close to the shielding plates extended over a cross sectional area of  $30\text{ cm}^2$  and directed perpendicular to the box surface, causes a change, worth mentioning, in the focus quality. Several mounts may be placed on top of or next to each other, without mutual disturbance of focusing qualities.

The stray field of the mount, measured at a distance of  $1\text{ cm}$  from the box, is in general less than  $800\text{ A/m}$ . At a few spots, e.g. near the ventilation holes and the alignment screws this value is exceeded with maximum  $1,6\text{ kA/m}$ , but then the  $800\text{ A/m}$  value is still reached within a distance of  $4\text{ cm}$  from the box.

### Transmission line

To obtain the full benefit of the broadband characteristics of the tube, the insertion of an isolator between the tube and the pre-stage and between the tube and the antenna is strongly recommended. The isolators should be positioned as close as possible to the tube. By these provisions phase distortion by long line effects is avoided.

The difference between the reflection coefficients at input and output sides of the cold tube (i.e. without beam) and the warm tube is less than  $0,2$ . Provided an isolator with a VSWR of less than  $1,05$  is placed at a short distance ( $10$  to  $20\text{ cm}$ ) at either side of the tube, the reflections result in a variation of group delay of less than  $0,1\text{ ns}$  over a band of  $20\text{ MHz}$ .

### Operating instructions

The mount is provided with an alignment device for the proper positioning of the tube with respect to the magnetic field in the mount. For alignment screws see drawing of the mount.

As the helix current depends on the position of the tube with respect to the magnetic field, special attention must be given to the proper alignment of the tube during steps c and d of the starting procedure given below. To prevent tube damage it is essential to observe the  $4\text{ mA}$  maximum limit on the helix current.

### 1. Starting procedure

- 1.1 Remove the plug, loosen the fastener and open the door.
- 1.2 Insert the tube into the mount as shown in the drawing of the mount (take care, the tube is subject to magnetic forces). If the tube is obstructed by some parts of the mount, a small correction in the position of the tube will be sufficient to avoid the obstacles.
- 1.3 Close the door, lock the fastener and put on the plug.
- 1.4 Switch on the supply voltages in the following sequence (the voltages mentioned below are with respect to the helix, which is normally at ground potential):
  - a. Apply the rated heater voltage for at least 5 minutes.
  - b. Apply +50 V to the collector and -30 V to the accelerator. These voltages may be applied simultaneously.
  - c. Apply the cathode voltage gradually, adjusting the alignment of the tube in order not to exceed 4 mA helix current.
  - d. Apply the h.f. signal to the input of the tube and adjust the alignment of the tube until the helix current reaches a minimum.

### 2. Switching procedure after interruption of voltages

- 2.1 *Interruption less than 1 s.* All voltages can be applied simultaneously. The output will reach 95% of the stable end value within 0,2 s after the application of the voltages.
- 2.2 *Interruption 1 s or more.* The voltages must be applied in the following sequence:
  - a. Apply the rated heater voltage for at least 40 s.
  - b. Apply +50 V to the collector and -30 V to the accelerator. These voltages may be applied simultaneously.
  - c. Apply the rated cathode voltage. Voltages mentioned under b and c can be applied simultaneously.

The h.f. voltage can be applied at any time.

The output will reach 95% of the stable end value within 60 s after the application of the heater voltage.

### Note

The procedure described under 2.2 can be followed without any risk of disturbing the properties of the tube. It should be noted, however, that normally about 5 minutes cathode heating time is required to obtain completely stable operation of the tube.

### 3. Switching off procedure

- 3.1
  - a. Switch off all voltages simultaneously.
  - b. Remove plug, open the door and pull out the tube.
- 3.2
  - a. Bring accelerator voltage to helix potential.
  - b. Switch off the cathode voltage.
  - c. Switch off the accelerator, collector and heater voltages.
  - d. Remove plug, open the door and pull out the tube.

The methods 3.1 and 3.2 are optional.



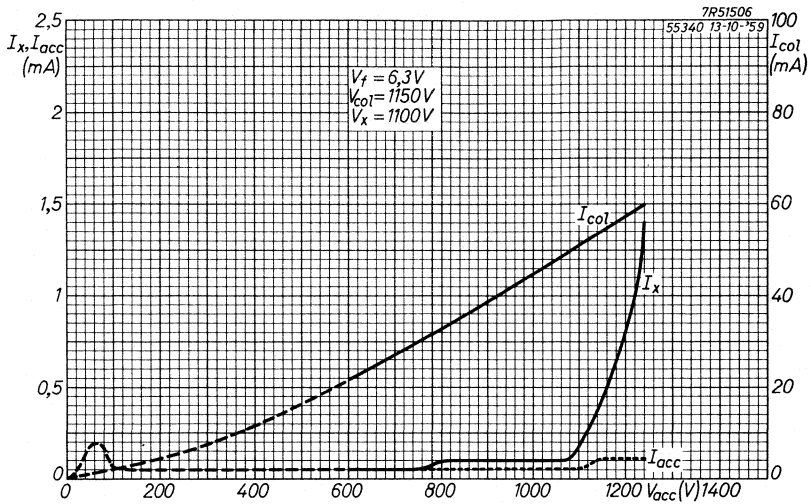

Fig. 3.

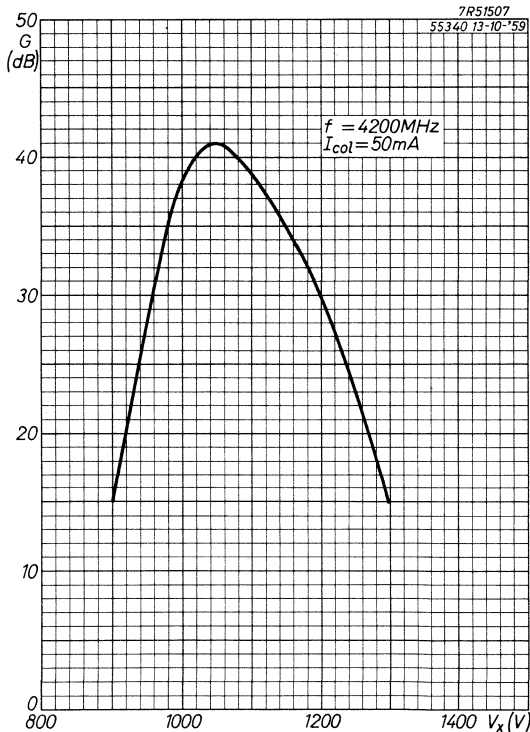

Fig. 4.

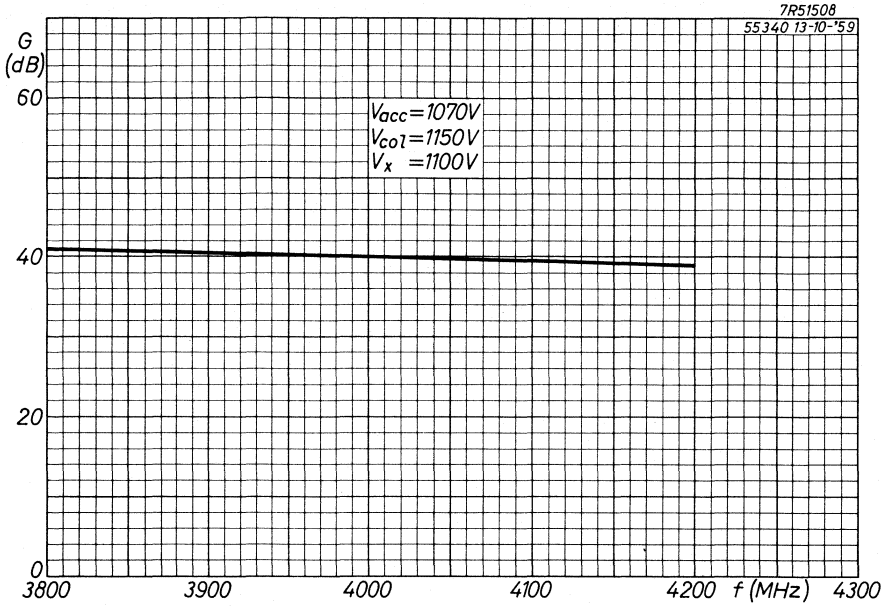

Fig. 5.

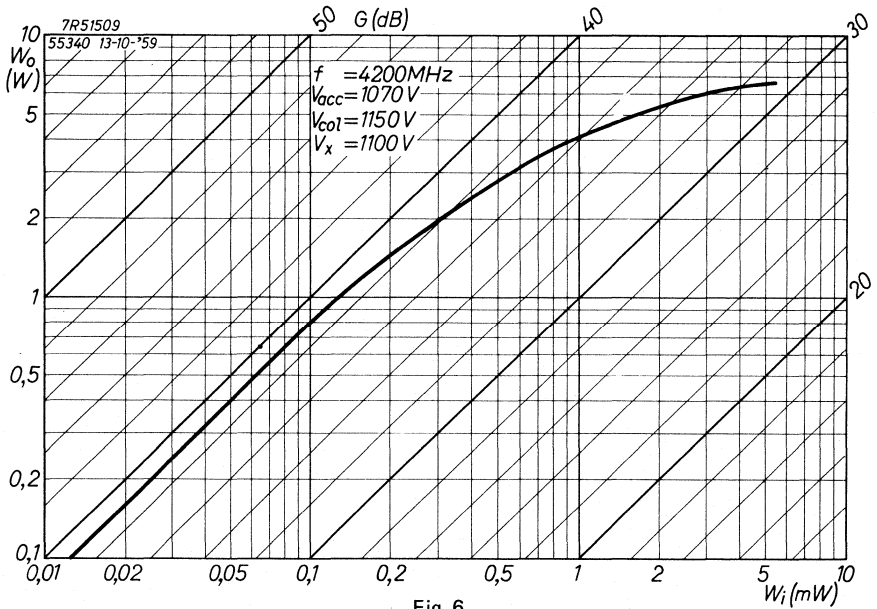

Fig. 6.

DIODES

E







## MEASURING DIODE

## QUICK REFERENCE DATA

Frequency	f		1000	MHz
Peak inverse voltage	$V_{d\text{ inv p}}$	max.	1000	V

HEATING: indirect by a.c. or d.c.; series or parallel supply

Heater voltage	$V_f$		6,3	V
Heater current	$I_f$		300	mA

## CAPACITANCE

Anode to cathode	$C_d$	max.	0,5	pF
------------------	-------	------	-----	----

## TYPICAL CHARACTERISTICS

Diode current	$I_d$		0,5	mA
Diode voltage	$V_d$	max.	3	V

## LIMITING VALUES (Absolute maximum rating system)

Peak inverse voltage	$V_{d\text{ inv p}}$	max.	1000	V
at $f < 100$ MHz				
at $f > 100$ MHz	$V_{d\text{ inv p}}$	max.	$\frac{100}{f} \times 1000$	V*
Cathode current, $V_f$ from 5,6 to 7,0 V	$I_k$	max.	0,3	mA
Peak cathode current, $V_f$ from 5,6 to 7,0 V	$I_{kp}$	max.	5	mA**
Voltage between heater and cathode	$V_{kf}$	max.	50	V
External resistance between heater and cathode	$R_{kf}$	max.	20	k $\Omega$
Heater voltage	$V_f$	max.	7,0	V
		min.	5,6	V

\* f in MHz.

\*\* For frequencies  $< 100$  Hz:  $I_{kp}$  max.  $0,3 + 0,047 f$  mA (f in Hz).

MECHANICAL DATA

Dimensions in mm

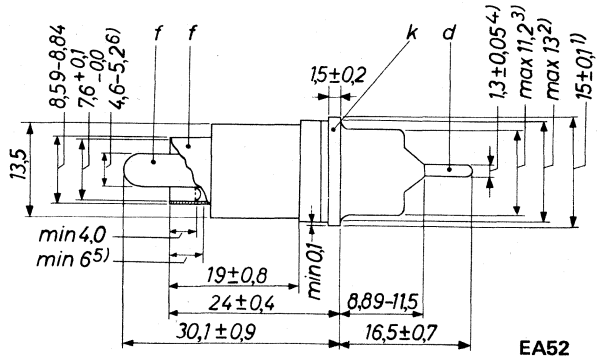
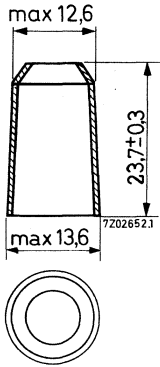

EA52

Protective cap for EA52

For protection during transport the EA52 is fitted with a plastic cap which should preferably be removed when the tube is mounted into position. If the cap is not removed, make sure that its temperature never exceeds 100 °C.

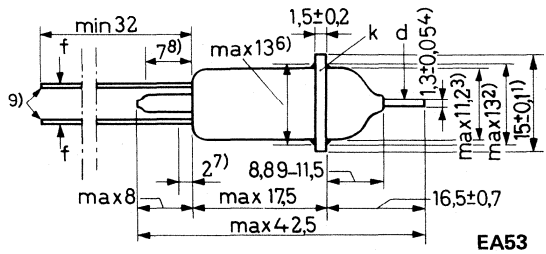

EA53

Fig. 1.

Notes

- (1) In order to avoid strain, the connection to the cathode disc should be sufficiently flexible.
- (2) Maximum diameter of the glass seal.
- (3) Eccentricity with respect to the cathode disc max. 0,35 mm.
- (4) Eccentricity with respect to the cathode disc max. 0,25 mm.
- (5) This dimension defines the length of the cylindrical section.
- (6) The max. dimension includes the eccentricity.
- (7) This part of the leads should not be bent.
- (8) This part of the leads should not be soldered.
- (9) Gold plated leads, 0,4 mm diameter.

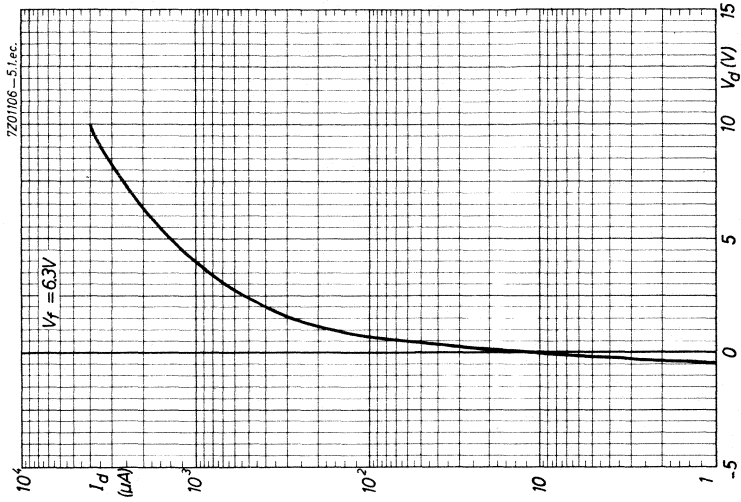

Fig. 2.

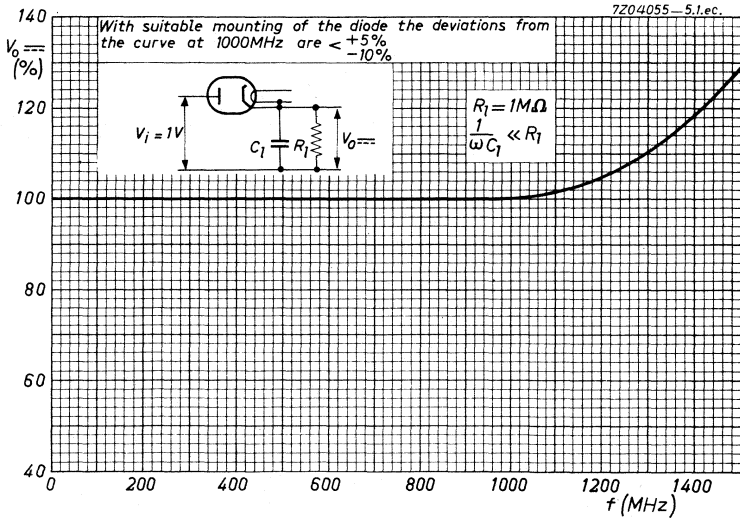

Fig. 3.

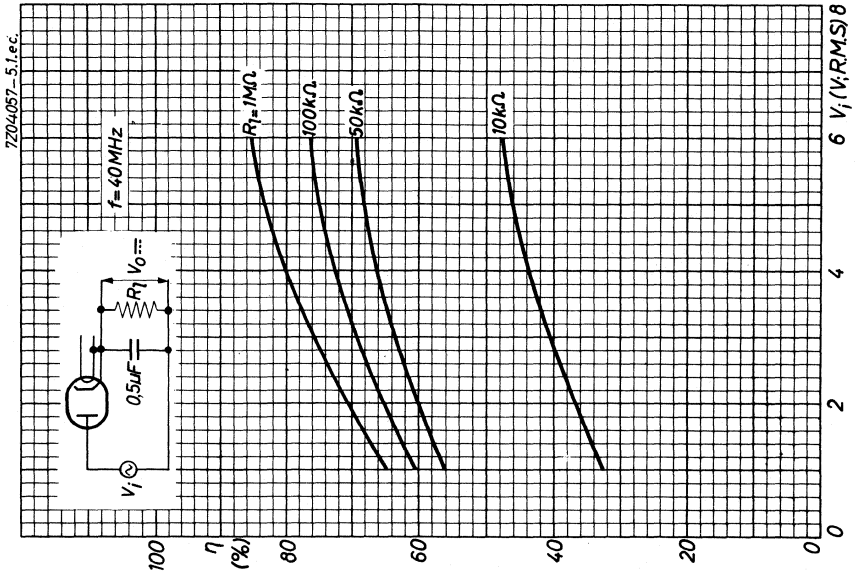

Fig. 5.

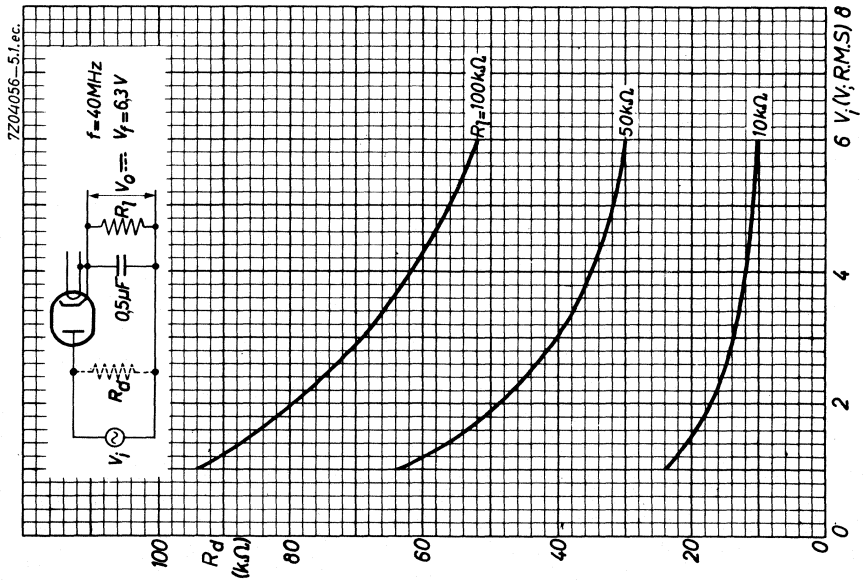

Fig. 4.



## NOISE DIODE

Rare gas-filled noise diode for use in waveguide systems in the 3 cm waveband.

## QUICK REFERENCE DATA

Noise level above 290 K	F	18,75 dB
Ignition voltage	$V_{ign}$ min.	6000 V
Anode current	$I_a$ max.	150 mA

**HEATING:** direct, parallel supply

Filament voltage	$V_f$	2 V $\pm$ 10%
Filament current	$I_f$	2 A
Heating time	$t_w$ min.	15 s

## TYPICAL CHARACTERISTICS

Anode voltage	$V_a$	165 V
Anode current	$I_a$	125 mA
Noise temperature	$T_F$	21 700 K $\pm$ 5%
Noise level above 290 K*	F	18,75 $\pm$ 0,2 dB
Ignition voltage	$V_{ign}$ min.	6000 V

**LIMITING VALUES** (Absolute maximum rating system)

Anode current	$I_a$ max.	150 mA
	min.	50 mA
Ambient temperature	$T_{amb}$	-55 to +75 °C

## NOTES

It is recommended that the noise diode and the microwave part of the mount are not touching (minimum diameter of pipe 7,5 mm).

The VSWR in the test mount with the noise diode in operation should not be more than 1,1.

\* Change in noise level over 200 hours of operation is negligible.

MECHANICAL DATA

Dimensions in mm

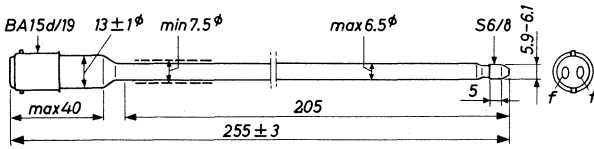

Fig. 1.

MOUNTING POSITION: Cathode at receiver side

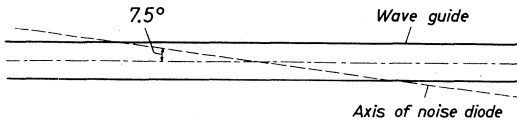

Fig. 2.

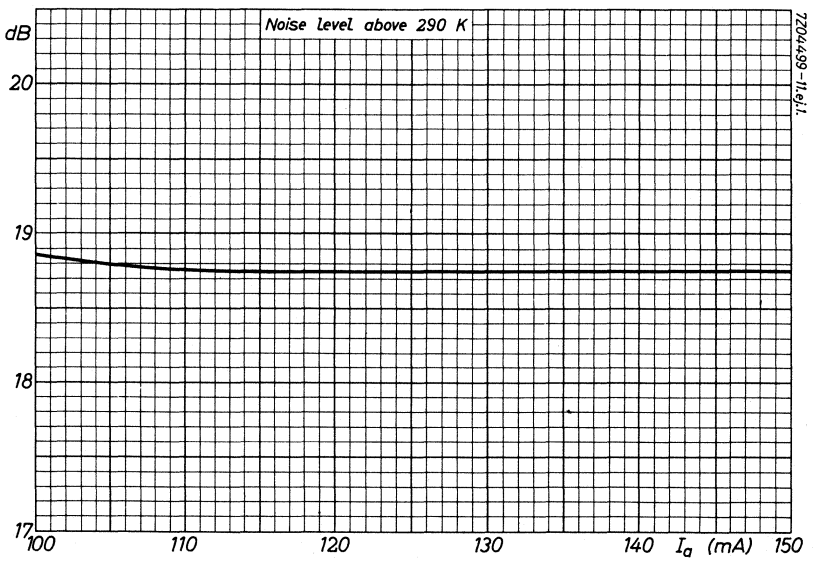

Fig. 3.

## NOISE DIODE

Rare gas-filled noise diode for use in waveguide systems in the 10 cm waveband.

## QUICK REFERENCE DATA

Noise level above 290 K	F		17,58 dB
Ignition voltage	$V_{ign}$	min.	6000 V
Anode current	$I_a$	max.	300 mA

HEATING: direct, parallel supply

Filament voltage	$V_f$		2 V $\pm$ 10%
Filament current	$I_f$		3,5 A
Heating time	$t_w$	min.	15 s

## TYPICAL CHARACTERISTICS

Anode voltage	$V_a$		140 V
Anode current	$I_a$		200 mA
Noise temperature	$T_F$		16 600 K $\pm$ 5%
Noise level above 290 K*	F		17,58 $\pm$ 0,2 dB
Ignition voltage	$V_{ign}$	min.	6000 V

LIMITING VALUES (Absolute maximum rating system)

Anode current	$I_a$	max.	300 mA
		min.	100 mA
Ambient temperature	$t_{amb}$		-55 to +75 °C

## NOTES

It is recommended that the noise diode and the microwave part of the mount are not touching (minimum diameter of pipe 17 mm).

The VSWR in the test mount with the noise diode in operation should not be more than 1,1.

\* Change in noise level over 200 hours of operation is negligible.

MECHANICAL DATA

Dimensions in mm

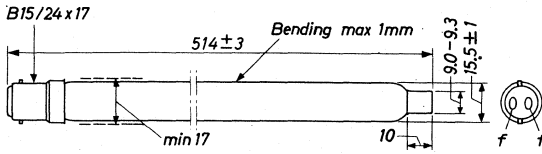

Fig. 1.

MOUNTING POSITION: Cathode at receiver side

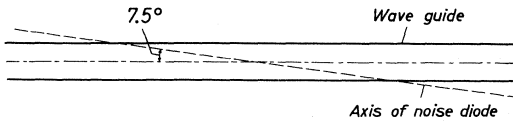

Fig. 2.



Fig. 3.



## HIGH-VACUUM, HIGH-VOLTAGE DIODE

Half-wave vacuum rectifier diode for high-voltage rectifying and surge limiting purposes.

### QUICK REFERENCE DATA

Tube voltage drop at $I_a = 100$ mA	$V_a$	200 V
Peak current at $V_{ap} = 10$ kV	$I_{ap}$	> 2 A
Maximum permissible peak inverse voltage	$V_a$ inv p	max. 40 kV
Maximum permissible rectified current	$I_a$	max. 100 mA

### APPLICATION

In radar equipment for protection of the modulator circuit and the magnetron against excessive voltages, as high-voltage rectifier, charging diode, etc. and in dust precipitation equipment.

**HEATING:** direct; thoriated tungsten filament

Filament voltage	$V_f$	5 V $\pm$ 5%
Filament current	$I_f$	min. 6 A $\pm$ 0,5 A
Waiting time	$t_w$	min. 5 s

### CAPACITANCE

Anode to filament	$C_{af}$	1,4 pF
-------------------	----------	--------

### TYPICAL CHARACTERISTICS

Tube voltage drop at $I_a = 100$ mA	$V_a$	200 V
-------------------------------------	-------	-------

**OPERATING CHARACTERISTICS** as surge limiter

Heater voltage	$V_f$	5,5 V
Peak forward anode voltage	$V_{ap}$	10 kV
Peak anode current	$I_{ap}$	> 2 A

**MECHANICAL DATA**

Dimensions in mm

Net mass: 90 g  
 Base: Medium 4p. with bayonet  
 Cap: Medium

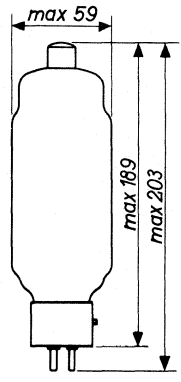
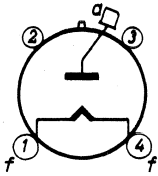

Fig. 1.

Mounting position: vertical with base down

**ACCESSORIES**

Anode clip 40619

At voltages above 2 kV the socket must be insulated from the chassis.

**LIMITING VALUES as surge limiter (Absolute maximum rating system)**

Filament voltage	$V_f$	= max.	5,8 V
Peak forward anode voltage	$V_{ap}$	= max.	12,5 kV
Peak inverse anode voltage	$V_{a invp}$	= max.	40 kV
Anode dissipation	$W_a$	= max.	75 W

**LIMITING VALUES as rectifier (Absolute maximum rating system)**

Peak inverse anode voltage	$V_{a invp}$	= max.	40 kV
Peak anode current	$I_{ap}$	= max.	750 mA
Average rectified current	$I_a$	= max.	100 mA

7Z06415- hbj

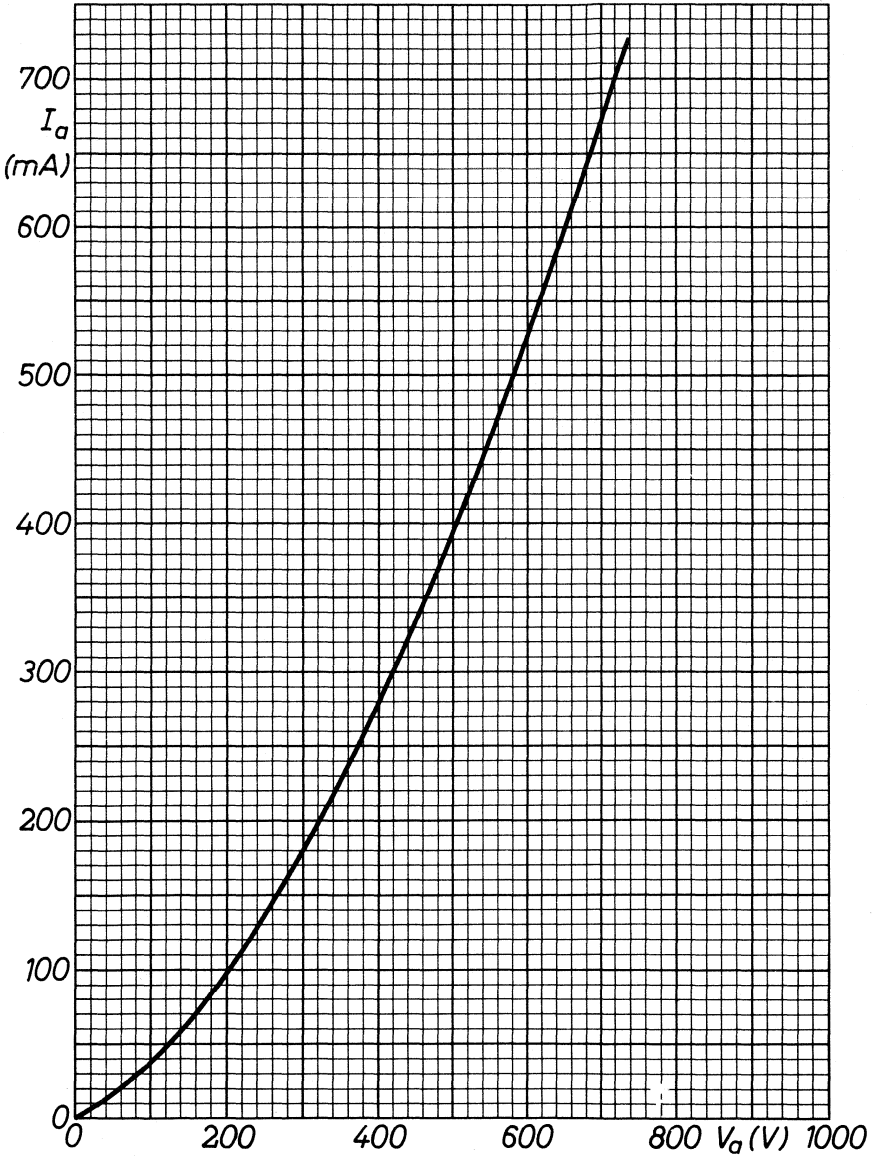





T-R SWITCHES

F







## DUAL T-R SWITCH

Broad-band gas-filled dual T-R switch covering the 8,490 to 9,580 GHz frequency band. It consists basically of two single switches forming one unit with a common flange arrangement. The 56032 is designed for operation in slot-hybrid duplexers, based on waveguide RG-52/U (WR90).

## ELECTRICAL DATA

## LIMITING VALUES (Absolute maximum rating system) AND CHARACTERISTICS

Peak power	max. 250 kW min. 3 kW
Ignitor d.c. supply voltage *	min. -600 V
Ignitor current	max. 200 $\mu$ A
Ignitor voltage drop at an ignitor current of 100 $\mu$ A	max. 300 V min. 170 V

## Low-level characteristics

Voltage standing wave ratio**	
at 8490 MHz	< 1,4
at 9580 MHz	< 1,4
at 8560 to 9490 MHz	< 1,2
Duplexer loss $\blacktriangle$	
at 8490 MHz	< 1,1 dB
at 9580 MHz	< 1,1 dB
at 8560 to 9490 MHz	< 1,0 dB

High-level characteristics  $\blacktriangle$ 

Flat leakage power	< 15 mW
Spike leakage energy	< 15 nJ
Arc loss	< 1 dB
Recovery time	< 7 $\mu$ s

\* The ignitor voltage shall be applied to each electrode via a suitable resistor giving 80 to 150  $\mu$ A ignitor current.

\*\* When measuring the v.s.w.r. the short-slot hybrids used shall have a v.s.w.r. of 1,1 max over the specified frequency band. Each hybrid shall split the power evenly to within 0,25 dB and shall have a minimum isolation of 25 dB.

$\blacktriangle$  100  $\mu$ A (d.c.) through each ignitor electrode.

**MECHANICAL DATA**

Dimensions in mm

Mounting position: any  
 Net mass: 175 g

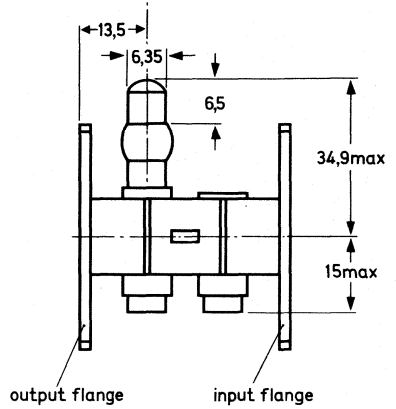
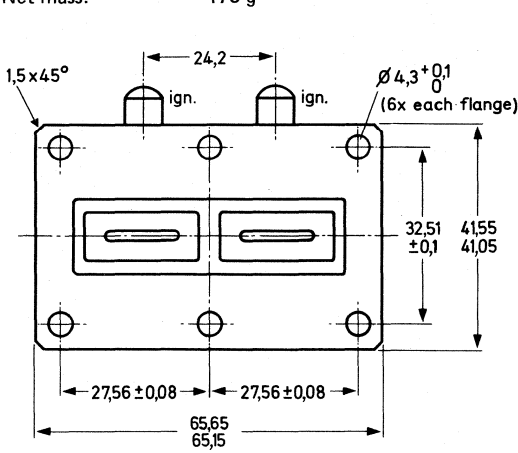
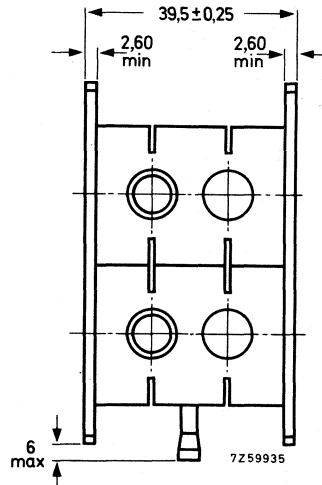

Fig. 1.



Accessories (supplied with switch)  
 Mating flange

2 gaskets, Fig. 3  
 See Fig. 2

A gasket should be placed between each flange and the mating flanges of the short-slot hybrid junctions. See Figs 2 and 3.

Pressurization

max. 350 kPa  
 min. 50 kPa

Altitude

max. 3000 in

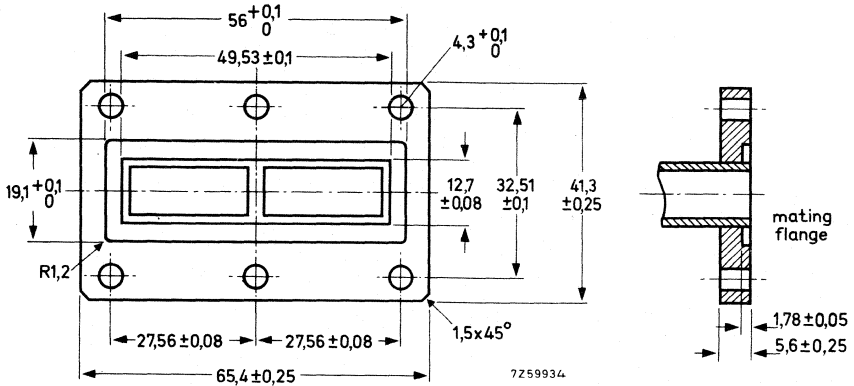

Fig. 2 Gasket assembly.

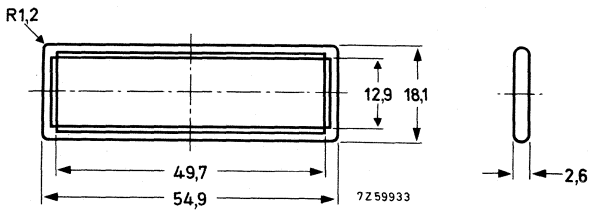

Fig. 3 Gasket.



INDEX

G







## INDEX OF TYPE NUMBERS

type no.	page	type no.	page
EA52	E3	YK1195	B61
EA53	E3	YK1196	B61
K50A	E7	YK1197	B61
K51A	E9	YK1198	B71
LB6-25	D3	YK1210	B79
YH1090	D11	YK1220	B85
YH1170	D29	YK1223	B93
YH1172	D47	YK1230	B103
YK1000	B7	YK1233	B111
YK1001	B13	YK1290	B121
YK1002	B13	YK1291	B121
YK1004	B7	YK1292	B121
YK1005	B25	YK1295	B131
YK1090	C3	YK1296	B131
YK1091	C9	YK1297	B131
YK1110	B35	YK1300	B141
YK1151	B39	7537	D65
YK1190	B51	8020	E11
YK1191	B51	55340	D73
YK1192	B51	56032	F3

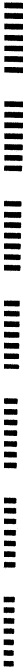

## KLYSTRONS, TWTs, MICROWAVE DIODES

- 
- A GENERAL SECTION
  - B HIGH-POWER KLYSTRONS
  - C REFLEX KLYSTRONS
  - D TRAVELLING-WAVE TUBES
  - E DIODES
  - F T-R SWITCHES
  - G INDEX



**Argentina:** PHILIPS ARGENTINA S.A., Div. Elcoma, Vedia 3892, 1430 BUENOS AIRES, Tel. 541-7141/7242/7343/7444/7545.  
**Australia:** PHILIPS INDUSTRIES HOLDINGS LTD., Elcoma Division, 67 Mars Road, LANE COVE, 2066, N.S.W., Tel. 427 08 88.  
**Austria:** ÖSTERREICHISCHE PHILIPS BAUELEMENTE Industrie G.m.b.H., Triester Str. 64, A-1101 WIEN, Tel. 62 91 11.  
**Belgium:** N.V. PHILIPS & MBLE ASSOCIATED, 9, rue du Pavillon, B-1030 BRUXELLES, Tel. (02) 242 74 00.  
**Brazil:** IBRAPE, Caixa Postal 7383, Av. Brigadeiro Faria Lima, 1735 SAO PAULO, SP, Tel. (011) 211-2600.  
**Canada:** PHILIPS ELECTRONICS LTD., Electron Devices Div., 601 Milner Ave., SCARBOROUGH, Ontario, M1B 1M8, Tel. 292-5161.  
**Chile:** PHILIPS CHILENA S.A., Av. Santa Maria 0760, SANTIAGO, Tel. 39-4001.  
**Colombia:** SADAPE S.A., P.O. Box 9805, Calle 13, No. 51 + 39, BOGOTA D.E. 1., Tel. 600 600.  
**Denmark:** MINIWATT A/S, Emdrupvej 115A, DK-2400 KØBENHAVN NV., Tel. (01) 69 16 22.  
**Finland:** OY PHILIPS AB, Elcoma Division, Kaivokatu 8, SF-00100 HELSINKI 10, Tel. 1 72 71.  
**France:** R.T.C. LA RADIOTECHNIQUE-COMPELEC, 130 Avenue Ledru Rollin, F-75540 PARIS 11, Tel. 355-44-99.  
**Germany:** VALVO, UB Bauelemente der Philips G.m.b.H., Valvo Haus, Burchardstrasse 19, D-2 HAMBURG 1, Tel. (040) 3296-0.  
**Greece:** PHILIPS S.A. HELLENIQUE, Elcoma Division, 52, Av. Syngrou, ATHENS, Tel. 9215111.  
**Hong Kong:** PHILIPS HONG KONG LTD., Elcoma Div., 15/F Philips Ind. Bldg., 24-28 Kung Yip St., KWAI CHUNG, Tel. (0)-24 51 21.  
**India:** PEICO ELECTRONICS & ELECTRICALS LTD., Elcoma Div., Ramon House, 169 Backbay Reclamation, BOMBAY 400020, Tel. 295144.  
**Indonesia:** P.T. PHILIPS-RALIN ELECTRONICS, Elcoma Div., Panim Bank Building, 2nd Fl., J.I. Jend. Sudirman, P.O. Box 223, JAKARTA, Tel. 716 1  
**Ireland:** PHILIPS ELECTRICAL (IRELAND) LTD., Newstead, Clonskeagh, DUBLIN 14, Tel. 69 3355.  
**Italy:** PHILIPS S.p.A., Sezione Elcoma, Piazza IV Novembre 3, I-20124 MILANO, Tel. 2-6752-1.  
**Japan:** NIHON PHILIPS CORP., Shuwa Shinagawa Bldg., 26-33 Takanawa 3-chome, Minato-ku, TOKYO (108), Tel. 448-5611.  
 (IC Products) SIGNETICS JAPAN LTD., 8-7 Sanbancho Chiyoda-ku, TOKYO 102, Tel. (03)230-1521.  
**Korea:** PHILIPS ELECTRONICS (KOREA) LTD., Elcoma Div., Philips House, 260-199 Itaewon-dong, Yongsan-ku, C.P.O. Box 3680, SEOUL, Tel. 794  
**Malaysia:** PHILIPS MALAYSIA SDN. BERHAD, No. 4 Persiaran Barat, Petaling Jaya, P.O.B. 2163, KUALA LUMPUR, Selangor, Tel. 77 44 11.  
**Mexico:** ELECTRONICA, S.A. de C.V., Carr. Mexico-Toluca km. 62.5, TOLUCA, Edo. de Mexico 50140, Tel. Toluca 91(72)1613-00.  
**Netherlands:** PHILIPS NEDERLAND, Marktgroep Elconco, Postbus 90050, 5600 PB EINDHOVEN, Tel. (040) 79 33 33.  
**New Zealand:** PHILIPS ELECTRICAL IND. LTD., Elcoma Division, 2 Wagener Place, St. Lukes, AUCKLAND, Tel. 894-160.  
**Norway:** NORSK A/S PHILIPS, Electronica Dept., Sandstuveien 70, OSLO 6, Tel. 68 02 00.  
**Peru:** CADESA, Av. Alfonso Ugarte 1268 , LIMA 5, Tel. 326070.  
**Philippines:** PHILIPS INDUSTRIAL DEV. INC., 2246 Pasong Tamo, P.O. Box 911, Makati Comm. Centre, MAKATI-RIZAL 3116, Tel. 86-89-51 to 59.  
**Portugal:** PHILIPS PORTUGUESA S.A.R.L., Av. Eng. Duarte Pacheco 6, LISBOA 1, Tel. 68 31 21.  
**Singapore:** PHILIPS PROJECT DEV. (Singapore) PTE LTD., Elcoma Div., Lorong 1, Toa Payoh, SINGAPORE 1231, Tel. 25 38 811.  
**South Africa:** EDAC (Pty.) Ltd., 3rd Floor Rainer House, Upper Railway Rd. & Ove St., New Doornfontein, JOHANNESBURG 2001, Tel. 614-2362/9.  
**Spain:** MINIWATT S.A., Balmes 22, BARCELONA 7, Tel. 301 63 12.  
**Sweden:** PHILIPS KOMPLEMENTER A.B., Lidingsvägen 50, S-11584 STOCKHOLM 27, Tel. 08/67 97 80.  
**Switzerland:** PHILIPS A.G., Elcoma Dept., Allmendstrasse 140-142, CH-8027 ZÜRICH, Tel. 01-488 22 11.  
**Taiwan:** PHILIPS TAIWAN LTD., 3rd Fl., San Min Building, 57-1, Chung Shan N. Rd, Section 2, P.O. Box 22978, TAIPEI, Tel. (02)-5631717.  
**Thailand:** PHILIPS ELECTRICAL CO. OF THAILAND LTD., 283 Silom Road, P.O. Box 961, BANGKOK, Tel. 233-6330-9.  
**Turkey:** TÜRK PHILIPS TICARET A.S., EMET Department, Inonu Cad. No. 78-80, ISTANBUL, Tel. 43 59 10.  
**United Kingdom:** MULLARD LTD., Mullard House, Torrington Place, LONDON WC1E 7HD, Tel. 01-580 6633.  
**United States:** (Active Devices & Materials) AMPEREX SALES CORP., Providence Pike, SLATERSVILLE, R.I. 02876, Tel. (401) 762-9000.  
 (Passive Devices) MEPCO/ELECTRA INC., Columbia Rd., MORRISTOWN, N.J. 07960, Tel. (201)539-2000.  
 (Passive Devices & Electromechanical Devices) CENTRALAB INC., 5855 N. Glen Park Rd., MILWAUKEE, WI 53201, Tel. (414)228-7380.  
 (IC Products) SIGNETICS CORPORATION, 811 East Arques Avenue, SUNNYVALE, California 94086, Tel. (408) 739-7700.  
**Uruguay:** LUZILECTRON S.A., Avda Uruguay 1287, P.O. Box 907, MONTEVIDEO, Tel. 91 43 21.  
**Venezuela:** IND. VENEZOLANAS PHILIPS S.A., Elcoma Dept., A. Ppal de los Ruices, Edif. Centro Colgate, CARACAS, Tel. 36 05 11.

**For all other countries apply to:** Philips Electronic Components and Materials Division, Corporate Relations & Projects, Building BAE3, 5600 MD EINDHOVEN, The Netherlands, Tel. +31 40 72 33 04, Telex 35000 phtc nl.

A31

© 1983 Philips Export B.V.

This information is furnished for guidance, and with no guarantees as to its accuracy or completeness; its publication conveys no licence under any patent or other right, nor does the publisher assume liability for any consequence of its use; specifications and availability of goods mentioned in it are subject to change without notice; it is not to be reproduced in any way, in whole or in part, without the written consent of the publisher.